





	IndicePag. 1 a 9 Index / index / index
	Soluciones para ángulos y cantonerasPag. 11 a 27 Corners and Edges Solutions / Des Solutions pour Angles et Coins / Lösungen für Winkel und Kanten
	Soluciones para listelosPag. 29 a 49 Listellos Solutions / Des Solutions pour Listels / Lösungen für Zierleisten
	Soluciones para peldañosPag. 51 a 80 Stair-Nosing Solutions / Des Solutions pour Nez de Marches / Lösungen für Treppenstufen
	Soluciones para transicionesPag. 83 a 98 Transition Solutions / Des Solutions pour les transitions / Lösungen für Übergänge.
	Soluciones para juntas de dilataciónPag. 99 a 103 Expansion Joint Solutions / Des Solutions pour Joints de Dilatation / Lösungen für Dehnungsverbindungen
	Soluciones para ángulos interiores (escocia)Pag. 105 a 115 Cove-Shaped Solutions / Des Solutions pour Angle Interieur / Lösungen für Innenecken
	Soluciones para LEDPag. 117 a 126 LED Solutions / Des Solutions pour LED / Lösungen für LED.
	Soluciones para vierteaguasPag. 127 a 130 Balcony profiles Solutions / Des Solutions pour Balcon profilés / Lösungen für Regenrinnen
	Soluciones zócalosPag. 132 Skirting Solutions / Des Solutions pour Plinthes / Lösungen für Sockel
	Soluciones para bloques de vidrioPag. 133 Glass block solutions / Des Solutions pour Parois en verre / Lösungen für Glassteinwänden
	Soluciones para desagües e impermeabilizaciónPag. 135 a 146 Drain and waterproofing solutions / Des Solutions pour Evacuation, imperméabilisation / Lösungen für Wasserabfluss, wasserdichter folie
	Soluciones autonivelantes y separadoresPag. 147 a 151 Self-levelling and Cross-Pieces Solutions / Des Solutions pour Autonivelant, Croix Pièces / Lösungen für Selbstnivellierungslösung, Kreuzteile
	Soluciones herramientasPag. 153 a 162 Tool solutions / Des Solutions pour outils / Lösungen für werkzeuge
	Soluciones mosaico autoadhesivoPag. 164 a 165 Self-adhesive mosaic / Mosaïque auto-adhesive / Selbstklebendes mosaik
	Gama colores y Material promocionalPag. 166 a 171 Decoration range, Display and Folders / Gamme finition, Systèmes de Présentoirs / Werbematerial
	Información técnicaPag. 172 a 175 Technique information

Soluciones
para Angulos
y Cantoneras
Corners and
Edges Solutions

11
27



Soluciones
para Listelos
Listellos Solutions

26
49



Soluciones
para Peldaños
Stair-Nosing
Solutions

51
80

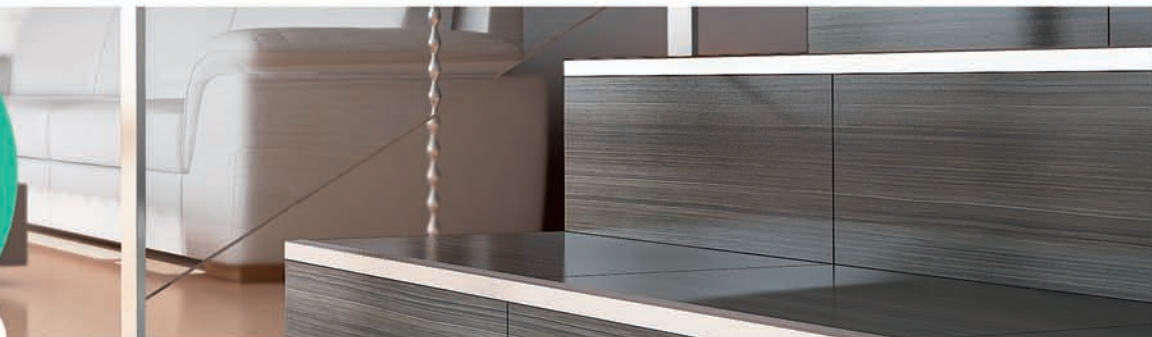

Soluciones
para
Transiciones
Transition
Solutions

83
98



Soluciones
para Juntas
de Dilatación
Expansion
Joint Solutions

99
103



Soluciones
para Angulos
Interiores,
Escocias
Cove-Shaped
Solutions

105
115

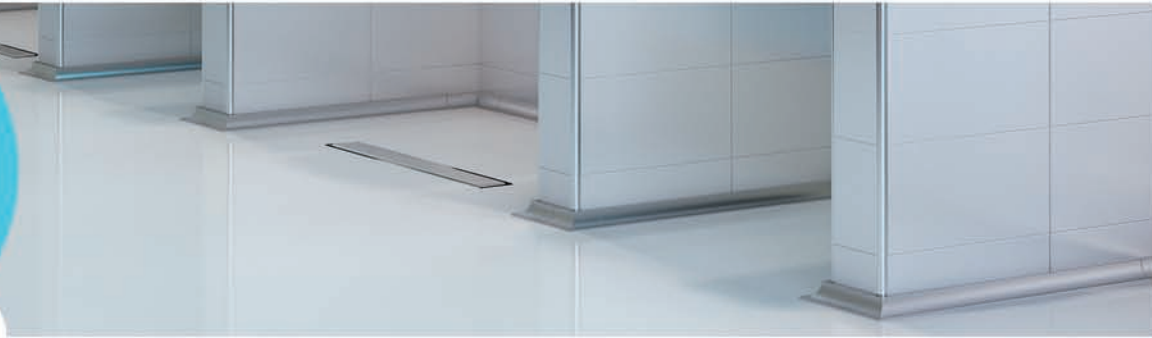

Soluciones
para LED
LED Solutions

117
126



Soluciones
para
Verteaguas
Balcony profiles
Solutions

127
130

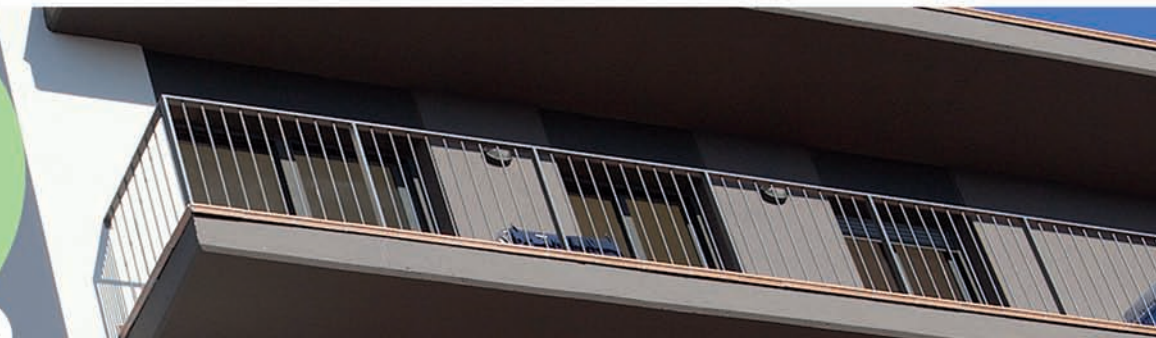

Soluciones
Diversas
Diversity Solutions

132



Soluciones
para Desagues
Drain Solutions

135
146



Separadores,
Autonivelante
Cross-Pieces,
Self-levelling

147
151

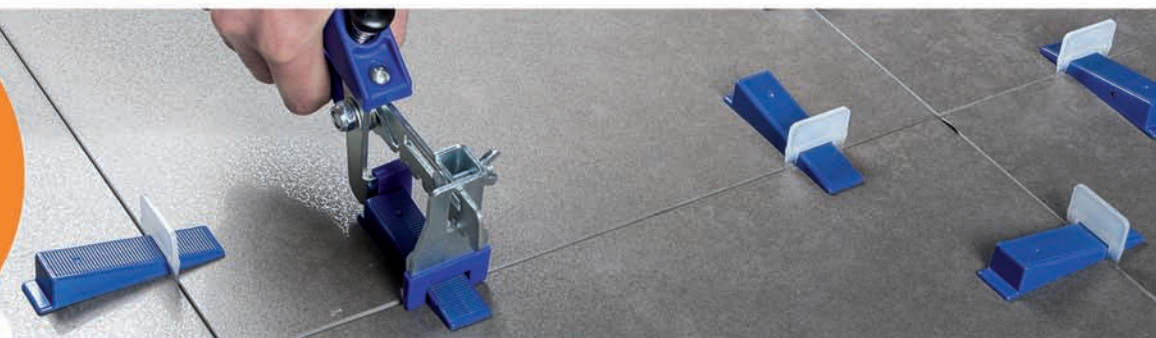

Soluciones
Herramientas
Tool Solutions

153
163





Soluciones para ángulos y cantoneras

Corners and Edges Solutions / Des Solutions pour Angles et Coins / Lösungen für Winkel und Kanten



Pag.12
EUROCANTO-171
EUROCORNER-171



Pag.13
EUROCANTO-188
EUROCORNER-188



Pag.14
EUROCANTO-171R
EUROCORNER-171R



Pag.15
EUROCANTO-171A/L
EUROCORNER-171A/L



Pag.16
EUROCANTO-171S
EUROCORNER-171S



Pag.17
EUROCANTO-197
EUROCORNER-197



Pag.18-19
EUROCANTO-183 / 183R
EUROCORNER-183 / 183R



Pag.20
EUROCANTO-183A / L
EUROCORNER-183A / L

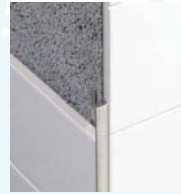

Pag.21
EUROCANTO-183S
EUROCORNER-183S



Pag.22
EUROCANTO-145A
EUROCORNER-145A



Pag.23
EUROCANTO-150A
EUROCORNER-150A

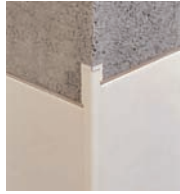

Pag.24
EUROCANTO-200A
EUROCORNER-200A



Pag.25
EUROCANTO-239S
EUROCORNER-239S



Pag.26
EUROCANTO-193 / A / S
EUROCORNER-193 / A / S



Pag.27
EUROYESO-169
EUROPLASTER-169



Soluciones para listelos

Listellos Solutions / Des Solutions pour Listels / Lösungen für Zierleisten



Pag.30
EUROMULTIUSOS-212 / R
EUROMULTIPURPOSE-212 / R



Pag.31
212R TEXTURA
212R TEXTURA

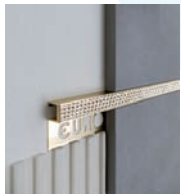

Pag.33
212A CRYSTAL
212A CRYSTAL



Pag.34
EUROMULTIUSOS-212A / L
EUROMULTIPURPOSE-212A / L



Pag.35
212A NATURA
212A NATURA



Pag.37
EUROLISTELO 212L
EUROLISTELLO-212L



Pag.38
EUROMULTIUSOS-212S
EUROMULTIPURPOSE-212S



Pag.40
EUROMULTIUSOS-213A/S
EUROMULTIPURPOSE-213A/S



Pag.41
EUROMULTIUSOS-230A
EUROMULTIPURPOSE-230A



Pag.42
EUROMULTIUSOS-246A
EUROMULTIPURPOSE-246A

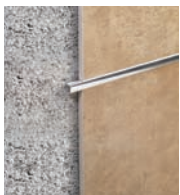

Pag.43
EUROLISTELO-219A / L
EUROLISTELLO-219A / L



Pag.43
EUROLISTELO-220A / L
EUROLISTELLO-220A / L



Pag.44
EUROLISTELO-225A
EUROLISTELLO-225A



Pag.45
EUROLISTELOS-219S
EUROLISTELLOS-219S



Pag.45
EUROLISTELOS-221/225S
EUROLISTELLOS-221/225S



Pag.46
EUROLISTELO-220S
EUROLISTELLO-220S



Pag.47
EUROLISTELO-247A
EUROLISTELLO-247A



Pag.48
EUROLISTELO-250A
EUROLISTELLO-250A



Pag.49
EUROBASE-226/227/272/286A
EUROBASE-226/227/272/286A

 **Soluciones para peldaños**
Stair-Nosing Solutions / Des Solutions pour Nez de Marches / Lösungen für Treppenstufen



Pag.52

EUROPELDAÑO-245R/254R
EUROSTEP-245R/254R



Pag.53

EUROPELDAÑO-268R
EUROSTEP-268R



Pag.54

245R TEXTURA
245R TEXTURA



Pag.55

268R TEXTURA
268R TEXTURA



Pag.56

EUROPELDAÑO-198 / 238N
EUROSTEP-198 / 238N



Pag.57

EUROPELDAÑO-199N
EUROSTEP-199N



Pag.58

EUROPELDAÑO-237N
EUROSTEP-237N



Pag.59

EUROPELDAÑO-209A / S
EUROSTEP-209A / S



Pag.60

EUROPELDAÑO-208A
EUROSTEP-208A



Pag.61

EUROPELDAÑO-248S
EUROSTEP-248S



Pag.62

EUROPELDAÑO-222A
EUROSTEP-222A



Pag.63

EUROPELDAÑO-251A
EUROSTEP-251A



Pag.64

EUROPELDAÑO-243A
EUROSTEP-243A

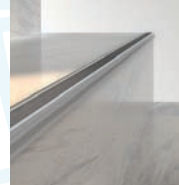

Pag.65

EUROPELDAÑO-299A
EUROSTEP-299A



Pag.66

EUROPELDAÑO-279S
EUROSTEP-279S



Pag.67

EUROPELDAÑO-229A
EUROSTEP-229A



Pag.68

EUROPELDAÑO-215A
EUROSTEP-215A



Pag.69

EUROPELDAÑO-252A
EUROSTEP-252A



Pag.70

EUROPELDAÑO-215S
EUROSTEP-215S

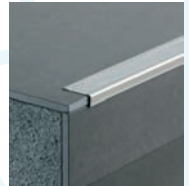

Pag.71

EUROPELDAÑO-260S
EUROSTEP-260S



Pag.72

EUROPELDAÑO-231A
EUROSTEP-231A



Pag.73

EUROPELDAÑO-298A
EUROSTEP-298A

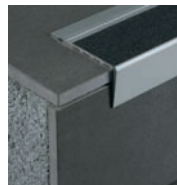

Pag.74

EUROPELDAÑO-236A
EUROSTEP-236A



Pag.75

EUROPELDAÑO-253A
EUROSTEP-253A



Pag.76

EUROPELDAÑO-264A
EUROSTEP-264A



Pag.77

EUROPELDAÑO-295A
EUROSTEP-295A

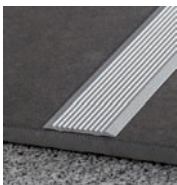

Pag.78

EUROPLETINA-296A
EUROPLATEN-296A

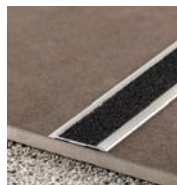

Pag.79

EUROPLETINA-297A
EUROPLATEN-297A



Pag.80

EUROCINTA ANTIDESLIZANTE CA
ANTI-SLIP EUROTAPE CA



Soluciones para transiciones

Transition Solutions / Des Solutions pour les transitions / Lösungen für Übergänge



Pag.84
EUROTRANSICION-201A
EUROTRANSICION-201A

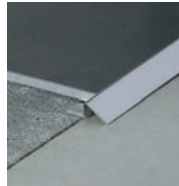

Pag.85
EUROTRANSICION-201S
EUROTRANSICION-201S



Pag.86
EUROTRANSICION-240A
EUROTRANSICION-240A

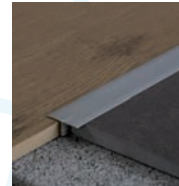

Pag.87
EUROTRANSICION-232A
EUROTRANSICION-232A



Pag.88
EUROTRANSICION-232S
EUROTRANSICION-232S



Pag.89
EUROTRANSICION-216A / 234A
EUROTRANSICION-216A / 234A



Pag.90
EUROTRANSICION-262S
EUROTRANSICION-262S



Pag.91
EUROTRANSICION-218A
EUROTRANSICION-218A



Pag.92
EUROTRANSICION-292A
EUROTRANSICION-292A

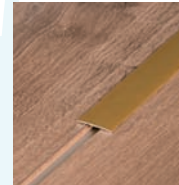

Pag.93
EUROTRANSICION-290A
EUROTRANSICION-290A



Pag.94
EUROTRANSICION-217A
EUROTRANSICION-217A



Pag.95
EUROTRANSICION-261S
EUROTRANSICION-261S



Pag.96
EUROTRANSICION-235A / 275A
EUROTRANSICION-235A / 275A



Pag.97
EUROTRANSICION-274A/L
EUROTRANSICION-274A/L



Pag.98
EUROTRANSICION-268A
EUROTRANSICION-268A



Pag.98
EUROTRANSICION-/269A
EUROTRANSICION-/269A



Soluciones para juntas de dilatacion

Expansion Joint Solutions / Des Solutions pour Joints de Dilatation / Lösungen für Dehnungsverbindungen



Pag.100
EUROJUNTA-185
EUROJOINT-185



Pag.101
EUROJUNTA-214A
EUROJOINT-214A



Pag.102
EUROJUNTA-223A / S
EUROJOINT-223 A / S



Pag.103
EUROJUNTA-186
EUROJOINT-186



Soluciones para ángulos interiores (escocias)

Cove-Shaped Solutions / Des Solutions pour Angle Interieur / Lösungen für Inneneckenungen



Pag.106
EUROESCOCIA-191
EUROCOVE-191



Pag.107
EUROESCOCIA-191A
EUROCOVE-191A



Pag.108
EUROESCOCIA-210
EUROCOVE-210



Pag.109
EUROESCOCIA-210A
EUROCOVE-210A



Pag.110
EUROESCOCIA-210S
EUROCOVE-210S



Pag.111
EUROESCOCIA-211
EUROCOVE-211



Pag.112
EUROESCOCIA-211A
EUROCOVE-211A



Pag.113
EUROESCOCIA-211S
EUROCOVE-211S

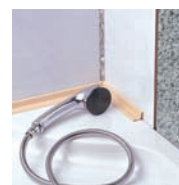

Pag.114/115
EUROBAÑERA-114 / 154
EUROBATH-114 / 154

Soluciones para LED, vierteaguas, zócalos, desagues, bloques de vidrio, separadores y autonivelante
ED Solutions, Balcony profiles, Skirting, Drains, Glass block, Crosspieces and Self-Levelling Solutions



Pag.118
EUROCANTO LED-300A
EUROCORNER LED-300A



New colours

Pag.119
EUROCANTO LED-301A
EUROCORNER LED-301A



Pag.120
EUROLISTELO LED-302A
EUROLISTELLO LED-302A



New

Pag.121
EUROLISTELO LED-303A
EUROLISTELLO LED-303A



Pag.122
EUROLISTELO LED-305A
EUROLISTELLO LED-305A



New

Pag.123
EUROLISTELO LED-306A
EUROLISTELLO LED-306A



Pag.124
EUROLISTELO LED-310A
EUROLISTELLO LED-310A



Pag.125
EUROZOCALO LED-320A
EUROSKIRTING LED-320A



Pag.126
COMPLEMENTOS LED
COMPLEMENTS LED

Soluciones para vierteaguas
Balcony profiles



Pag.128
EUROVIERTTEAGUAS-241/278/282A
EUROBALCONY-241/278/282A



Pag.129
EUROVIERTTEAGUAS-242A
EUROBALCONY-242A

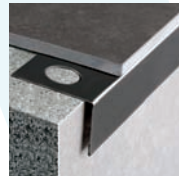

Pag.130
EUROVIERTTEAGUAS-280A/S
EUROBALCONY-280A/S

Soluciones para zócalos y B. vidrio
Skirting and Glass block Solutions



Pag.132
EUROZOCALO-206A
EUROSKIRTING-206A



Pag.133
EUROCANTO-265A/S-277A
EUROCORNER-265A/S-277A

Soluciones para desagues
Drains Solutions



Pag.136/137
EURODESAGUE-1701/2/3S
EURODRAIN-1701/1/3S



Pag.138
EURODESAGUE-SLIM DRAIN
EURODRAIN-SLIM DRAIN



Pag.139
EURODESAGUE-1601S
EURODRAIN-1601S



New colours

Pag.140/141
KIT PREMIUM
KIT PREMIUM



Pag.142
KIT CLASSIC
KIT CLASSIC



Pag.143
KIT CERAMIC
KIT CERAMIC



New colours

Pag.145
EUROESTANTE-EST90
EURO SHELF-EST90



New

Pag.146
WATERPROOF .5
WATERPROOF .5

Soluciones para separadores y autonivelante
Crosspieces and Self-Levelling Solutions



New

Pag.148/149
EUROLEVELLING WEDGE
EUROLEVELLING WEDGE



Pag.150
EUROLEVELLING
EUROLEVELLING



Pag.151
EUROCRUCETAS C-T-CU
EURO CROSSPIECES C-T-CU



Soluciones herramientas

Tool Solutions / Solutions d'outils / Lösungswerkzeuge



Pag.154

EUROPALETA-1000
ROUND TROWEL-100



Pag.154

EUROPALETA-1020
ROUND TROWEL-1020



Pag.154

EUROPALETA-1010
SQUARE TROWEL-1010



Pag.155

EUROLLANA-1106
NOTCH TROWEL-1106



Pag.155

EUROLLANA-1160
NOTCH TROWEL-1160



Pag.155

EUROLLANA-1100
TROWEL-1100



Pag.155

EUROLLANA-1150
TROWEL-1150



Pag.156

EUROLLANA-1180/81
SCRAPING TROWEL-1180/81



Pag.156

EUROLLANA-1200
GROUT FLOAT-1200



Pag.156

EUROLLANA-1220
GROUT FLOAT-1220



Pag.157

EUROESPATULA-1250
SPREADER-1250



Pag.157

EUROREGLETA-1260
SPREADER-1260



Pag.157

EUORMANGO-1270
HANDLE-1270



Pag.158

EUROLLANA CLEAN-1400/1/2/3
GROUT FLOAT-1400/1/2/3



Pag.158

EUROCUBO-1460
CLEANING BUCKET-1460



Pag.158

EURORASCADOR-1450
GROUT SCRAPER-1450



Pag.159

EUROESPATULA-1440/1441
PUTTY KNIFE-1440/1441



Pag.159

EURONIVEL-1700/1705
LEVEL-1700/1705



Pag.159

EURMACETA-1510/1520
STEEL Mallet-1510/1520



Pag.159

EUROMAZA-1500/1501
RUBBER Mallet-1500/1501



Pag.160

EUROVENTOSA-1550/2
SUCTION CUP-1550/2



Pag.160

EURODILLERA-1600
KNEE GUARD-1600



Pag.160

EUROVARILLA-1800/1801
MIXER PADDLE-1800/1801



Pag.161

EUROBOCA-1950
DIAMOND DRILL-1950



Pag.161

EUROCORONA-1900
DIAMOND CROW-1900



Pag.162

EURODISCO TURBO-1980
TURBO DIAMOND BLADE-1980



Pag.162

EURODISCO CYCLON-1990
CYCLONE DIAMOND BLADE-1990



Soluciones para mosaico adhesivo

Self-adhesive mosaic Solutions



Pag.164-165

EUROMOSAICO
EUROMOSAIC

INDICE ALFABETICO

ALPHABETICAL INDEX

Ref.	Pág.	Ref.	Pág.	Ref.	Pág.	Ref.	Pág.
114	114	234A	89	1440	159	EST90	145
145A	22	235A	96	1441	159	EXPOSITORES	171
150A	23	236A	74	1450	158	F-206A	132
154	115	237N	58	1451	158	F-208A	60
169	27	238N	56	1460	158	F-209A	59
171	12	239S	25	1500 / 1	159	F-209S	59
171A	15	240A	86	1510	159	F-210A	109
171D	12	241A	128	1520	159	F-211A	112
171L	15	242A	129	1550	160	F-248S	61
171R	14	243A	64	1552	160	F-299A	65
171S	16	245R	52	1600	160	F-300A	118
183	18	245R TEXTURA	54	1700	159	F-301A	119
183A	20	246A	42	1705	159	F-302A	120
183L	20	247A	47	1800	160	F-303A	121
183R	19	248S	61	1801	160	F-305A	122
183S	21	250A	48	1900	161	F-306A	123
185	100	251A	63	1950	161	F-310A	124
186	103	252A	69	1980	162	F-320A	125
188	13	253A	75	1990	162	G-WATERPROOF.5	146
191	106	254R	52	1601S	139	GAMA ALUMINIO	168
191A	107	260S	71	1701S	136 / 137	GAMA INOX	167
193A	26	261S	95	1702S	136	GAMA LATÓN	168
193S	26	262S	90	1703S	136 / 137	GAMA PVC	166
197N	17	264A	76	BRIDA	148 / 149	GAMA RUSTIC	166 / 167
198N	56	265A	133	C1	151	I-145A	22
199N	57	265S	133	C2	151	I-171A	15
200A	24	268A	98	C2+	151	I-171S	16
201A	84	268R	53	C3	151	I-191A	107
201S	85	268R TEXTURA	55	C3+	151	I-206A	132
206A	132	269A	98	C4	151	I-210	108
208A	60	272A	49	C5	151	I-210A	109
209A	59	274A	97	C5+	151	I-210S	110
209S	59	274L	97	C6	151	I-211	111
210	108	275A	96	C8	151	I-211A	112
210A	109	277A	133	C10	151	I-211S	113
210S	110	278A	128	C-2PIN	126	I-241A	128
211	111	279S	66	C-4PIN	126	I-242A	129
211A	112	280A	130	CA	80	I-278A	128
211S	113	280S	130	CONTROLLED	126	I-282A	128
212	30	282A	128	CU	151	I-320A	125
212A	34 / 35 / 36	286A	49	CUÑA	148 / 149	I-WATERPROOF.5	146
212A-CRYSTAL	33	290A	93	D-WATERPROOF.5	146	I3W-210A	109
212L	37	292A	92	E90/WEDGE	148 / 149	I3W-210S	110
212R	30	295A	77	E-145A	22	I3W-211A	112
212R TEXTURA	31	296A	78	E-171A	15	I3W-211S	113
212S	38	297A	79	E-171S	16	INF. TECNICA	172 / 173 / 174 / 175
213A	40	298A	73	E-191A	107	J-206A	132
213S	40	299A	65	E-206A	132	J-280A	130
214A	101	300A	118	E-209S	59	J-280S	130
215A	68	301A	119	E-210	108	KIT PREMIUM	140 / 141
215S	70	302A	120	E-210A	109	KIT CLASSIC	142
216A	89	303A	121	E-210S	110	KIT CERAMIC	143
217A	94	305A	122	E-211	111	LED-IP65	126
218A	91	306A	123	E-211A	112	LEVEL BASE	150
219A	43	310A	124	E-211S	113	LEVEL CAP	150
219L	43	320A	125	E-212A	34	LEVEL GUN	150
219S	45	1000	154	E-212S	38	LEVEL KIT	150
220A	43	1010	154	E-213A	40	MATERIAL PUBLICITARIO	169 - 171
220L	43	1020	154	E-241A	128	MOAICO	164 / 165
220S	46	1106/8/10/12	155	E-242A	129	PLATFORM/WEDGE	148 / 149
221S	45	1100	155	E-248S	61	PROTECT/WEDGE	148 / 149
222A	62	1160/62	155	E-278A	128	ROLLER/WEDGE	149
223A	102	1150	155	E-280A	130	SLIM DRAIN	138
223S	102	1180	156	E-280S	130	T10	151
225A	44	1181	156	E-282A	128	T4	151
225S	45	1200	156	E-301A	119	T5	151
226A	49	1220	156	E-302A	120	T6	151
226S	49	1250	157	E-305A	122	T8	151
227A	49	1260	157	E-306A	123	TENAZA	149
227S	49	1265	157	E-320A	125	TR-IP67	126
229A	67	1270	157	E-WATERPROOF.5	146	WATERPROOF.5	146
230A	41	1400	158	ECO171A	15	WEDGE KIT	148 / 149
231A	72	1401	158	ECO212A	34	WPD,5/30	146
232A	87	1402	158	ECO212S	38		
232S	88	1403	158	ES90-301A	119		





Los perfiles para ángulos y cantonerías están desarrollados para proteger los cantos del azulejo, o cualquier otro material, de los deterioros debidos a esfuerzos mecánicos. Así mismo se pueden utilizar con este mismo fin nuestra gama de EUROMULTIUSOS, ubicada en el apartado Soluciones para listellos. Nuestra amplia gama de perfiles ofrece una gran capacidad de combinación, tanto en interiores como exteriores, así como en ambientes modernos o rústicos, pudiendo obtener un remate perfecto de los cantos gracias a las piezas especiales disponibles de cada referencia.

Our profiles for corners and edges were developed to protect the tiles' edges or any other building material from damage due to mechanical stress. Our range EUROMULTIUSOS can also be used for this purpose, and can be found in the section called Solutions for listellos. Our extensive variety of profiles gives you great combination possibilities, because they can be used both inside and outside of buildings, and in modern or rustic style rooms. Our special pieces for corners which are available for all products provide the perfect finishing.

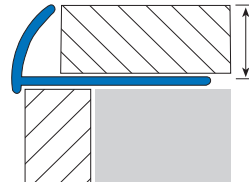
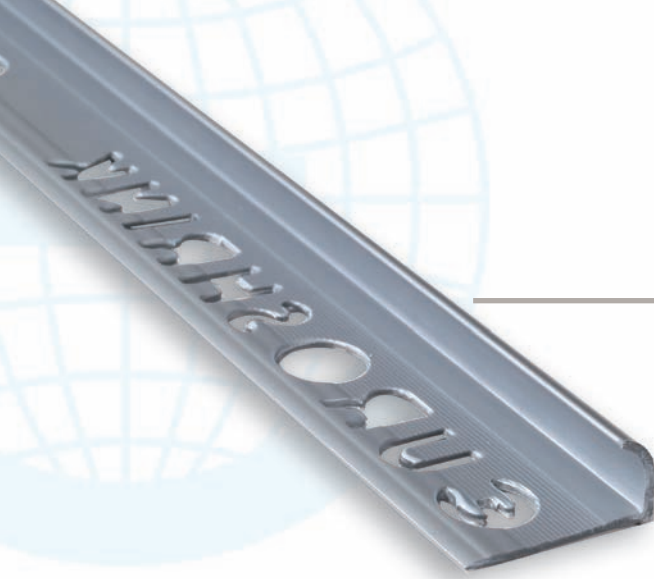

ES EUROCORNER-171, perfil destinado a esquinas exteriores en revestimientos cerámicos, su principal función es proteger los cantos del azulejo de los deterioros debidos a esfuerzos mecánicos. Fabricado en PVC de primera calidad.

EN EUROCORNER-171, profile for external corners in tilings, its main function is to protect ceramic tile edging from the damage of mechanical stress. Made with high-quality PVC.

Longitud 2,55 m. Embalaje: 150 u/caja.
Length 8,36 ft. Packing: 150 u/box.

Precio/Price: € /perfil

Referencia Reference	Colores Colours	h: 6 mm 1/4"	h: 8,5 mm 5/16"	h: 10 mm 3/8"	h: 12 mm 1/2"
171-BL	Blanco (BL)	1,77	1,86	2,04	2,19
171-CR	Crema (CR)	1,90	1,99	2,19	2,34
171-BE	Beige (BE)		1,99	2,19	2,34
171-MA	Marron (MA)			2,19	
171-GC	Gris claro (GC)	1,90	1,99	2,19	2,34
171-GR	Gris (GR)		1,99	2,19	2,34
171-NE	Negro (NE)		1,99	2,19	2,34
*171D-MBL	Marmol Blanco (MBL)		2,95	2,98	3,15
*171D-MCF	Marmol CF (MCF)		2,95	2,98	3,15
*171D-MCD	Marmol CD (MCD)		2,95	2,98	3,15
*171D-MCB	Marmol CB (MCB)		2,95	2,98	3,15
*171D-MMA	Marmol marron (MMA)		2,95	2,98	3,15
*171D-RO	Roble (RO)		2,95	2,98	3,15
*171D-NO	Nogal (NO)		2,95	2,98	3,15

*171D PVC Decorados, pedido mínimo 1200 piezas por color / Minimum quantity 1200 pieces per colour.
Gama de color / Colour range Pag.166



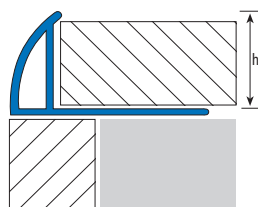

ES EUROCANTO-188, perfil destinado a esquinas exteriores en revestimientos cerámicos, su principal función es proteger los cantos del azulejo de los deterioros debidos a esfuerzos mecánicos. Fabricado en PVC de primera calidad.

EN EUROCORNER-188, profile for external corners in tilings, its main function is to protect ceramic tile edging from the damage of mechanical stress. Made with high-quality PVC.



Longitud 2,55 m. Embalaje: 150 u/caja.
Length 8,36 ft. Packing: 150 u/box.

Precio/Price: € /perfil

Referencia Reference	Colores Colours	h: 6 mm 1/4"	h: 8 mm 5/16"	h: 10 mm 3/8"
188-BL	Blanco (BL)	2,46	2,53	2,56
188-CR	Crema (CR)			2,56
188-GC	Gris claro (GC)			2,56

Gama de color / Colour range Pag.166

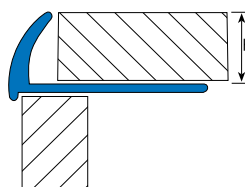

ES UROCANTO-171R, perfil rústico destinado a esquinas exteriores en revestimientos cerámicos. Su principal función es proteger los cantos del azulejo de los deterioros debidos a esfuerzos mecánicos. **Fabricado con un PVC especial con fibras naturales recicladas**, gracias a las cuales ofrece un acabado rugoso que se adapta perfectamente a los revestimientos rústicos o no uniformes que se encuentran en el mercado actual. EUROSHRINK apuesta por nuevos componentes que son por supuesto 100% reciclables.

EN EUROCORNER-171R, rustic profile intended for exterior corners at ceramic tilings, their main function is to protect the tiles' edges from damages caused by mechanical stress. Thanks to the production with a special **PVC including natural recycled fibers**, it presents a rough finishing that adjusts perfectly to rustic or uniform tilings which can be found on the current market. EUROSHRINK is increasingly committed to new components that can be recycled entirely.

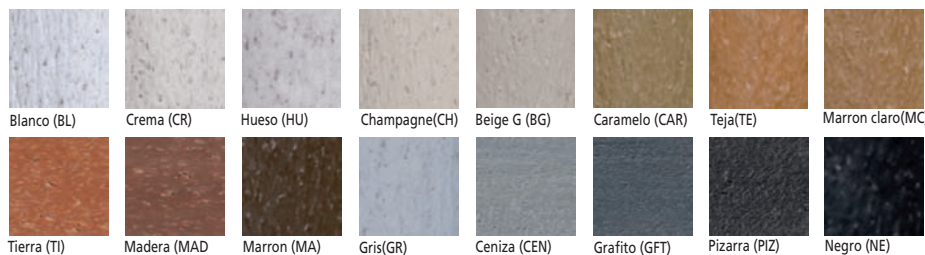

Longitud 2,55 m. Embalaje: 100 u/caja.

Lenght 8,36 ft. Packing: 100 u/box.

Precio/Price: € /perfil

Referencia Reference	Colores Colours		h: 10 mm 3/8"	h: 12 mm 1/2"
171R-BL	Blanco (BL)		6,70	7,92
171R-CR	Crema (CR)		6,70	7,92
171R-HU	Hueso (HU)		6,70	7,92
171R-CH	Champagne (CH)		6,70	7,92
171R-BG	Beige G (BG)		6,70	7,92
171R-CAR	Caramelo (CAR)		6,70	7,92
171R-TE	Teja (TE)		6,70	7,92
171R-MC	Marron claro (MC)		6,70	7,92
171R-TI	Tierra (TI)		6,70	7,92
171R-MAD	Madera (MAD)		6,70	7,92
171R-MA	Marron (MA)		6,70	7,92
171R-GR	Gris (GR)		6,70	7,92
171R-CEN	Ceniza (CEN)		6,70	7,92
171R-GFT	Grafito (GFT)		6,70	7,92
171R-PIZ	Pizarra (PIZ)		6,70	7,92
171R-NE	Negro (NE)		6,70	7,92

Gama de rústicos PVC + FN / Rustic range PVC + FN Pag. 167

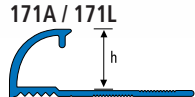
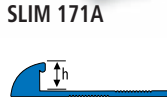
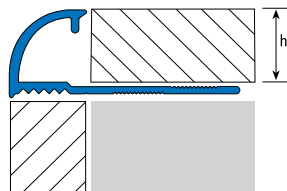
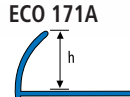
171A / 171L

SLIM 171A

ECO 171A

(A) Aluminio/Aluminium (L) Latón/Brass

ES EUROCANTO, perfil destinado a esquinas exteriores en revestimientos cerámicos. Su principal función es proteger los cantos del azulejo de los deterioros debidos a esfuerzos mecánicos. Con el EUROCANTO se obtienen acabados elegantes y perfectos que se adaptan, gracias a los diversos colores y a la amplia gama de alturas existentes, a cualquier ambiente. El EUROCANTO-171A dispone de piezas especiales para los finales de esquinas exteriores, ref. **E-171A**, y esquinas interiores, ref. **I-171A**

EN EUROCORNER, profile intended for external corners in ceramic tilings. Their main function is to protect the tiles' edges of damages caused by mechanical stress. With EUROCORNER, you obtain elegant and perfect finishings that adjust to any surroundings, thanks to the different colours and the wide range of existing heights. EUROCORNER-171A have special parts for the ends of outdoor corners, reference **E-171A**



171L Latón cromado / Chrome brass

Aluminio - Longitud 2,50 m. Embalaje: 10 u/caja.

Aluminium - Lenght: 8,2 ft. Packing: 10 u/box.

Precio/Price: € /perfil

Referencia Reference	Colores Colours	h: 3 mm 1/8"	h: 4,5 mm 3/16"	h: 6 mm 1/4"	h: 8 mm 5/16"	h: 10 mm 3/8"	h: 12 mm 1/2"	h: 15 mm 9/16"
SLIM 171A-PB	Plata brillo	11,11	11,70					
SLIM 171A-PM	Plata mate	9,22	9,73					
171A-BL	Blanco			9,68	€ 10,02	€ 11,22	€ 12,35	€ 16,05
171A-CR	Crema				€ 10,02	€ 11,22	€ 12,35	€ 16,05
171A-PB	Plata brillo			11,70	€ 10,35	€ 11,69	€ 12,89	€ 19,97
171A-PM	Plata mate				€ 9,68	€ 10,68	€ 11,69	€ 15,81
171A-PC	Plata cepillado					€ 11,69	€ 14,30	
171A-OB	Oro brillo				€ 11,49	€ 12,96	€ 14,36	
171A-OM	Oro mate				€ 9,68	€ 10,68	€ 11,69	
171A-BRM	Bronce mate					€ 11,66	€ 14,30	
171A-NM	Negro mate					€ 11,66	€ 14,30	

E-171A (esquina exterior / external corner)
Blister: 1 u.

E-171A	€			7,35	7,35	8,09	8,70
--------	---	--	--	------	------	------	------

I-171S (esquina interior / internal corner)
Blister: 1 u.

I-171A	①			9,01	9,01	9,68	10,29
--------	---	--	--	------	------	------	-------

Aluminio - Longitud 2,50 m. Embalaje: 50 u/caja. Aluminium - Lenght: 8,2 ft. Packing: 50 u/box.

ECO 171A	Plata brillo				7,68	8,01	
ECO 171A	Plata mate				7,01	7,35	
ECO 171A	Blanco				7,50	7,68	

Latón cromado - Longitud 2,50 m. Embalaje: 20 u/caja. Chrome brass - Lenght: 8,2 ft. Packing: 20 u/box.

171L-CRO	Latón cromado				95,88	110,08	
----------	---------------	--	--	--	-------	--------	--

 Con film protector / With protective tape.
 Gama de color / Colour range. Pag.168

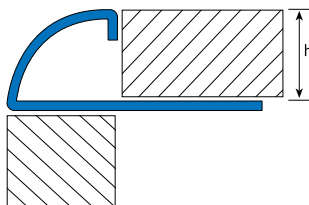

ES EUROCANTO-171S, perfil de acero inoxidable destinado a esquinas exteriores en revestimientos cerámicos. Su principal función es proteger los cantos del azulejo de los deterioros debidos a esfuerzos mecánicos. Con el EUROCANTO-171-S se obtienen acabados perfectos y elegantes que se adaptan a la demanda del mercado. Este perfil dispone de piezas especiales para los finales de esquinas exteriores, ref. E-171S, y esquinas interiores, ref. I-171S



EN EUROCORNER-171S, stainless steel profile applied for external corners in ceramic tilings. Its main purpose is to protect the tiles' edges from damages caused by mechanical stress. With EUROCORNER-171S, you obtain perfect and elegant finishings that adapt to the current demands of the market. This profile has special connecting pieces for internal corners, ref. I-171S, and external corners, ref. E-171S.



Longitud 2,50 m. Embalaje: 20 u/caja.

Lenght: 8,2 ft. Packing: 20 u/box.

Precio/Price: € /perfil

Referencia Reference	Colores Colours	h: 8 mm 5/16"	h: 10 mm 3/8"	h: 12,5 mm 1/2"	h: 15 mm 9/16"
171S-IB	Inox brillo	19,38	20,50	21,74	23,11
171S-IC	Inox cepillado	19,38	20,50	21,74	23,11
 E-171S (esquina exterior / external corner)		Blister: 1 u.			
E-171S-IB	Inox brillo	7,14	8,19	9,24	10,29
E-171S-IC	Inox cepillado	7,14	8,19	9,24	10,29
 I-171S (esquina interior / internal corner)		Blister: 1 u.			
I-171S-IB	Inox brillo	7,14	8,19	9,24	10,29
I-171S-IC	Inox cepillado	7,14	8,19	9,24	10,29

Con film protector / With protective tape. AISI - 304
Gama de color / Colour range. Pag.167

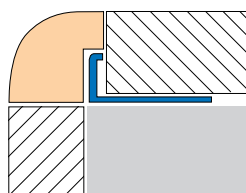
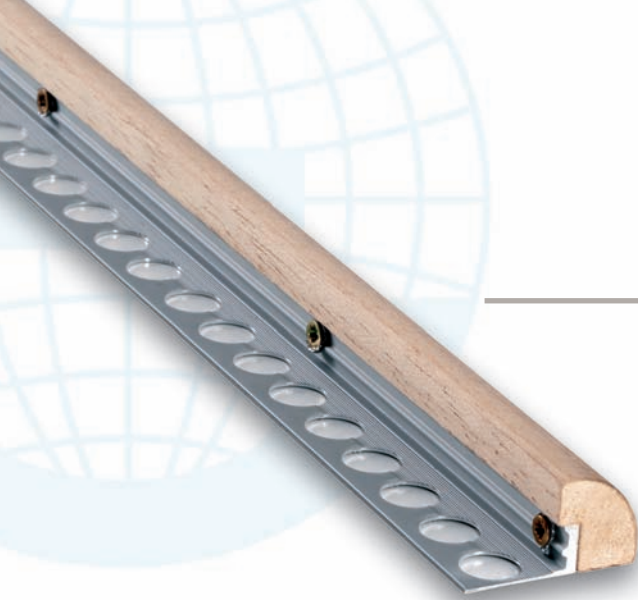

ES EUROCORNER-197N, perfil de madera y aluminio destinado a embellecer y proteger las esquinas del revestimiento, con un material noble y un acabado rústico. Su uso es apropiado tanto en esquinas exteriores como para mejorar el remate en paredes revestidas a media altura.

La parte vista del perfil se realiza en ayous, que es una madera tropical que está especialmente recomendado para combinar con revestimientos. La parte de sujeción está fabricada en aluminio, proporcionando gracias a su dureza, una gran resistencia.

EN EUROCORNER-197N, profile of wood and aluminium, which is intended to embellish and protect the corners; it displays noble material and a rustic finish. It can be used both to adorn external corners and to improve the finishing of tiled walls at medium height.

The profile of the section that can be seen is produced with AYOUS, a tropical kind of wood which is especially advisable to be combined with tilings. The section that is fixed to another surface is made of aluminium which, thanks to its hardness, is highly resistant.

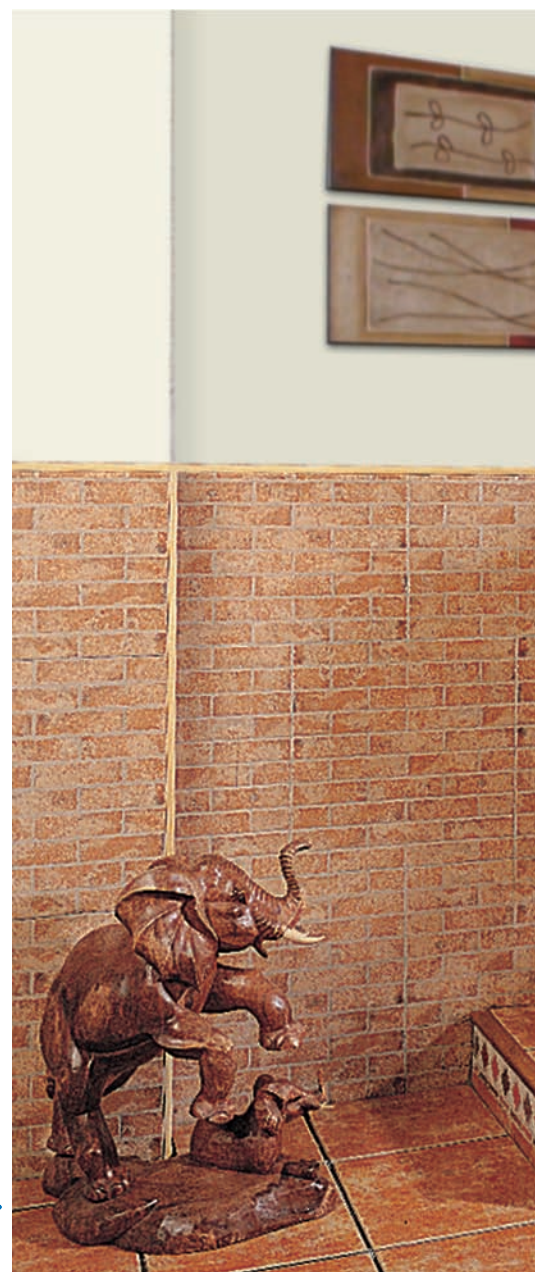

Longitud 2,50 m. Embalaje: 10 u/caja.

Lenght 8,2 ft. Packing: 10 u/box.

Precio/Price: € /perfil

Referencia Reference	Colores Colours	h: 10 mm 3/8"	h: 15 mm 9/16"
197 N	Ayous natural	29,09	31,25

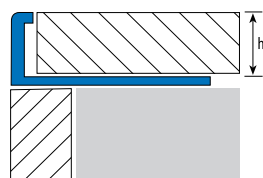
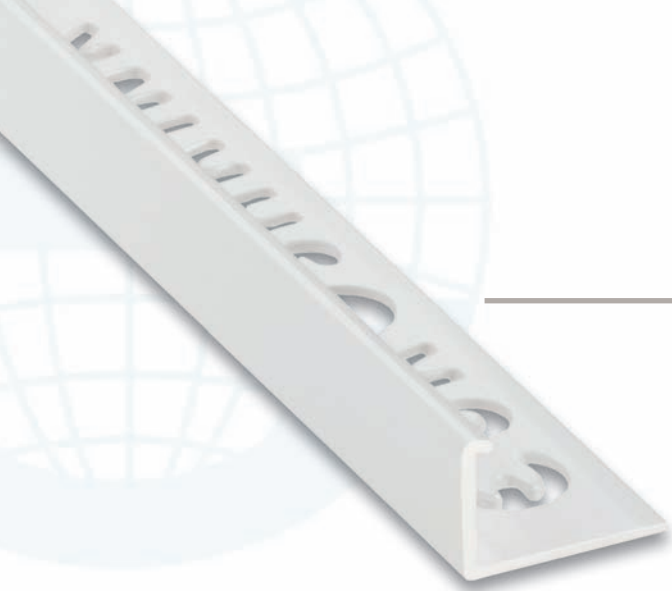

ES EUROCANTO-183, perfil destinado a esquinas exteriores en revestimientos cerámicos, su principal función es proteger los cantos del azulejo de los deterioros debidos a esfuerzos mecánicos.
Fabricado en PVC de primera calidad.

EN EUROCORNER-183, profile for external corners in tilings, its main function is to protect ceramic tile edging from the damage of mechanical stress.
Made with high-quality PVC.



Longitud 2,55 m. Embalaje: 150 u/caja.
Lenght 8,36 ft. Packing: 150 u/box.

Precio/Price: € /perfil

Referencia Reference	Colores Colours	h: 6 mm 1/4"	h: 8 mm 5/16"	h: 10 mm 3/8"	h: 12 mm 1/2"
183-BL	Blanco (BL)	1,59	1,64	1,86	1,93
183-CR	Crema (CR)		1,75	1,99	2,06
183-BE	Beige (BE)			1,99	2,06
183-MA	Marron (MA)			1,99	
183-GC	Gris claro (GC)			1,99	2,06
183-GR	Gris (GR)			1,99	
183-NE	Negro (NE)			1,99	

Gama de color / Colour range Pag.166

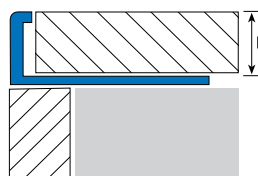
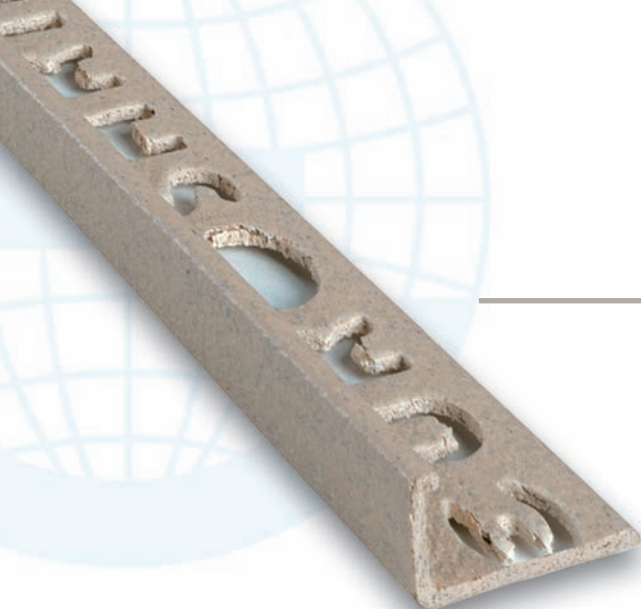

ES EUROCORNER-183R, perfil rústico de sección recta destinado a esquinas exteriores en revestimientos cerámicos. Su principal función es proteger los cantos del azulejo de los deterioros debidos a esfuerzos mecánicos. Fabricado con un **PVC especial con fibras naturales recicladas**, gracias a las cuales ofrece un acabado rugoso que se amolda perfectamente a los revestimientos rústicos o no uniformes que se encuentran en el mercado actual. EUROSHRINK apuesta por nuevos componentes que son por supuesto 100% reciclables.

EN EUROCORNER-183R, rustic profile with straight shape intended for exterior corners at ceramic tilings, their main function is to protect the tiles' edges from damages caused by mechanical stress. Thanks to the production with a **special PVC including natural recycled fibers**, it presents a rough finishing that adjusts perfectly to rustic or uniform tilings which can be found on the current market. EUROSHRINK is increasingly committed to new components that can be recycled entirely.

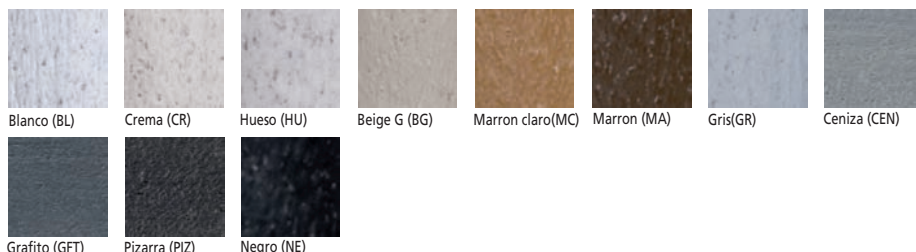

Longitud 2,55 m. Embalaje: 100 u/caja.

Lenght 8,36 ft. Packing: 100 u/box.

Precio/Price: € /perfil

Referencia Reference	Colores Colours	h: 10 mm 3/8"	h: 12 mm 1/2"
183R-BL	Blanco (BL)	6,30	7,72
183R-CR	Crema (CR)	6,30	7,72
183R-HU	Hueso (HU)	6,30	7,72
183R-BG	Beige G (BG)	6,30	7,72
183R-MC	Marron claro (MC)	6,30	7,72
183R-MA	Marron (MA)	6,30	7,72
183R-GR	Gris (GR)	6,30	7,72
183R-CEN	Ceniza (CEN)	6,30	7,72
183R-GFT	Grafito (GFT)	6,30	7,72
183R-PIZ	Pizarra (PIZ)	6,30	7,72
183R-NE	Negro (NE)	6,30	7,72

Gama de rústicos PVC + FN / Rustic range PVC + FN Pag. 167



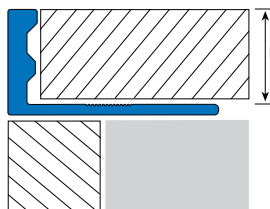
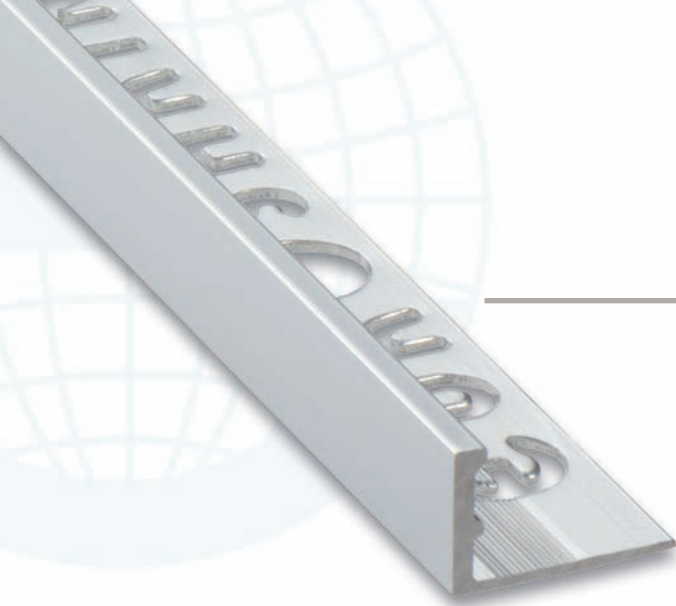

(A) Aluminio/Aluminium (L) Latón/Brass

ES EUROCANTO-183A/L, perfil destinado a esquinas exteriores en revestimientos cerámicos. Su principal función es proteger los cantos del azulejo de los deterioros debidos a esfuerzos mecánicos. No obstante puede destinarse a otros usos como por ejemplo a la enmarcación de elementos decorativos, o incluso en el suelo usando los colores anodizados mate como separador de ambientes o remate de escalones. El EUROCANTO-183A/L ofrece una gran posibilidad de combinaciones con todo tipo de azulejos debido a los colores existentes.

EN EUROCORNER 183A/L, profile intended for external aluminium corners at ceramic tilings. Their main function is to protect the tiles' edges from damages caused by mechanical stress. However, it can be applied for other purposes, such as framings of decorative elements, or even in the floor using only the matt colours, like a room dividers or step nosings. Thanks to the different existing colours, EUROCORNER-183A/L offers a great range of combinations with all kinds of tiles.

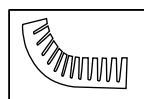

* 183A - 10/F - 12/F, Para curvar / For bending

Aluminio - Longitud 2,50 m. Embalaje: 10 u/caja.

Aluminium - Length: 8,2 ft. Packing: 10 u/box.

Precio/Price: € /perfil

Referencia Reference	Colores Colours	h: 3mm 1/8"	h: 4,5mm 3/16"	h: 8mm 5/16"	h: 10mm 3/8"	h: 12mm 1/2"	h: 15mm 9/16"	h: 20mm 3/4"
SLIM 183A-PB	Plata brillo	11,11	11,70					
SLIM 183A-PM	Plata mate	9,22	9,73					
183A-BL	Blanco			8,08	8,82	9,68	10,68	
183A-CR	Crema				9,13	9,92		
183A-PB	Plata brillo			8,55	9,35	10,28	12,08	
183A-PM	Plata mate			7,75	8,48	9,35	10,28	13,36
183A-PC	Plata Cepillado				15,38	16,48		
183A-OB	Oro brillo				10,35	11,35	12,71	
183A-OM	Oro mate				8,48	9,35	11,00	
183A-NM	Negro mate				11,44	11,76		
183A-PM/F	Plata mate				9,62	10,54		
183A-OM/F	Oro mate				11,21			
183A-ARCA	Arena camel					12,50		
183A-ARGC	Arena gris claro					12,50		
183A-ARGR	Arena gris					12,50		
183A-ARMA	Arena marron					12,50		
183A-AROX	Arena oxido					12,50		
183A-ARAN	Arena antracita					12,50		
183A-ARNE	Arena negro					12,50		

* Con film protector / With protective tape.

Latón cromado - Longitud 2,50 m. Embalaje: 20 u/caja.

Chrome brass - Length: 8,2 ft. Packing: 20 u/box.

183L-CRO			78,72	81,97	
----------	--	--	-------	-------	--

Con film protector / With protective tape. Gama de color / Colour range. Pag.168
*20mm solo disponible en 183A Plata mate / 20mm only available 183A Mat



183L Latón cromado / Chrome brass

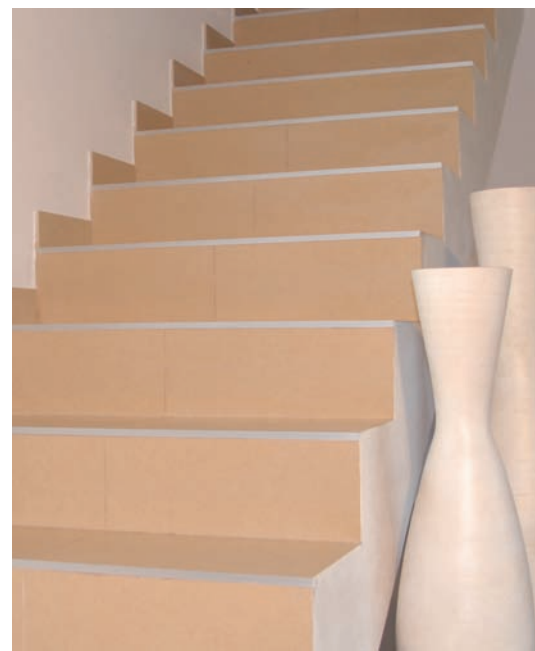



INOXIDABLE / STAINLESS STEEL

183S

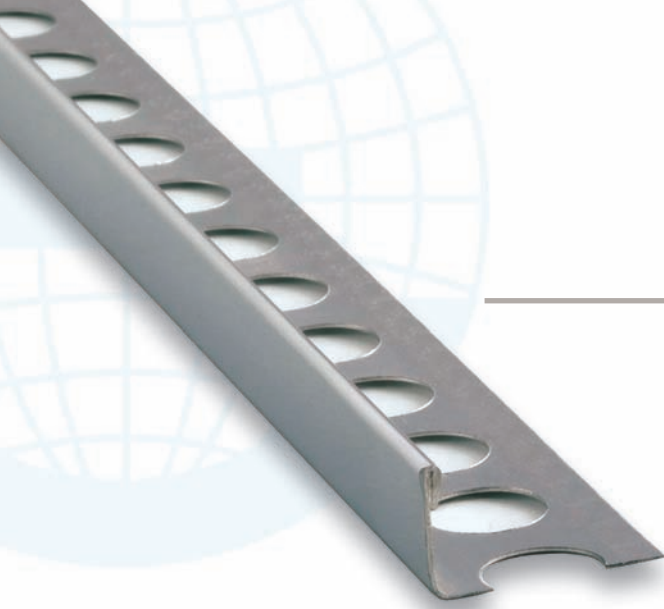

183S

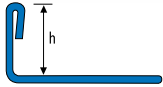

SLIM 183S

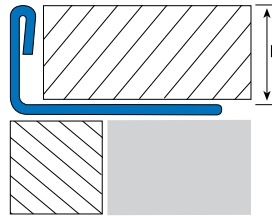
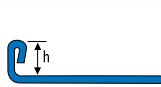

ES EUROCANTO-183S, perfil de acero inoxidable destinado a esquinas exteriores en revestimientos cerámicos. Su principal función es proteger los cantos del azulejo del deterioro debido a esfuerzos mecánicos. No obstante puede destinarse a otros usos: enmarcación de elementos decorativos, separador de ambientes, remate de escalones, etc. El EUROCANTO-183S ofrece múltiples posibilidades de combinaciones con todo tipo de cerámica o pavimento.

EN EUROCORNER-183S, stainless steel profile used for external corners in ceramic tilings. It is mainly applied to protect the tiles' edges from damages because of mechanical stress. However, it can also be employed for other purposes: framings of decorative elements, room or area dividers, finishing touches on steps, etc. EUROCORNER-183S offers various combinations with all kinds of ceramic or floorings.



Longitud 2,50 m. Embalaje: 20 u/caja.

Lenght: 8,2 ft. Packing: 20 u/box.

Precio/Price: € /perfil

Referencia Reference	Colores Colours	4,5 mm 3/16"	8 mm 5/16"	10 mm 3/8"	12 mm 1/2"	15 mm 9/16"	20 mm 3/4"	25 mm 1"	30 mm 1-3/16"
SLIM 183S-IB	Inox brillo	11,18							
SLIM 183S-IC	Inox cepillado	11,18							
183S-IB	Inox brillo		12,30	12,80	13,67	14,29	15,53	16,52	17,39
183S-IC	Inox cepillado		12,30	12,80	13,67	14,29	15,53	16,52	17,39

Con film protector / With protective tape. AISI - 304
Gama de color / Colour range. Pag.167

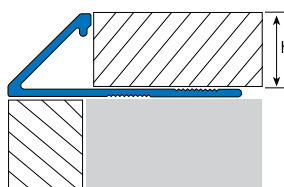
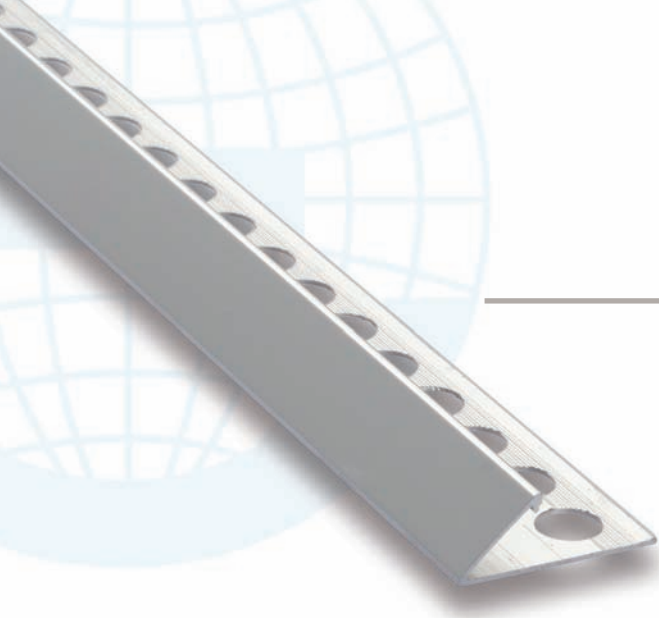

ES EUROCANTO-145A, Eurocanto de aluminio anodizado destinado a esquinas exteriores, alicatados a media altura o repisas, en revestimientos cerámicos. Su principal función es proteger los cantos del azulejo de los deterioros debidos a esfuerzos mecánicos. Con el EUROCANTO-145A, se obtiene un innovador acabado con ángulo de 45°, que rompe con los standards del momento. El acabado final es perfecto con el uso de las piezas de remate especiales: **I-145A**, esquina interior y **E-145A** esquina exterior.



EN EUROCORNER-145A, Eurocorner made of anodized aluminium and intended for external corners, waistline tiling or shelves with a ceramic tiling. Its main purpose is to protect the edges of the tiles from deterioration owing to mechanical stresses. With EUROCORNER-145A, an innovative finish is obtained with an angle of 45° which breaks away from the standards of the time. We will obtain a perfect final finish with the use of special finishing parts: **I-145A**, inner corner and **E-145A** outer corner.



Longitud 2,50 m. Embalaje: 10 u/caja.

Lenght 8,2 ft. Packing: 10 u/box.

Precio/Price: € /perfil

Referencia Reference	Colores Colours	h: 10 mm 3/8"	h: 12 mm 1/2"
145A-BL	Blanco	13,86	15,30
145A-PB	Plata Brillo	16,53	18,19
145A-PM	Plata Mate	13,75	14,98
145A-PC	Plata Cepillado	17,12	19,26
 E-145A (esquina exterior / external corner)		Blister: 1 u.	
E-145A-BL	Blanco	12,84	12,84
E-145A-PB	Plata Brillo	12,84	12,84
E-145A-PM	Plata Mate	12,84	12,84
E-145A-PC	Plata Cepillado	12,84	12,84
 I-145A (esquina interior / internal corner)		Blister: 1 u.	
I-145A-BL	Blanco	12,84	12,84
I-145A-PB	Plata Brillo	12,84	12,84
I-145A-PM	Plata Mate	12,84	12,84
I-145A-PC	Plata Cepillado	12,84	12,84

Con film protector / With protective tape.
Gama de color / Colour range. Pag.168

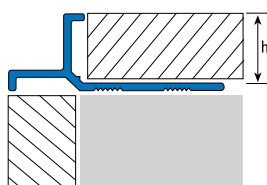
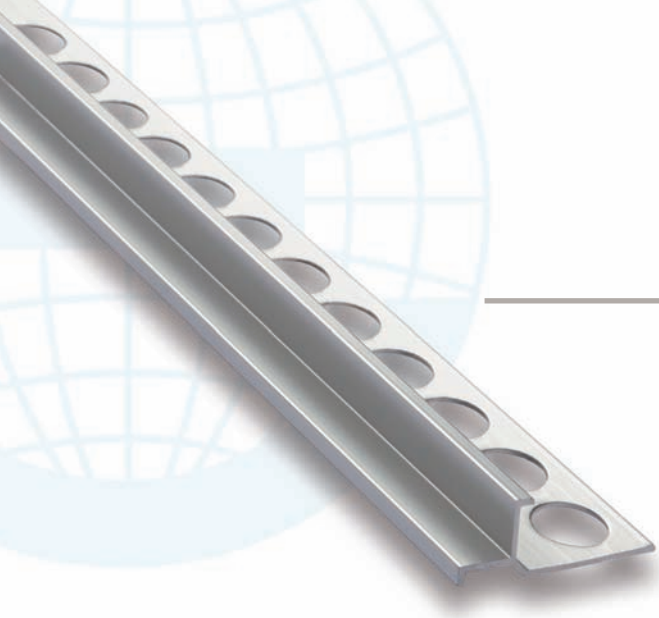

ES EUROCANTO-150A, Eurocanto de aluminio anodizado destinado a esquinas exteriores, así como al remate de ventanas y puertas, proporcionando un canto pilastra perfecto, en revestimientos cerámicos. Su principal función es proteger los cantos del azulejo de los deterioros debidos a esfuerzos mecánicos.

EN EUROCORNER-150A, Eurocorner made of anodized aluminium and intended for external corners as well as window and door finishes, providing a perfect pilaster edge with ceramic tilings. Its main purpose is to protect the edges of the tiles from deterioration owing to mechanical stresses.



Longitud 2,50 m. Embalaje: 10 u/caja.
Lenght 8,2 ft. Packing: 10 u/box.

Precio/Price: € /perfil

Referencia Reference	Colores Colours	h: 10 mm 3/8"	h: 12 mm 1/2"
150A-PB	Plata Brillo	15,58	16,64
150A-PM	Plata Mate	12,36	13,26

Con film protector / With protective tape. AISI - 304
Gama de color / Colour range. Pag.168



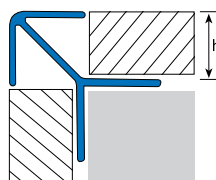
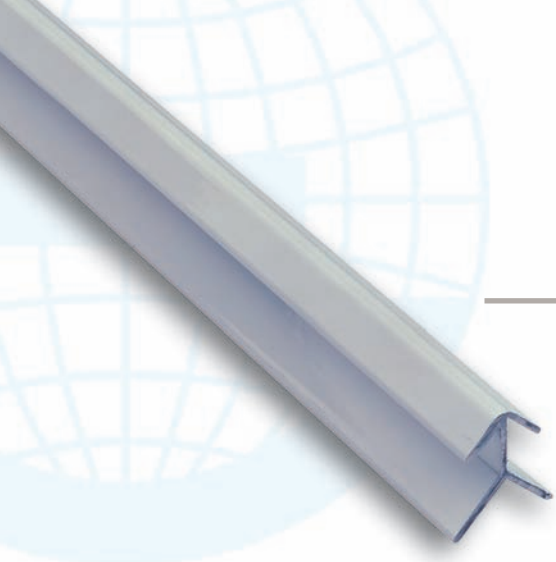

ES EUROCORNER-200A, perfil de aluminio destinado a las esquinas exteriores, gracias a sus dos cantos en ángulo recto proporciona una protección total al revestimiento de ambas paredes.

EN EUROCORNER-200A, this aluminium profile is used for external corners, thanks to its two edges in right angle provide a complete protection for the tiling of both walls.



Longitud 2,50 m. Embalaje: 10 u/caja.

Lenght: 8,2 ft. Packing: 10 u/box.

Precio/Price: € /perfil

Referencia Reference	Colores Colours	h: 11 mm 7/16"
200A-BL	Blanco	18,36
200A-PB	Plata Brillo	19,37
200A-OB	Oro Brillo	19,97

Con film protector / With protective tape.



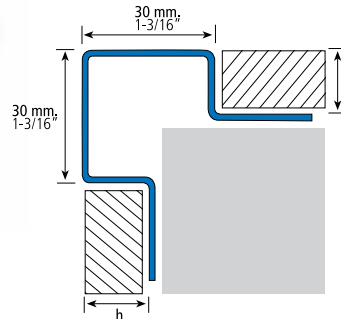
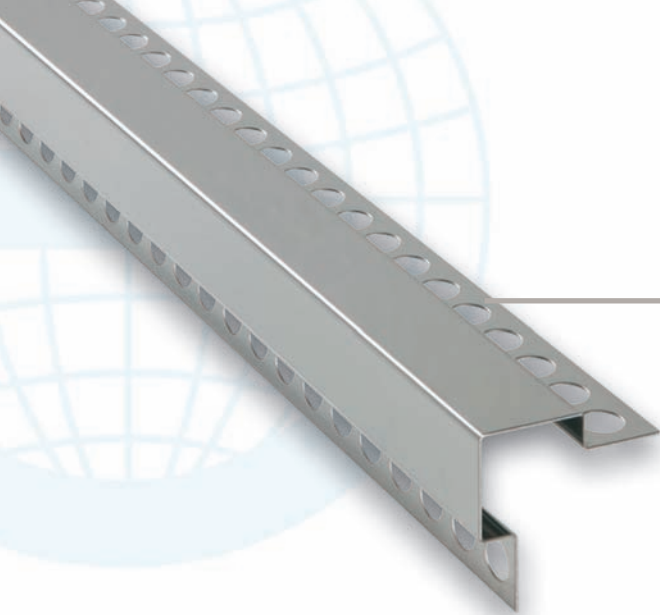

ES EUROCANTO-239S, perfil de acero inoxidable destinado a esquinas exteriores en revestimientos cerámicos. Su principal función es proteger los cantos del azulejo de los deterioros debidos a esfuerzos mecánicos. El EUROCANTO-239S proporciona una parte vista de 30 mm a ambos lados de la esquina, para así obtener acabados simétricos y elegantes.

EN EUROCORNER-239S, stainless steel profile applied for external corners in ceramic tilings. Its main purpose is to protect the tiles' edges from damages caused by mechanical stress. EUROCORNER-239S provides a 30 mm visible part on both sides of the corner to achieve symmetrical and elegant finishings.



Longitud 2,50 m. Embalaje: 10 u/caja.

Length: 8,2 ft. Packing: 10 u/box.

Precio/Price: € /perfil

Referencia Reference	Colores Colours	h: 10 mm 3/8"
239S-IB	Inox Brillo	41,93
239S-IC	Inox Cepillado	41,93

Con film protector / With protective tape. AISI - 304

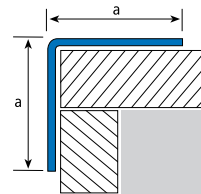

193A

193S

(A) Aluminio/Aluminium (S) Inoxidable/Inox

ES EUROÁNGULO, perfil para el remate de esquinas, utilizado una vez finalizada la obra o en reformas para proteger las esquinas dañadas. Recomendado para zonas sometidas a un fuerte desgaste, así como en aquellos lugares en los que se necesita una mayor higiene como por ejemplo hospitales, industrias alimentarias, cocinas industriales, etc., proporcionando un acabado limpio y decorativo en las esquinas de las paredes.

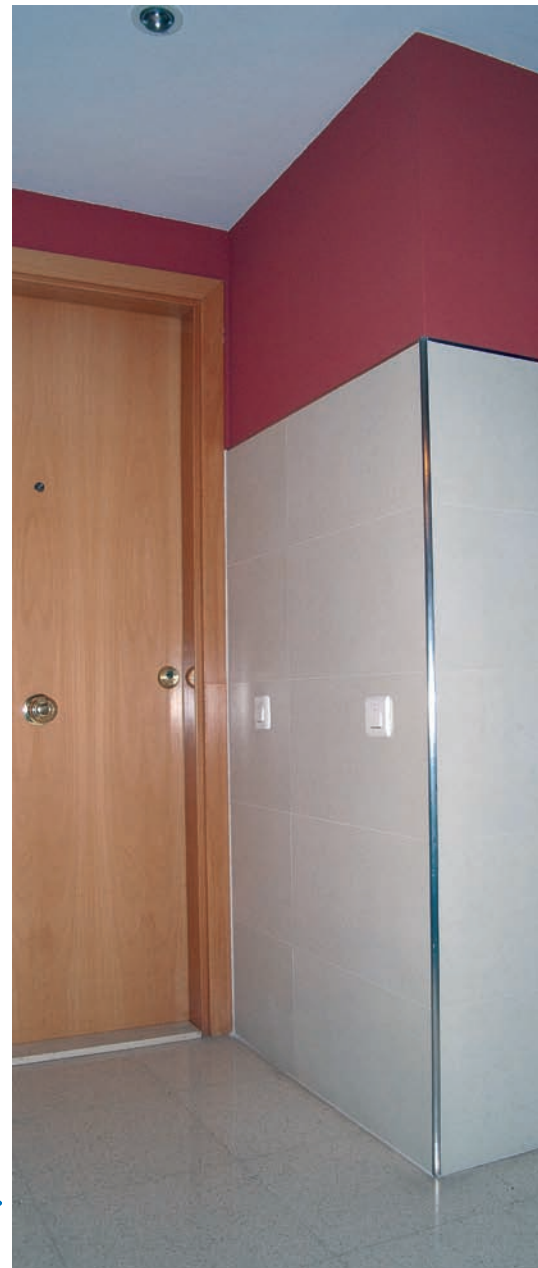
EN EUROANGLE, profile for the finishing of corners which is used after completing the construction work or renovation to protect damaged corners. It is recommended for areas of great wear and tear and places where special hygienic conditions are required, such as hospitals, the food industry, industrial kitchens, etc., providing a clean and decorative finishing in the corners of walls.

Aluminio - Longitud 2,50 m. Embalaje: 10 u/caja.

Aluminium - Length: 8,2 ft. Packing: 10 u/box.

Precio/Price: € /perfil

Referencia Reference	Colores Colours	a: 15 mm x 15 mm 9/16" x 9/16"	a: 25 mm x 25 mm 1" x 1"
193A-BL	Blanco	7,68	14,02
193A-PB	Plata brillo	8,15	14,74
193A-PM	Plata mate	7,35	13,69
New 193A-NM	Negro mate	8,82	16,42
193A-NO	Nogal		21,45
193A-RO	Roble		21,45

Acero inoxidable - Longitud 2,50 m. Embalaje: 20 u/caja (25x25) - 10 u/caja (50x50)

Stainless steel - Length: 8,2 ft. Packing: 20 u/box (25x25) -10 u/box (50x50)

Referencia Reference	Colores Colours	a: 15 x 15 mm 9/16" x 9/16"	a: 25 x 25 mm 1" x 1"	a: 50 x 50 mm 2" x 2"
193S-IB	Inox brillo	11,49	14,41	33,17
193S-IC	Inox cepillado	11,49	14,41	33,17

 Con film protector / With protective tape.
 Gama de color / Colour range. Pag.167/168

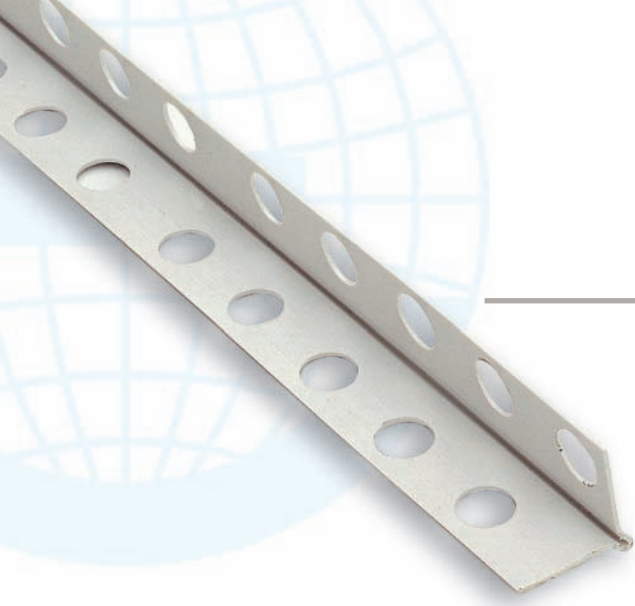

ES EUROYESO-169, perfil de PVC para las esquinas del enyesado protegiéndolas contra roturas provocadas por golpes. Al ser un producto de extrusión de compuesto vinílico no corrosivo da un mejor resultado que el metálico y no se oxida.

EN EUROPLASTER-169, PVC profile for corners of plasterwork, protecting them against breakage caused by impacts. Being a non-corrosive vinyl compound extrusion product it provides better results than metal and does not rust.

Longitud 2,50 m. Embalaje: 100 u/caja.

Lenght: 8,20 ft. Packing: 100 u/box.

Precio/Price: € /perfil

Referencia Reference	Colores Colours	
169-BL	Blanco	1,92

Serie RUSTIC
PVC de última generación
con fibras naturales recicladas.
*RUSTIC range made with last
generation of PVC with natural
recycled fibers.*





Amplia gama de listelos para el acabado decorativo de todo tipo de ambiente, desde el más moderno y vanguardista al clásico y acogedor rústico. La mayoría tienen varios usos, aparte de listelo, se pueden usar como separador de ambientes, cantoneras, remate de escalones, etc.

A wide range of listellos can be used to finish up decorations of all kinds of rooms, from ultramodern over avant-garde to welcoming-rural. Most of these products can be used in many different ways: as room dividers, corner pieces, finishing for steps, and more.

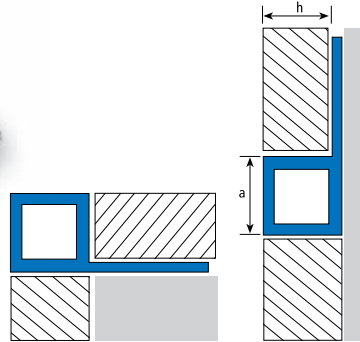
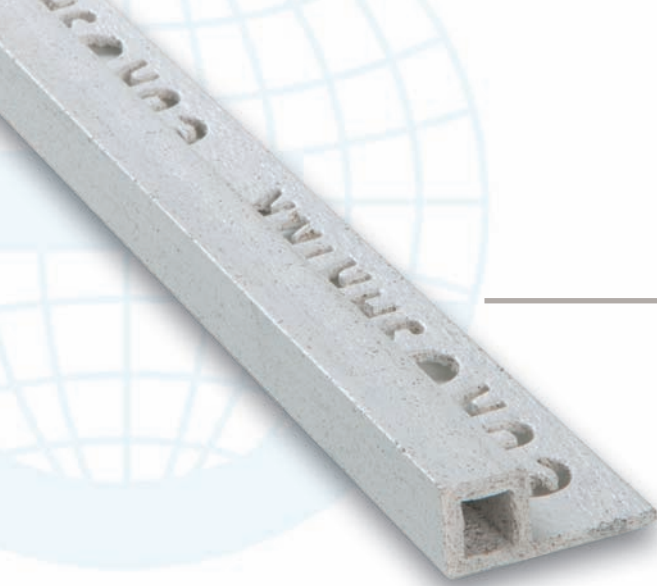

ES EUROMULTIUSOS-212 y 212R, perfil en PVC o PVC + FN (rústico) para múltiples usos: Listelo decorativo, Cantонера, Remate en suelos y paredes, Peldaños, Separador, ...

La parte vista del perfil nos proporciona un canto cuadrado que complementa la esquina de los revestimientos cerámicos, dándonos un acabado perfecto en la línea estética y de diseño que marcan las nuevas tendencias en interiorismo. **El EUROMULTIUSOS-212R** se fabrica con un **PVC especial con fibras naturales recicladas**, gracias a las cuales ofrece un acabado rugoso que se amolda perfectamente a los revestimientos rústicos o no uniformes que se encuentran en el mercado actual.

EUROSHRINK apuesta por nuevos componentes que son por supuesto 100% reciclables.

EN EUROMULTIPURPOSE-212 & 212R, PVC or PVC + FN (rustic) profile suitable for many different applications, including: Decorative listello, Edge protection, Finishing on floors and walls, Steps, Dividers, ...

The visible section of the stripping provides a square edge which complements the corner of ceramic tilings, giving a perfect finishing which complies with the aesthetics and design according to the new trends in interior design. The **EUROMULTIPURPOSE-212R** is made with a special **PVC including natural recycled fibers**, it presents a rough finishing that adjusts perfectly to rustic or uniform tilings which can be found on the current market.

EUROSHRINK is increasingly committed to new components that can be recycled entirely.

PVC - Longitud 2,55 m. Embalaje: 50 u/caja.

PVC - Length 8,36 ft. Packing: 50 u/box.

Precio/Price: € /perfil

Referencia Reference	Colores Colours		h: 10 mm 3/8"	h: 12 mm 1/2"
212-BL	Blanco (BL)		3,37	3,62
212-CR	Crema (CR)		3,37	3,62
212-GC	Gris claro (GC)		3,37	3,62
212-NE	Negro (NE)		3,37	3,62

Rústico PVC + FN - Longitud 2,55 m. Embalaje: 50 u/caja.

Rustic range PVC + FN - Length 8,36 ft. Packing: 50 u/box.

Precio/Price: € /perfil

Referencia Reference	Colores Colours		h: 10 mm 3/8"	h: 12 mm 1/2"
212R-BL	Blanco (BL)		9,93	10,26
212R-CR	Crema (CR)		9,93	10,26
212R-HU	Hueso (HU)		9,93	10,26
212R-CH	Champagne (CH)		9,93	10,26
212R-BG	Beige G (BG)		9,93	10,26
212R-CAR	Caramelo (CAR)		9,93	10,26
212R-MC	Marron claro (MC)		9,93	10,26
212R-MAD	Madera (MAD)		9,93	10,26
212R-MA	Marron (MA)		9,93	10,26
212R-GR	Gris (GR)		9,93	10,26
212R-CEN	Ceniza (CEN)		9,93	10,26
212R-GFT	Grafito (GFT)		9,93	10,26
212R-PIZ	Pizarra (PIZ)		9,93	10,26
212R-NE	Negro (NE)		9,93	10,26

Gama de rústicos PVC + FN / Rustic range PVC + FN Pag. 167
Gama de color / Colour range. Pag.166/167



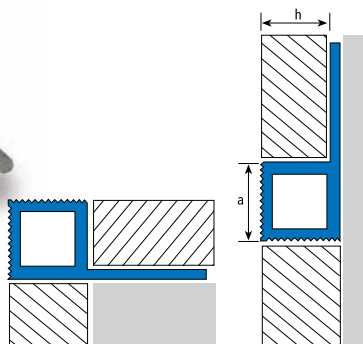
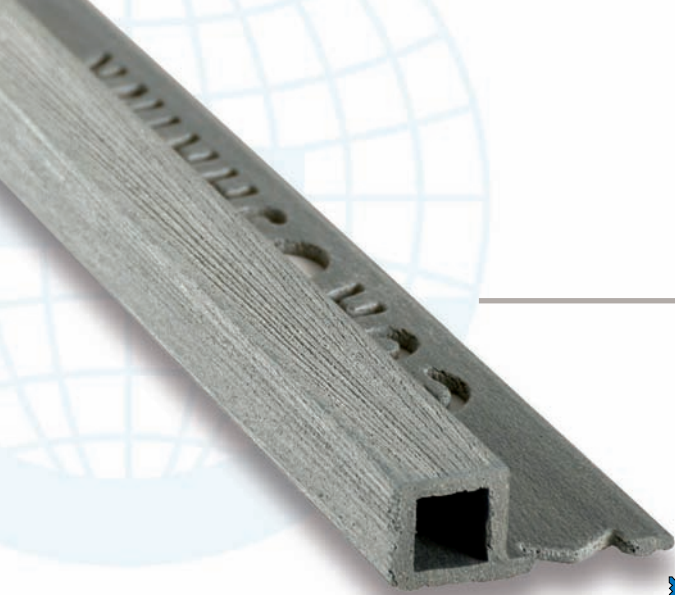

ES EUROMULTIUSOS 212R TEXTURA, perfil de PVC + FN para múltiples usos: listelo decorativo, cantonera, separador, ... La parte visible del perfil de canto cuadrado complementa la esquina de los revestimientos cerámicos, proporcionando un acabado perfecto. Fabricado en PVC especial con fibras naturales recicladas, gracias a las cuáles y su acabado estriado ofrece un acabado rugoso que se amolda perfectamente a los revestimientos rústicos o no uniformes del mercado. Desarrollado específicamente para su uso en exteriores. EUROSHRINK apuesta por nuevos componentes que son por supuesto 100% reciclables y que contribuyen a la conservación del medio ambiente

EN EUROMULTIPURPOSE 212R TEXTURA, PVC + FN profile for multiple uses: decorative tiling, corner piecing, separators... The visible part of the square edge profile complements the corner of ceramic coatings, providing a perfect finish. Manufactured in special PVC with recycled natural fibres and a fluted finish, which offers a coarse finish that moulds perfectly to the rustic or non-uniform coatings on the market. Developed specifically to be used outdoors. EUROSHRINK is committed to new components that are of course 100% recyclable and contribute to preserving the environment.



Textura Blanco (TX/BL) Textura Beige (TX/BG) Textura Marron claro (TX/MC) Textura Marron (TX/MA) Textura Ceniza (TX/CE) Textura Pizarra (TX/PIZ) Textura Negro (TX/NE)

Rustico PVC + FN - Longitud 2,55 m. Embalaje: 50 u/caja.
Rustic range PVC + FN - Length 8,36 ft. Packing: 50 u/box.

Precio/Price: € /perfil

Referencia Reference	Colores Colours	h: 12,5 mm 1/2"
212R-TX/BL	Textura Blanco (TX/BL)	14,85
212R-TX/BG	Textura Beige G (TX/BG)	14,85
212R-TX/MC	Textura Marron claro (TX/MC)	14,85
212R-TX/MA	Textura Marron (TX/MA)	14,85
212R-TX/CE	Textura Ceniza (TX/CE)	14,85
212R-TX/PIZ	Textura Pizarra (TX/PIZ)	14,85
212R-TX/NE	Textura Negro (TX/NE)	14,85



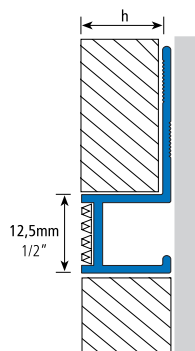
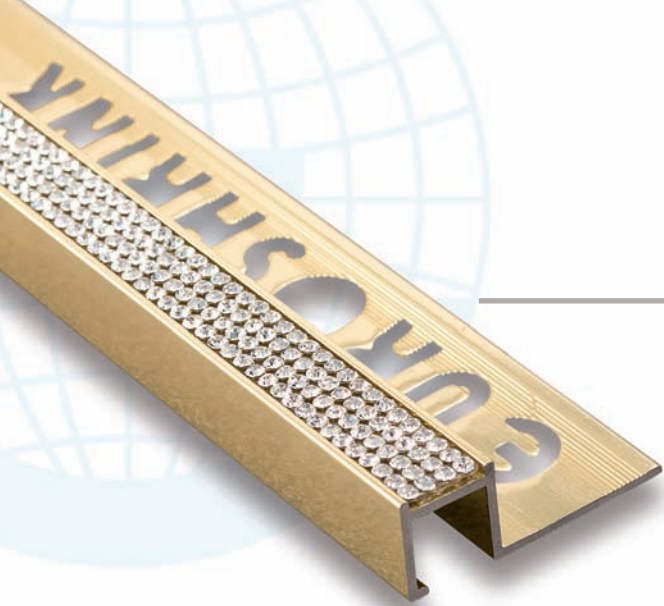

ES EUROLISTELO 212A/CRYSTAL, Listelo decorativo para obtener un espacio elegante y moderno. Los prismas de cristal incrustados en el frontal multiplican las luces y crean brillos proporcionando un aire distinguido a cualquier ambiente.

EN EUROLISTELLO 212A/CRYSTAL, Decorative listello for an elegant and modern space. The glass prisms embedded in the front surface reflects lights and generates sparkle, providing a distinguished air for any environment.



212A-PB/CRYSTAL



212A-OB/CRYSTAL

Longitud 2,50 m. Embalaje: 10 u/caja.

Lenght: 8,2 ft. Packing: 10 u/box.

Precio/Price: € /perfil

Referencia Reference	Colores Colours	h: 12 mm 1/2"
212A-PB/Crystal	Plata brillo	38,50
212A-OB/Crystal	Oro brillo	39,00

Con film protector / With protective tape.



212A



ECO 212A

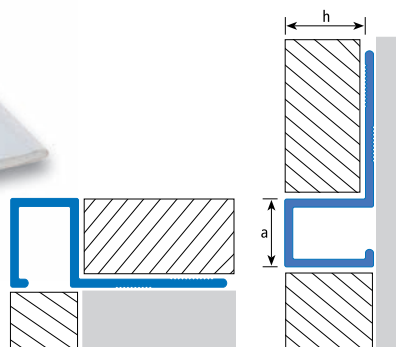

(A) Aluminio/Aluminium

ES EUROMULTIUSOS, perfil para múltiples usos: Listelo decorativo, Cantonera, Remate en suelos y paredes, Peldaños, Separador, ...

La parte vista del perfil nos proporciona un canto cuadrado que complementa la esquina de los revestimientos cerámicos, dándonos un acabado perfecto en la línea estética y de diseño que marcan las nuevas tendencias en interiorismo. Su uso es adecuado tanto en viviendas particulares como en obras públicas o industriales. Para obtener un acabado impecable en las esquinas exteriores, el **EUROMULTIUSOS-212A** se complementa con piezas finales especiales, referencia E212A.

EN EUROMULTIPURPOSE, aluminium profile suitable for many different applications, including: Decorative listello, Edge protection, Finishing on floors and walls, Steps, Dividers, ...

The visible section of the stripping provides a square edge which complements the corner of ceramic tilings, giving a perfect finishing which complies with the aesthetics and design according to the new trends in interior design. Their application is adequate for private housings, as well as for public or industrial construction work. In order to obtain an impeccable finishing of the external corners, the **EUROMULTIPURPOSE-212A** is supplemented with special final pieces, reference E212A.

Aluminio - Longitud 2,50 m. Embalaje: 10 u/caja.

Aluminium - Length: 8,2 ft. Packing: 10 u/box.

Precio/Price: € /perfil

Referencia Reference	Colores Colours	h: 6 mm 1/4"	h: 8 mm 5/16"	h: 10 mm 3/8"	h: 12 mm 1/2"	h: 15 mm 9/16"
212A-BL	Blanco		€ 15,76	€ 17,20	€ 17,78	
212A-CR	Crema			€ 17,20	€ 17,78	
212A-PB	Plata brillo	12,62	€ 12,58	€ 14,02	€ 14,69	€ 23,34
212A-PM	Plata mate	10,29	€ 10,79	€ 12,69	€ 13,36	€ 18,69
212A-PC	Plata cepillado		€ 15,76	€ 17,20	€ 17,78	
212A-OB	Oro brillo			€ 15,69	€ 16,36	
212A-OM	Oro mate			€ 12,74	€ 13,36	
212A-BRM	Bronce mate			€ 17,20	€ 17,78	
212A-NM	Negro mate			€ 17,20	€ 17,78	
212A-NEB	Negro brillo				€ 18,85	
212A-CHB	Champagne brillo				€ 20,22	
212A-CHC	Champagne cepillado				€ 24,11	
212A-ORS	Oro rosa brillo				€ 17,36	
212A-ORC	Oro rosa cepillado				€ 17,36	
E-212A (esquina exterior / external corner)		Blister: 1 u.				
E-212A	€		7,87	7,87	8,40	8,61

Aluminio - Longitud 2,50 m. Embalaje: 50 u/caja.

Aluminium - Length: 8,2 ft. Packing: 50 u/box.

ECO 212A	Plata brillo			9,68	10,02	
ECO 212A	Plata mate			8,68	8,68	
ECO 212A	Blanco			9,26	9,26	

Gama de color / Colour range. Pag.168 Con film protector / With protective tape.



GAMA NATURA.
Innovando con lo clásico.
Ampliamos el clásico Euromultiusos:
Colores y texturas inspiradas en la naturaleza;
maderas cálidas y arenas sobrias que aportarán
serenidad a tu hogar.

NATURA RANGE.
Innovating yet classic.
We have expanded the classic Euromultiusos:
colours and textures inspired by nature;
warm woods and sober sands which will lend peace
of mind to your home.



Arena Camel / Camel Sand

Arena Gris Claro / Light Grey Sand

Arena Gris / Grey Sand

Arena Marron / Brown Sand

Arena Oxido / Oxide Sand

Arena Antracta / Anthracite Sand

Arena Negro / Black Sand

GAMA NATURA.
 Innovando con lo clásico.
 Ampliamos el clásico Euromultiusos:
 Colores y texturas inspiradas en la naturaleza;
 maderas cálidas y arenas sobrias que aportarán
 serenidad a tu hogar.

NATURA RANGE.
 Innovating yet classic.
 We have expanded the classic Euromultiusos:
 colours and textures inspired by nature;
 warm woods and sober sands which will lend peace
 of mind to your home.

Aluminio - longitud: 2,50 m. Embalaje: 10 u/caja.
 Aluminium - Length: 8,2 ft. Packing: 10 u/box.

Precio/Price: € /Perfil

Ref. Ref.	Colores Colours	h: 12 mm 1/2"
212A-RC	Roble Claro	20,10
212A-RN	Roble Natural	20,10
212A-MGC	Madera G. Claro	20,10
212A-RO	Roble	20,10
212A-NO	Nogal	20,10
212A-ARBE	Arena Beige	€ 17,50
212A-ARGR	Arena Gris	€ 17,50
212A-ARAN	Arena Antracita	€ 17,50
212A-ARCA	Arena Camel	€ 17,50
212A-ARGC	Arena Gris Claro	€ 17,50
212A-ARMA	Arena Marron	€ 17,50
212A-AROX	Arena Oxido	€ 17,50
212A-ARNE	Arena Negro	€ 17,50
	E-212A (Esquina exterior / External corner)	Blister: 1 u.
E-212A	€	8,40

New
colours

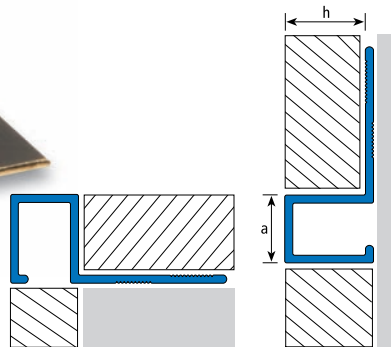
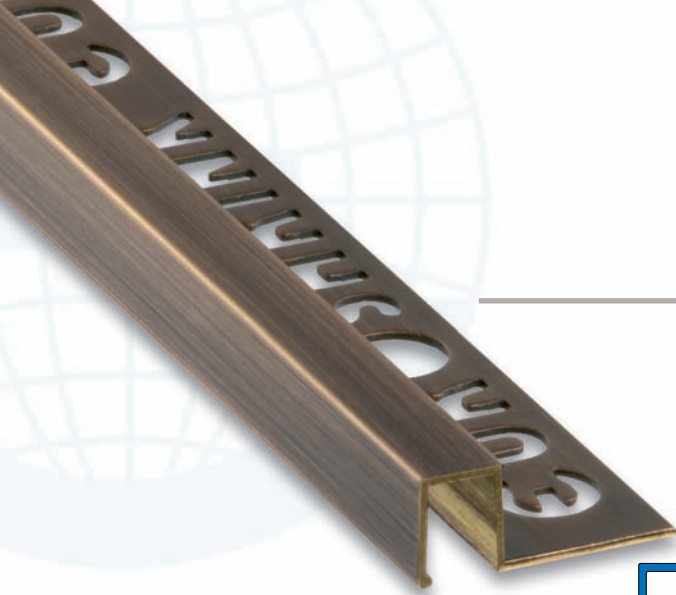

(L) Laton/Brass

ES EUROMULTIUSOS-212L, Perfil de latón para múltiples usos: listelo decorativo, cantonera, separador, ... La parte vista del perfil nos proporciona un canto cuadrado que complementa la esquina de los revestimientos cerámicos. Disponibilidad de nueva gama de color (cobre y bronce envejecido), el remate perfecto para las nuevas tendencias en diseño de interiores aportando fuerza y carácter a cualquier rincón de tu casa

EN EUROMULTIPURPOSE-212L, a multi-purpose brass profile: decorative beading, corner piece, partitions, ... The visible part of the profile features a square edge that complements the corner of the ceramic wall tiles. Available in a new range of colours (copper and aged bronze), the perfect finish for new trends in interior design, adding strength and character to any corner of your home..



212L Latón cromado / Chrome brass



212L-CRO-10/12 Latón cromado



212L-ABR-12 Antique bronze



212L-ABR-12 Antique cooper

Latón - Longitud 2,50 m. Embalaje: 20 u/caja.

Brass - Lenght: 8,2 ft. Packing: 20 u/box.

Precio/Price: € /perfil

Referencia Reference	Colores Colours	h: 10 mm 3/8"	h: 12 mm 1/2"
212L-CRO	Latón cromado	€ 105,35	€ 111,27
212L-ABR	Antique bronze		€ 102,39
212L-ACO	Antique cooper		€ 102,39
 E-212L (esquina exterior / external corner)			Blister: 1 u.
E-212L	€		16,57

Con film protector / With protective tape.

*E-212L sólo en altura 12 mm / E-212L in 12 mm height only.



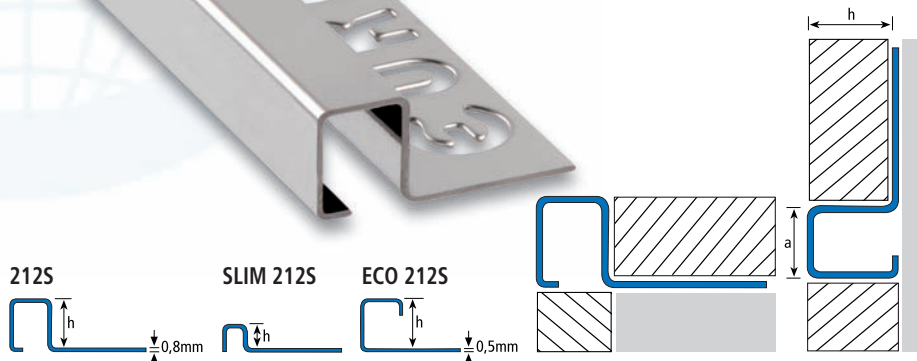

ES EUROMULTIUSOS-212S, perfil de acero inoxidable con múltiples usos: Listelo decorativo, Cantonera, Remate en suelos y paredes, Peldaños, Separado,
La parte vista del perfil proporciona un canto cuadrado que complementa la esquina de los revestimientos cerámicos, dándoles un acabado estético perfecto siguiendo las líneas de diseño que marcan las nuevas tendencias en interiorismo. Este mismo canto cuadrado proporciona un perfecto separador de ambientes en suelos, o simplemente como decoración en el mismo, por su alta dureza y resistencia. El perfil se suministra con un film protector, que debe ser retirado una vez finalizada la instalación del mismo, que garantiza la durabilidad y el brillo del perfil. Su uso es adecuado tanto en viviendas particulares como en obras públicas o industriales. Este perfil se complementa con unas piezas finales especiales, ref. E212S

EN EUROMULTIPURPOSE-212S, stainless steel profile suitable for a many different applications, including: Decorative listello, Edge protection, Finishing on floors and walls, Steps, Dividers, ...
The visible section of the profile supplies a square edge which complement the corner of ceramic tilings, providing a perfect aesthetical finishing which complies with the aesthetics and design according to the new trends in interior design. This square edge gives a perfect area divider on the floor, because of its high level of hardness and resistance, and it also can be used as a decorative element. Its use is indicated both in private housings and in public or industrial construction work. The profile is supplied with a protection film which grants the durability and gloss. Once the installation is finished, it has to be removed. This profile has special connecting pieces, ref. E-212S



Acero inoxidable - Longitud 2,50 m. Embalaje: 20 u/caja.
Stainless steel - Length: 8,2 ft. Packing: 20 u/box.

Precio/Price: € /perfil

Referencia Reference	Colores Colours	h: 4,5 mm 3/16"	h: 8 mm 5/16"	h: 10 mm 3/8"	h: 12 mm 1/2"	h: 15 mm 9/16"
SLIM 212S-IB	Inox brillo	19,51				
SLIM 212S-IC	Inox cepillado	19,51				
212S-IB	Inox brillo		€ 20,50	€ 21,43	€ 22,24	€ 26,34
212S-IC	Inox cepillado		€ 20,50	€ 21,43	€ 22,24	€ 26,34
212S-NEB	Negro brillo				€ 27,83	
212S-NEC	Negro cepillado				€ 27,83	
212S-COB	Cobre brillo				€ 27,83	
212S-COC	Cobre cepillado				€ 27,83	
212S-OB	Oro brillo				€ 27,83	
212S-OC	Oro cepillado				€ 27,83	
212S-OLBR	Old bronze				€ 34,79	
212S-OLCO	Old copper				€ 34,79	



E-212S (esquina exterior / external corner)

Blister: 1 u.

E-212S	€		6,21	7,21	8,70	9,50
--------	---	--	------	------	------	------

Acero inoxidable - Longitud 2,50 m. Embalaje: 20 u/caja.
Stainless steel - Length: 8,2 ft. Packing: 20 u/box.

ECO 212S-IB	Inox brillo				15,53	
ECO 212S-IC	Inox cepillado				15,53	

Con film protector / With protective tape. /AISI-304





GAMA ACERO INOXIDABLE
STAINLES STEEL RANGE

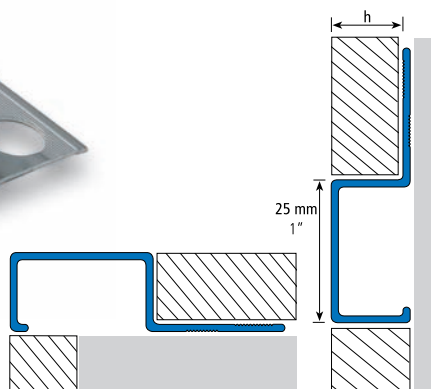
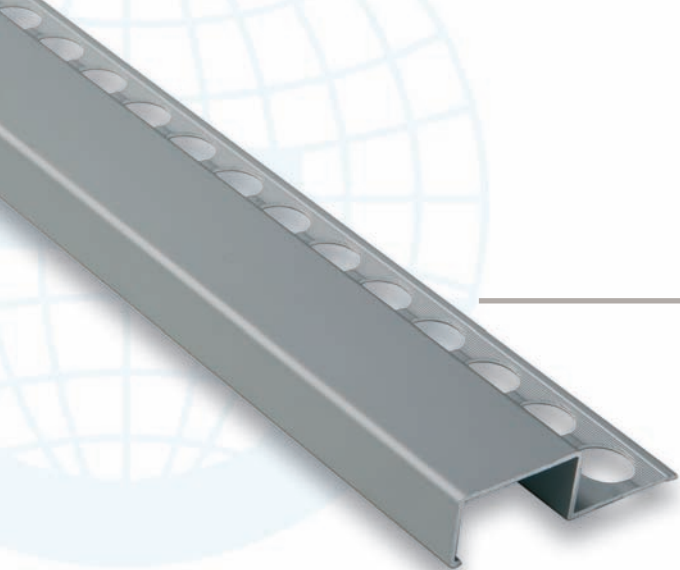

(A) Aluminio/Aluminium
(A) Acero inoxidable / Stainless Steel

ES EUROMULTIUSOS, perfil para protección de los cantos de los revestimientos cerámicos con múltiples usos: Listelo decorativo, Cantonera, Remate en suelos y paredes, Peldaños, Separador, ... Multiusos asimétrico con una parte vista de 25 mm que proporciona una mayor vistosidad a los espacios más vanguardistas, facilitando su combinación con cualquier tipo de revestimiento. La parte vista del perfil nos proporciona un canto asimétrico que complementa la esquina de los revestimientos cerámicos, dándonos un acabado perfecto en la línea estética y de diseño actuales. Su uso es adecuado tanto en viviendas particulares como en obras públicas o industriales, en interiores o exteriores.

EN EUROMULTIPURPOSE, profile used for protecting the edges of ceramic tilings with multiple purposes: Decorative listello, Edge protection, Finishing on floors and walls, Steps, Dividers, ... Asymmetrical multipurpose profile with a visible part of 25 mm which add to the appearance of the most avant-garde rooms, and can be combined with any kind of tiling. The visible section of the stripping provides an asymmetrical edge which complements the corners of ceramic tilings, giving a perfect finishing which complies with the aesthetics and design according to the new trends in design. Their application is adequate for private housings, as well as for public or industrial construction work.



Aluminio - Longitud 2,50 m. Embalaje: 10 u/caja.

Aluminium - Length: 8,2 ft. Packing: 10 u/box.

Precio/Price: € /perfil

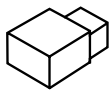
Referencia Reference	Colores Colours	h: 12 mm 1/2"
213A-PB	Plata brillo	€ 18,43
213A-PM	Plata mate	€ 17,10
 E-213A (esquina exterior / external corner)		Blister: 1 u.
E-213A	€	10,29

Acero inoxidable - Longitud 2,50 m. Embalaje: 20 u/caja.

Stainless steel - Length: 8,2 ft. Packing: 20 u/box.

213S-IB	Inox brillo	27,83
213S-IC	Inox cepillado	27,83

Con film protector / With protective tape.

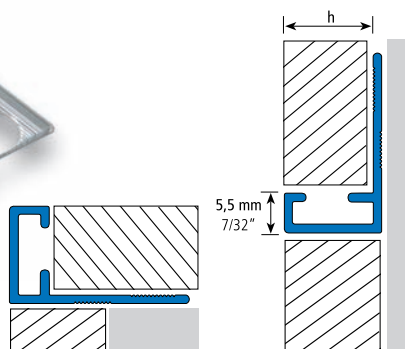
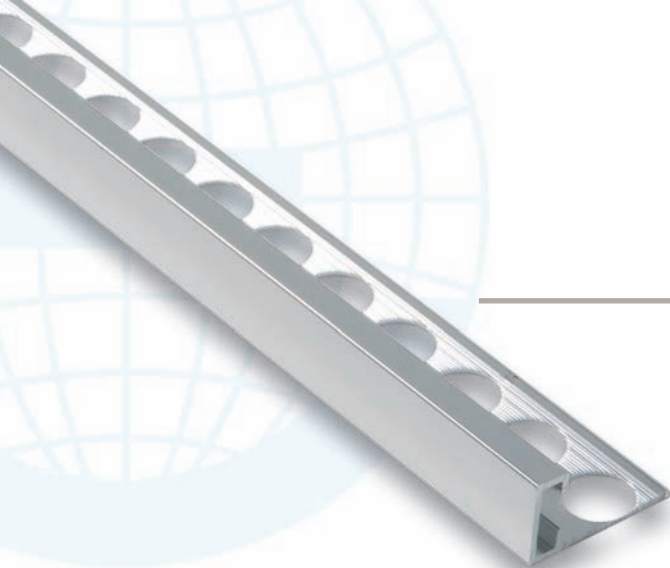

ES EUROMULTIUSOS-230A, perfil de aluminio para múltiples usos: Listelo decorativo, Cantonera, Remate en suelos y paredes, Peldaños, Separador, ...

Multiusos minimalista con una parte vista de 5,5 mm para obtener un toque elegante y discreto en los espacios más exigentes. El canto del perfil complementa la esquina de los revestimientos cerámicos, dándole un acabado perfecto a cualquier esquina, tanto en espacios interiores como exteriores. Puede ser usado en combinación con cualquier tipo de revestimiento. Su uso es adecuado tanto en viviendas particulares como en obras públicas o industriales.

EN EUROMULTIPURPOSE-230A, aluminium profiles with multiple purposes: Decorative listello, Edge protection, Finishing on floors and walls, Steps, Dividers, ...

Minimalist multipurpose tiling with a visible part of 5,5 mm that gives an elegant and unobtrusive touch to the most demanding rooms. The profile's edge complements the corner of ceramic tilings giving them a perfect finishing in any kind of corner. It can be combined with any kind of tiling, and is suitable in private homes and in public or industrial buildings.



Longitud 2,50 m. Embalaje: 10 u/caja.

Lenght: 8,2 ft. Packing: 10 u/box.

Precio/Price: € /perfil

Referencia Reference	Colores Colours	h: 12 mm 1/2"
230A-PB	Plata brillo	16,30
230A-PM	Plata mate	12,74

Con film protector / With protective tape.

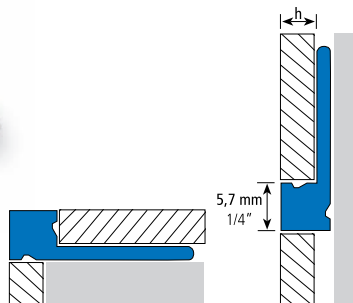
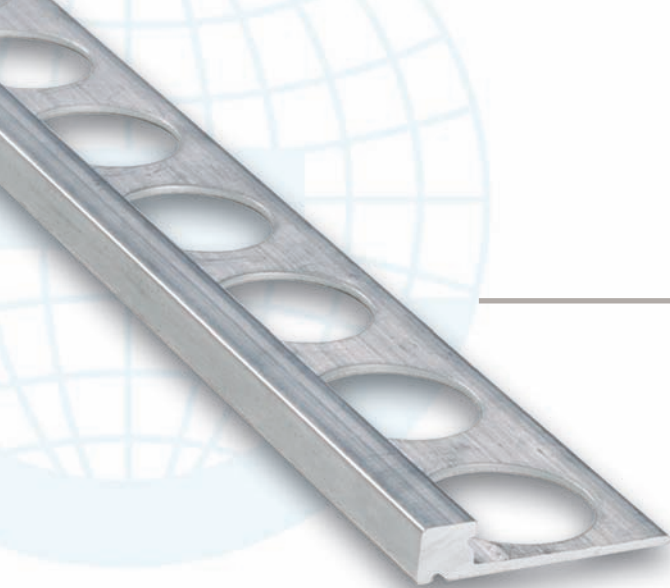

ES EUROMULTIUSOS-246A, perfil de aluminio para múltiples usos: Listelo decorativo, Cantonera, Remate en suelos y paredes, Peldaños, Separador, ...
Perfil diseñado específicamente para su uso con mosaicos, gresite o cerámica de bajo espesor, con una altura máxima de 4,5 mm.

EN EUROMULTIPURPOSE-246A, aluminium profile suitable for many different applications, including: Decorative listello, Edge protection, Finishing on floors and walls, Steps, Dividers, ...
This profile was especially designed for its use in mosaics, gresite or ceramic tiles of low thickness with a maximum height of 4.5 mm.



Longitud 2,50 m. Embalaje: 10 u/caja.
Lenght: 8,2 ft. Packing: 10 u/box.

Precio/Price: € /perfil

Referencia Reference	Colores Colours	h: 4,5 mm 3/16"
246A-BL	Blanco	14,46
246A-PB	Plata brillo	17,61
246A-PM	Plata mate	14,22
246A-NM	Negro mate	17,80

Con film protector / With protective tape.

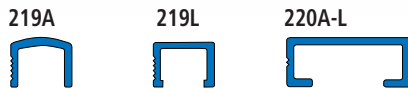

(A) Aluminio/Aluminium (L) Laton/Brass

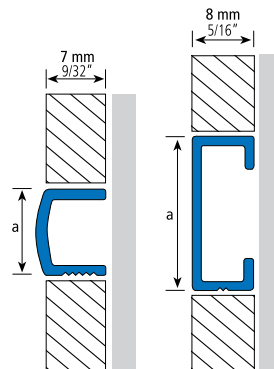

220L Latón cromado / Chrome brass

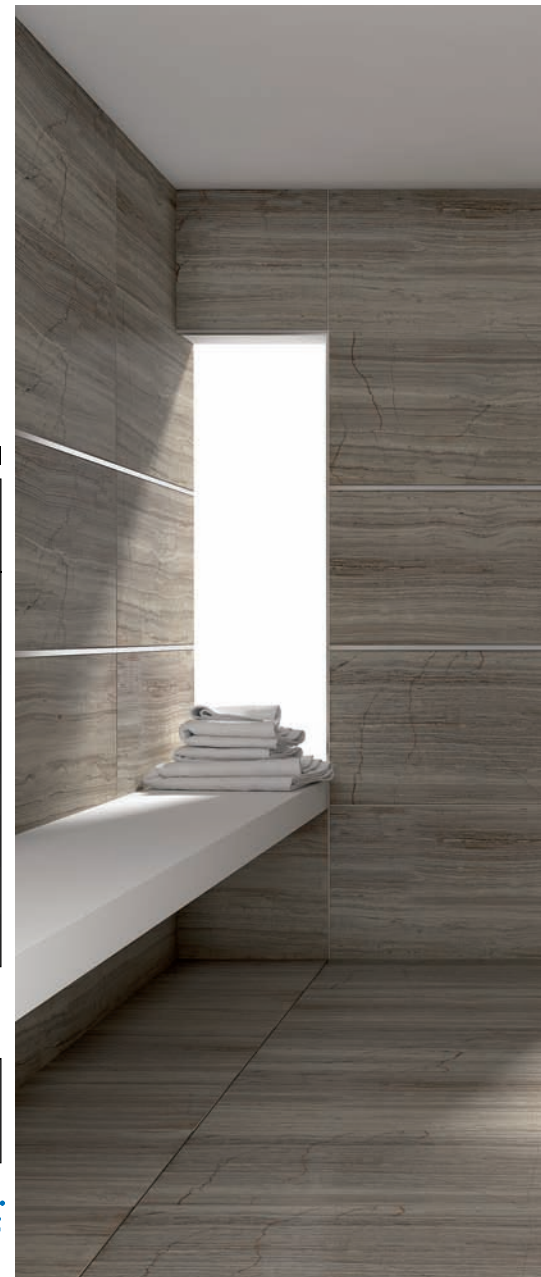

ES EUROLISTELO, listelos que se adaptan perfectamente a las nuevas tendencias decorativas marcadas por el mercado actual. Con una altura de 7 mm (219) y 8 mm (220), permiten su uso con todas las alturas de pavimentos y revestimientos existentes. Desarrollados para poder combinarse con nuestra amplia gama de perfiles (171, 183, 212, 191, etc.), para poder adaptarse a cualquier ambiente.

EN EUROLISTELLO, listellos that adapt perfectly to the new decorative design trends set by the current market. With a thickness of 7 mm (219) and 8 mm (220), they can be used with all the existing floorings and tilings heights. They were created to combine with our wide range of profiles (171, 183, 212, 191, etc.), which can be adapted to all kinds of surroundings.

Aluminio - Longitud 2,50 m. Embalaje: 10 u/caja.

Aluminium - Length: 8,2 ft. Packing: 10 u/box.

Precio/Price: € /perfil

Referencia Reference	Colores Colours	a: 10 mm 3/8"	a: 20 mm 3/4"
219A-PB	Plata brillo	8,76	
219A-PM	Plata mate	7,24	
219A-PC	Plata cepillado	9,93	
219A-OB	Oro brillo	9,25	
220A-PB	Plata brillo		14,89
220A-PM	Plata mate		11,76
220A-PC	Plata cepillado		15,93
220A-OB	Oro brillo		15,69

Latón cromado - Longitud 2,50 m. Embalaje: 20 u/caja.

Chrome brass - Length: 8,2 ft. Packing: 20 u/box.

219L-CRO	Latón cromado	61,55	
220L-CRO	Latón cromado		84,04

Con film protector / With protective tape.
Gama de color / Colour range. Pag.168

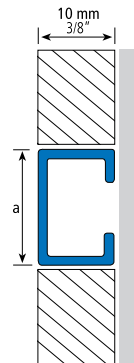
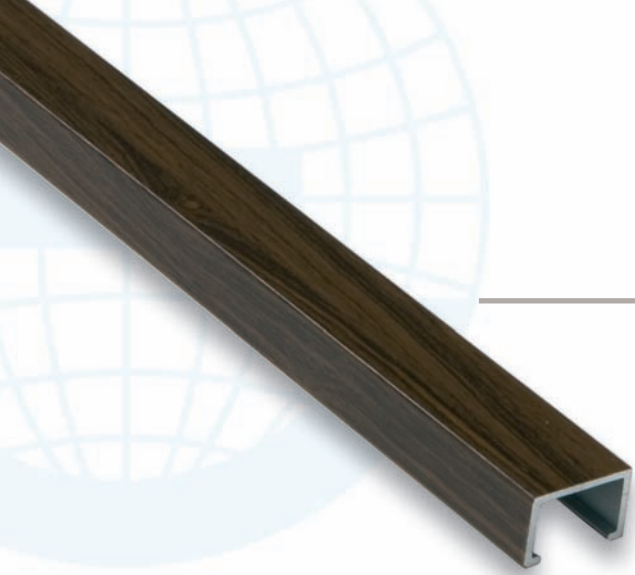

ES EUROLISTELO-225A, listelo de aluminio decorado en madera para obtener acabados cálidos y acogedores, creando ambientes con un toque noble y elegante. El perfil se ha recubierto con una lámina especial que imita perfectamente la textura y la veta de la madera, resistente al uso de productos de limpieza habituales.

EN EUROLISTELO-225A, aluminium listello decorated with wood. It presents a warm and cosy finishing, and creates a noble and elegant touch. The profile has been covered with a special sheet that generates a perfect imitation of a wooden texture and grain, is resistant to the common cleaning products.



Longitud 2,50 m. Embalaje: 10 u/caja.
Length: 8,2 ft. Packing: 10 u/box.

Precio/Price: € /perfil

Referencia Reference	Colores Colours	a: 15 mm 9/16"
225A-NO	Nogal	13,91
225A-RO	Roble	13,91

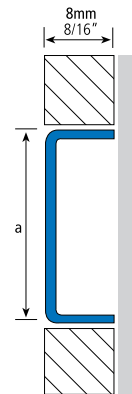
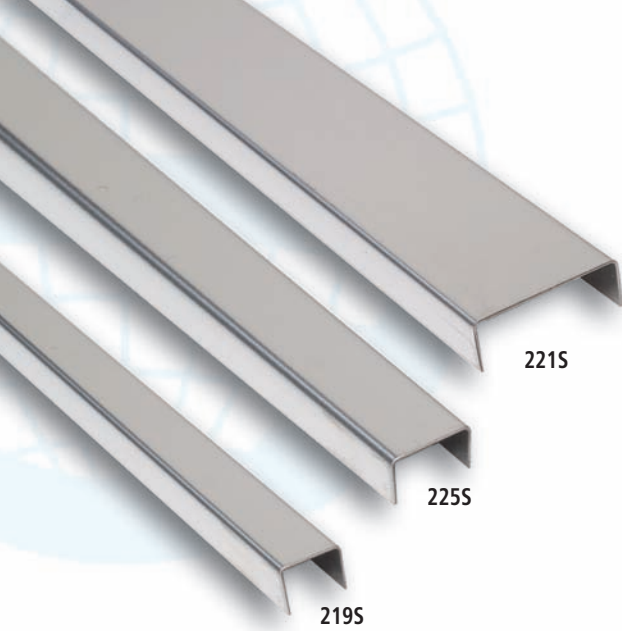

ES EUROLISTELO-219S, 225S y 221S, listelos de acero inoxidable que se adaptan perfectamente a las nuevas tendencias decorativas marcadas por el mercado actual. Desarrollados para poder combinarse con nuestra amplia gama de perfiles en acero inoxidable, (171S, 183S, 212S, etc.) y así poder adaptarlos a cualquier ambiente, incluso como diferenciador de espacios en el suelo, por su alta dureza y resistencia. Los EUROLISTELOS tienen una altura de 8 mm, por lo que en caso de utilizar cerámica o pavimento de mayor grosor se debe rellenar con cemento cola para igualar la diferencia.

EN EUROLISTELLO-219S, 225S and 221S, stainless steel listellos that perfectly match the new design trends in decoration set by the current market. They were developed to combine with our wide range of stainless steel profiles (171S, 183S, 212S, ...) and consequently be accommodated to any surrounding, functioning even as a room divider on floors due to their high level of hardness and resistance. EUROLISTELLO'S heightness is of 8 mm., this is why, when using ceramics or floorings with a greater thickness, they have to be filled with cement glue covering the difference, so as to achieve a better grip



Longitud 2,50 m. Embalaje: 20 u/caja.

Lenght: 8,2 ft. Packing: 20 u/box.

Precio/Price: € /perfil

Referencia Reference	Colores Colours	a: 10 mm 3/8"	a: 15 mm 9/16"	a: 25 mm 1"
219S-IB	Inox brillo	9,94		
219S-IC	Inox cepillado	9,94		
225S-IB	Inox brillo		10,56	
225S-IC	Inox cepillado		10,56	
225S-NEB	Negro brillo		13,23	
225S-NEC	Negro cepillado		13,23	
225S-COB	Cobre brillo		13,23	
225S-COC	Cobre cepillado		13,23	
225S-OB	Oro brillo		13,23	
225S-OC	Oro cepillado		13,23	
221S-IB	Inox brillo			12,55
221S-IC	Inox cepillado			12,55

Con film protector / With protective tape. / AISI-304
Gama de color / Colour range. Pag.167

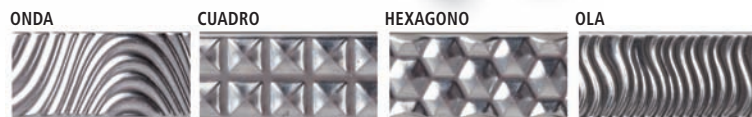
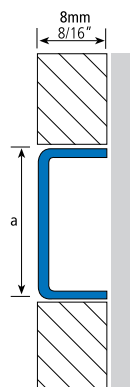
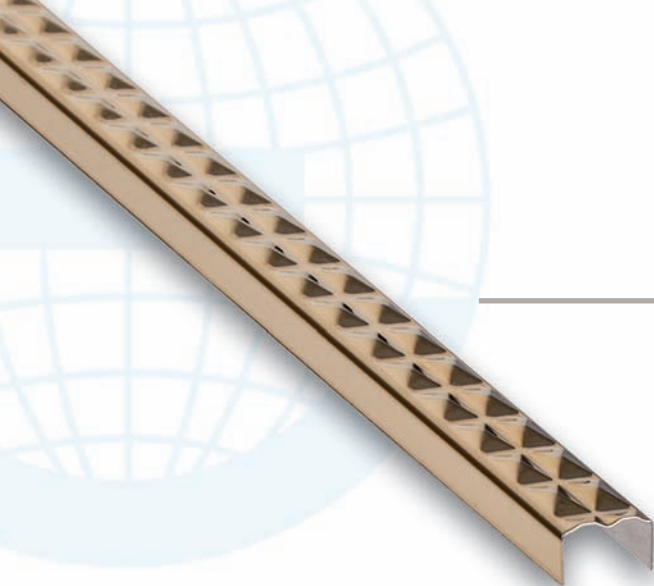

ES EUROLISTELO-220S, Listelo 3D de acero inoxidable de ancho 20 mm, con acabados en relieve para proporcionar una decoración moderna y vanguardista.

EN EUROLISTELLO-220S, 20 mm wide 3D stainless steel listello with finishes in relief to afford modern, avant-garde decoration.



Longitud 2,50 m. Embalaje: 20 u/caja.

Lenght: 8,2 ft. Packing: 20 u/box.

Precio/Price: € /perfil

Referencia Reference	Colores Colours	a: 20 mm 3/4"
220S-IB/CU	Inox brillo / CUADRO	14,29
220S-OB/CU	Oro brillo / CUADRO	17,89
220S-IB/ON	Inox brillo / ONDA	14,29
220S-OB/ON	Oro brillo / ONDA	17,89
220S-IB/HE	Inox brillo / HEXAGONO	14,29
220S-IB/OL	Inox brillo / OLA	14,29

Con film protector / With protective tape. / AISI-304

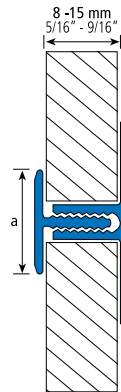
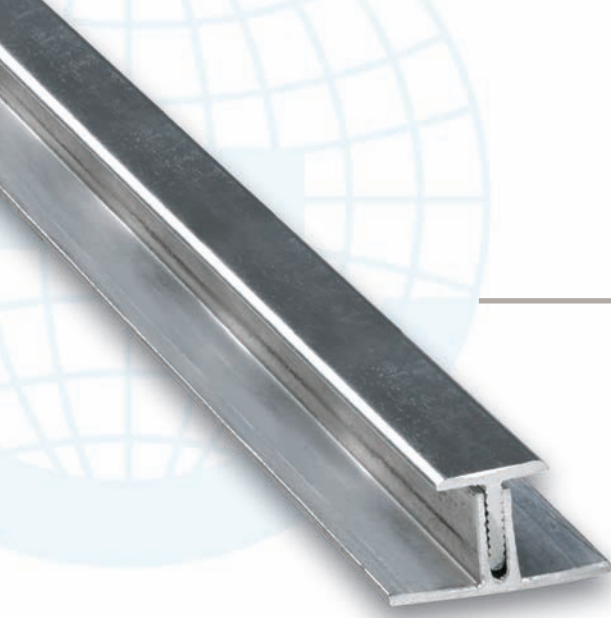

ES EUROLISTELO-247A, listelo de aluminio anodizado formado por dos perfiles. La parte oculta se coloca durante la obra, y una vez finalizada y limpia la zona de trabajo se coloca la parte exterior y visible. De esta manera conseguimos un acabado perfecto siendo imposible que la parte vista del listelo se estropee durante la colocación.

EN EUROLISTELLO-247A, This anodized aluminium profile consists of two profiles. The hidden part is built in during construction work. Once the work is finished and the working area is cleaned, the outward visible part is inserted. This way, a perfect finishing is achieved making it impossible to damage the visible part.



Longitud 2,50 m. Embalaje: 10 u/caja.

Lenght: 8,2 ft. Packing: 10 u/box.

Precio/Price: € /perfil

Referencia Reference	Colores Colours	a: 12 mm 1/2"
247A-PB	Plata brillo	15,13
247A-PM	Plata mate	14,03

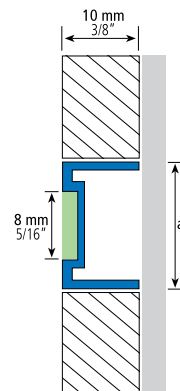
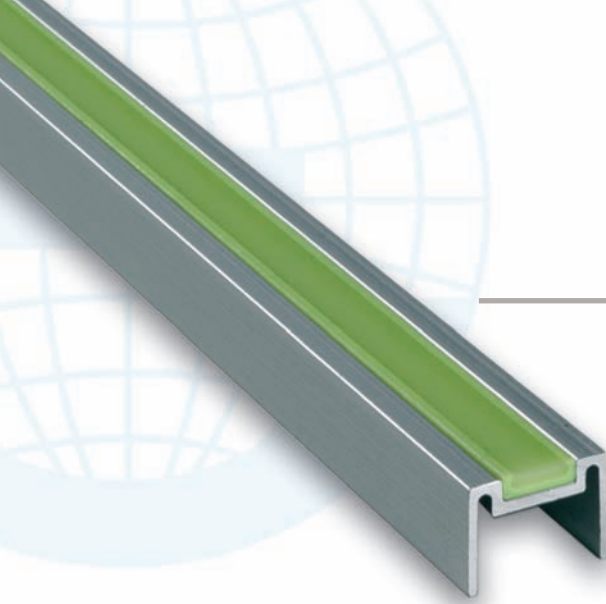

ES EUROLISTELO-250A LUMINOUS, listelo de aluminio con fotoluminiscencia. En la parte vista del perfil se ha colocado una lámina fotoluminiscente para proporcionar visibilidad en ausencia de luz. Según el **Standard Test Method for Photonic Luminance of Photoluminescent ASTM E 2073-07**, al que se ha sometido el producto, nuestro LISTELO es capaz de proporcionar sobre 4 horas y media de visibilidad tras 10 mn de activación a 150 lux. El listelo ha sido diseñado pensando en el marcaje de vías de evacuación o como apoyo lumínico en la oscuridad, facilitando y abaratando el cumplimiento de las normas de seguridad actuales, pudiendo utilizarse tanto en revestimientos como en pavimentos.

EN LUMINOUS EUROLISTELLO-250A, aluminium listello with photoluminescence. A photoluminescent plate has been placed on the visible part of the profile in order to make it visible in dark areas. This LISTELLO has undergone the **Standard Test Method for Photonic Luminance of Photoluminescent ASTM E 2073-07**, which enables it to provide a visibility of around 4 hours and a half after 10 mn of activation at 150 lux. It was designed to mark the evacuation routes or to shed light in the dark and thus making it easier to comply with the current security standards while reducing the cost of this compliance. This listello can be used both in tilings and floorings.

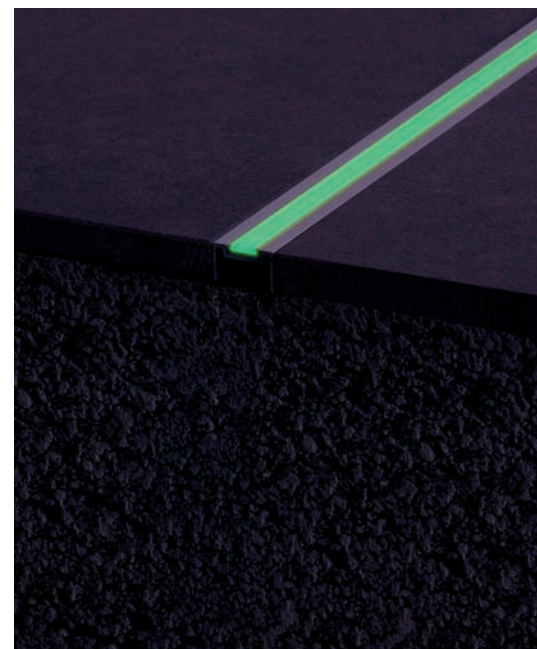
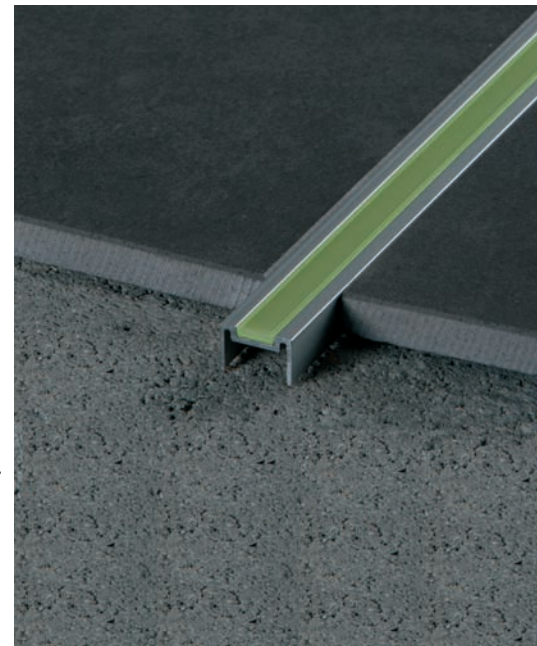

Longitud 2,50 m. Embalaje: 10 u/caja.
Lenght: 8,2 ft. Packing: 10 u/box.

Precio/Price: € /perfil

Referencia Reference	Colores Colours	a: 15,4 mm 9/16"
250A-PM	Plata mate	41,73

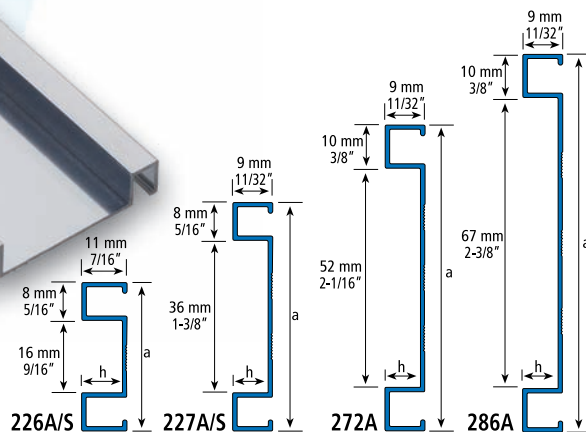

(A) Aluminio/Aluminium
(S) Acero inoxidable / Stainless Steel

ES EUROBASE, Perfil para listelo decorativo que permite la inserción de cerámica o mosaico. La altura interior máxima es de 8 mm, excepto la referencia 226A que admite cerámica de hasta 10 mm. La Eurobase posibilita al cliente la personalización de su listelo, garantizando la exclusividad del producto final.

EN EUROBASE, Profile for decorative listello which allows the insertion of ceramics or mosaic. The maximum interior height is 8 mm except for reference 226A which allows ceramics up to 10 mm. Eurobase enables the customer to personalise his/her listello, ensuring the exclusiveness of the final product.



Aluminio - Longitud 2,50 m. Embalaje: 10 u/caja.
Aluminium - Length: 8,2 ft. Packing: 10 u/box.

Precio/Price: € /perfil

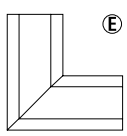
Referencia Reference	Colores Colours	a: 32 mm 1-1/4"	a: 52 mm 2-3/32"	a: 72 mm 2-7/8"	a: 87 mm 3-1/2"
226A-PB	Plata brillo	€ 25,00			
226A-PM	Plata mate	€ 25,00			
226A-OB	Oro brillo	€ 25,00			
226A-NO	Nogal	€ 25,00			
226A-RO	Roble	€ 25,00			
227A-PB	Plata brillo		€ 29,00		
227A-PM	Plata mate		€ 29,00		
227A-OB	Oro brillo		€ 29,00		
272A-PB	Plata brillo			€ 32,00	
286A-PB	Plata brillo				€ 36,00
E-226A	 esquina/corner Blister: 1 u.	8,00			
E-227A			10,00		
E-272A				12,00	
E-286A					13,00

Acero inoxidable - Longitud 2,50 m. Embalaje: 20 u/caja.
Stainless steel - Length: 8,2 ft. Packing: 20 u/box.

226S-IB	Inox brillo	26,00			
227S-IB			30,00		

Gama de color / Colour range. Pag.168 Con film protector / With protective tape. / AISI-304







Con los perfiles para peldaños obtenemos el acabado perfecto para los escalones, embelleciéndolos a la misma vez que proporcionamos seguridad para el usuario y protección para el revestimientos.

With the profiles for steps you can get the perfect finishing for steps. Not only do they look better, but they also provide protection for the covering, as well as safety for users.

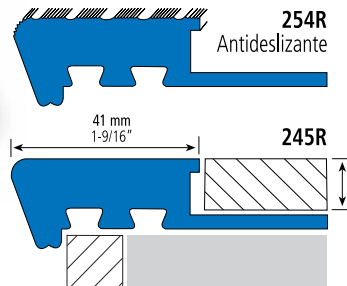
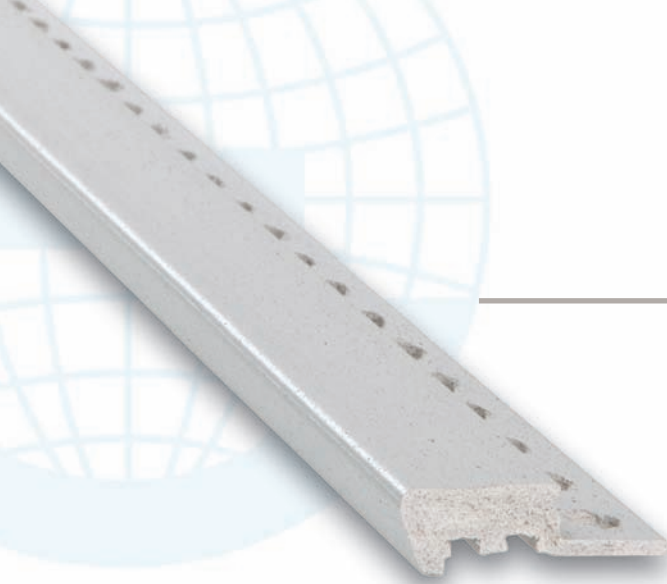

ES EUROPELDAÑO, perfil rústico de PVC + FN para el remate de escalones, con una superficie de pisada de 41 mm. Fabricado con un **PVC especial con fibras naturales recicladas**, gracias a las cuales ofrece un acabado rugoso que se amolda perfectamente a los revestimientos rústicos o no uniformes que se encuentran en el mercado actual. EUROSHRINK apuesta por nuevos componentes que son por supuesto 100% reciclables.

EN EUROSTEP, This rustic profile made of PVC + natural fibres employed for the finishing of steps. It has a footstep surface of 41 mm. Thanks to the production with a special **PVC including natural recycled fibers**, it presents a rough finishing that adjusts perfectly to rustic or uniform tilings which can be found on the current market. EUROSHRINK is increasingly committed to new components that can be recycled entirely.

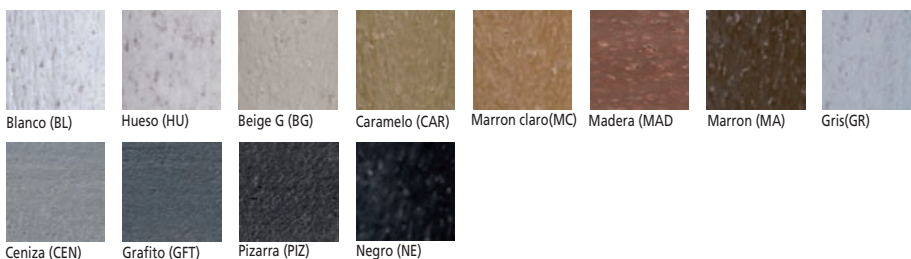
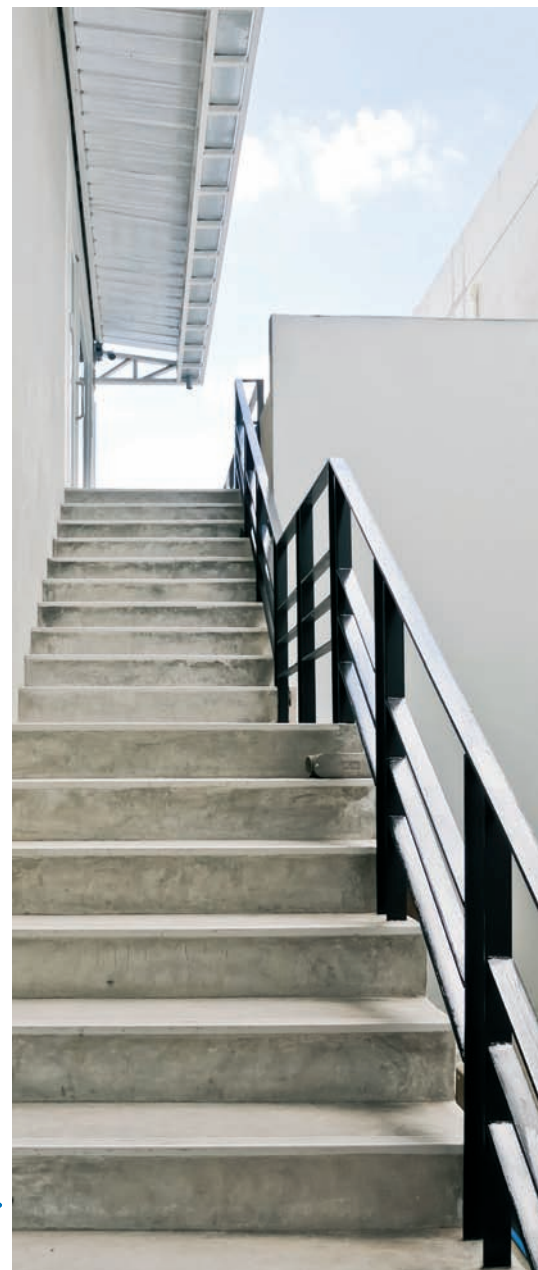

Longitud 2,50 m. Embalaje: 10 u/caja.

Length: 8,20 ft. Packing: 10 u/box.

Precio/Price: € /perfil

Referencia Reference	Colores Colours	Medida Size	L: 1m 3,28 ft.	L: 2,5m 8,2 ft.
245R	Blanco (BL) *Hueso (HU) *Beige G (BG) Caramelo (CAR) Marron claro (MC) Madera (MAD) *Marron (MA) Gris (GR) *Ceniza (CEN) *Grafito (GFT) *Pizarra (PIZ) *Negro (NE)	h: 12,5 mm 1/2"	15,14	30,29
254R Antideslizante		h: 12,5 mm 1/2"	21,54	43,89

* 254R Colores disponibles * 254R Available colours

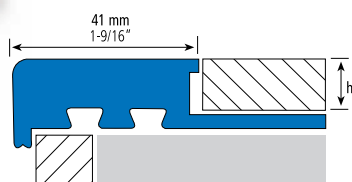
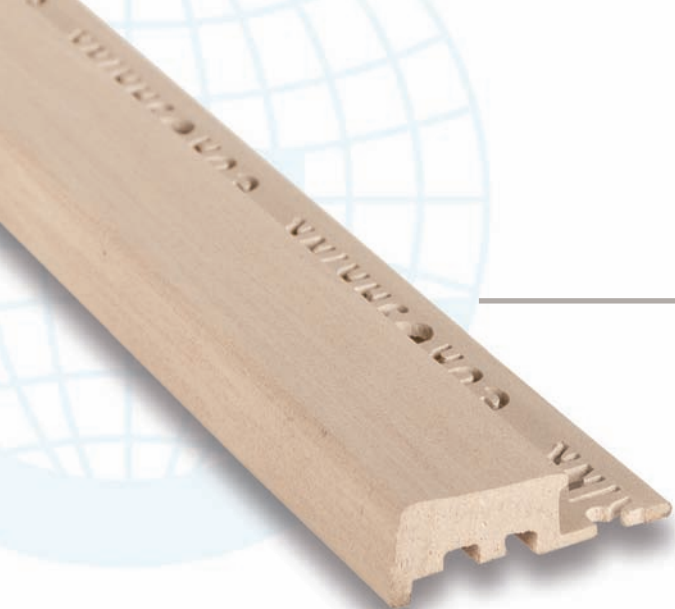

ES EUROPELDAÑO 268R, perfil rústico de PVC + FN de canto recto para el remate de escalones, con una superficie de pisada de 41 mm. Fabricado en PVC especial con fibras naturales recicladas, gracias a las cuáles ofrece un acabado rugoso que se amolda perfectamente a los revestimientos rústicos o no uniformes del mercado. No es recomendable usar esta referencia en exteriores, pues la exposición continuada a los rayos solares podría alterar el color. Para el uso en exteriores se recomienda usar la referencia 268R TEXTURA. EUROSHRINK apuesta por nuevos componentes que son por supuesto 100% reciclables y que contribuyen a la conservación del medio ambiente.

EN EUROSTEP 268R, rustic straight-edge PVC + FN profile for adding a finish to steps with a footfall surface area of 41mm. Manufactured in special PVC with recycled natural fibres, which offers a coarse finish that moulds perfectly to the rustic or non-uniform coatings on the market. We do not recommend using this reference outdoors, as continued exposure to sunlight could change its colour. For use outdoors, we recommend using the reference entitled 268R TEXTUR. EUROSHRINK is committed to new components that are of course 100% recyclable and contribute to preserving the environment.

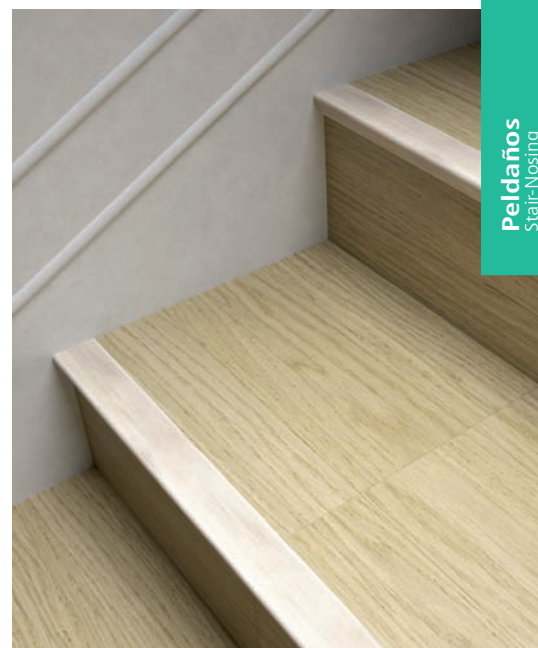

Peldaños
Stair-Nosing

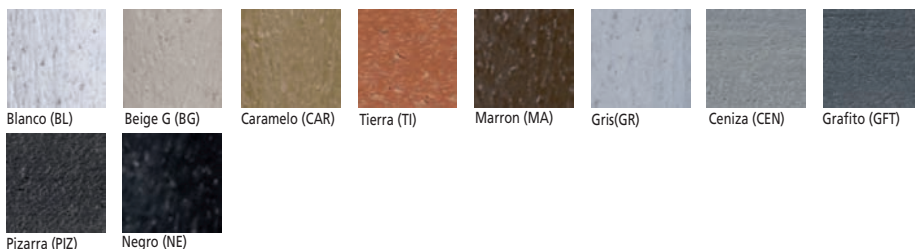

Longitud 2,50 m. Embalaje: 10 u/caja. Length: 8,20 ft. Packing: 10 u/box.

Precio/Price: € /perfil

Referencia Reference	Colores Colours	Medida Size	L: 1m 3,28 ft.	L: 2,5m 8,2 ft.
268R	Blanco (BL) Beige G (BG) Caramelo (CAR) Tierra (TI) Marron (MA) Gris (GR) Ceniza (CEN) Grafito (GFT) Pizarra (PIZ) Negro (NE)	h: 12,5 mm 1/2"	15,69	31,39

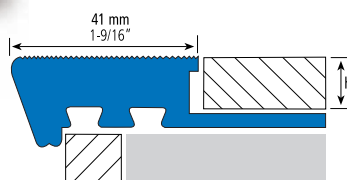

ES EUROPELDAÑO 245R TEXTURA, perfil rústico de PVC + FN para el remate de escalones, con una superficie de pisada de 41 mm. Fabricado con un PVC especial con fibras naturales recicladas, gracias a las cuáles ofrece un acabado rugoso que se amolda perfectamente a los revestimientos rústicos o no uniformes del mercado. Puede ser usado tanto en interior como en exterior. Su superficie estriada proporciona una gran capacidad antideslizante al perfil. EUROSHRINK apuesta por nuevos componentes que son por supuesto 100% reciclables y que contribuyen a la conservación del medio ambiente.

EN EUROSTEP 245R TEXTURA, rustic straight-edge PVC + FN profile for adding a finish to steps with a footfall surface area of 41mm. Manufactured in special PVC with recycled natural fibres, which offers a coarse finish that moulds perfectly to the rustic or non-uniform coatings on the market. It can be used both indoors and outdoors. Its fluted surface provides a great non-slip capacity to the profile. EUROSHRINK is committed to new components that are of course 100% recyclable and contribute to preserving the environment.



TEXTURA
Blanco
(TX/BL)

TEXTURA
Beige G
(TX/BG)

TEXTURA
Marron claro
(TX/MC)

TEXTURA
Ceniza
(TX/CE)

TEXTURA
Pizarra
(TX/PIZ)

TEXTURA
Negro
(TX/NE)

Longitud 2,50 m. Embalaje: 10 u/caja. Lenght: 8,20 ft. Packing: 10 u/box.

Precio/Price: € /perfil

Referencia Reference	Colores Colours	Medida Size	L: 1m 3,28 ft.	L: 2,5m 8,2 ft.
245R TEXTURA	Textura Blanco (TX/BL) Textura BeigeG (TX/BG) Textura Marron claro (TX/MC) Textura Ceniza (TX/CE) Textura Pizarra (TX/PIZ) Textura Negro (TX/NE)	h: 12,5 mm 1/2"	24,20	48,40

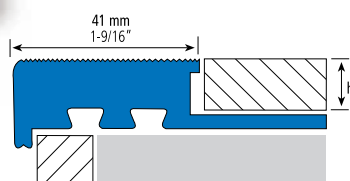
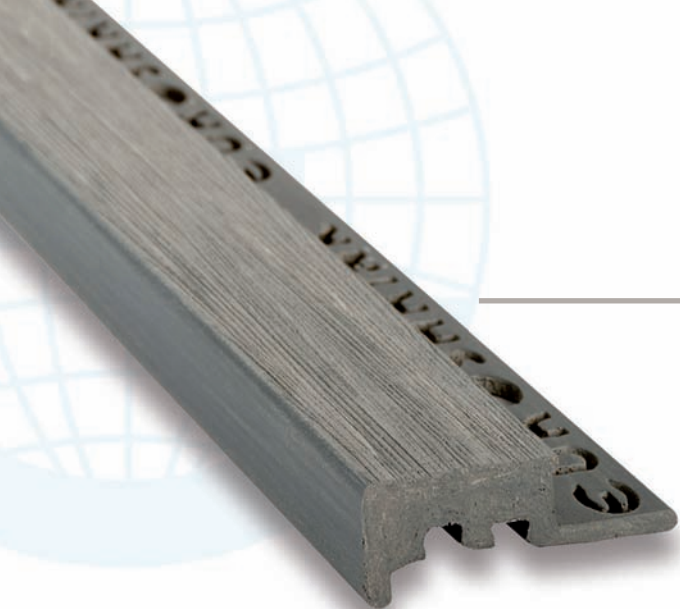

ES EUROPELDAÑO 268R TEXTURA, perfil rústico de PVC + FN de canto recto para el remate de escalones, con una superficie de pisada de 41 mm. Fabricado con un PVC especial con fibras naturales recicladas, gracias a las cuáles ofrece un acabado rugoso que se amolda perfectamente a los revestimientos rústicos o no uniformes del mercado. Puede ser usado tanto en interior como en exterior. Su superficie estriada proporciona una gran capacidad antideslizante al perfil.
EUROSHRINK apuesta por nuevos componentes que son por supuesto 100% reciclables y que contribuyen a la conservación del medio ambiente.

EN EUROSTEP 268R TEXTURA, rustic straight-edge PVC + FN profile for adding a finish to steps with a footfall surface area of 41mm. Manufactured in special PVC with recycled natural fibres, which offers a coarse finish that moulds perfectly to the rustic or non-uniform coatings on the market. It can be used both indoors and outdoors. Its fluted surface provides a great non-slip capacity to the profile.
EUROSHRINK is committed to new components that are of course 100% recyclable and contribute to preserving the environment.



Peldaños
Stair-Nosing



TEXTURA
Blanco
(TX/BL)

TEXTURA
Beige G
(TX/BG)

TEXTURA
Marron claro
(TX/MC)

TEXTURA
Ceniza
(TX/CE)

TEXTURA
Pizarra
(TX/PIZ)

TEXTURA
Negro
(TX/NE)

Longitud 2,50 m. Embalaje: 10 u/caja. Lenght: 8,20 ft. Packing: 10 u/box.

Precio/Price: € /perfil

Referencia Reference	Colores Colours	Medida Size	L: 1m 3,28 ft.	L: 2,5m 8,2 ft.
268R TEXTURA	Textura Blanco (TX/BL) Textura BeigeG (TX/BG) Textura Marron claro (TX/MC) Textura Ceniza (TX/CE) Textura Pizarra (TX/PIZ) Textura Negro (TX/NE)	h: 12,5 mm 1/2"	25,30	50,60

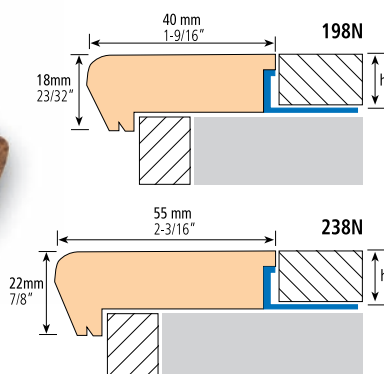

ES EUROPELDAÑO-198/238N, perfil para el remate de escalones, fabricado con dos componentes de gran calidad: madera y aluminio. La parte vista de 40 o 55 mm está fabricada en IROKO, que es una madera tropical de gran resistencia muy apropiada para uso en pavimentos. El aluminio es el componente del perfil mediante el cual se realiza la sujeción a la obra, proporcionando dureza y fiabilidad a largo plazo por su gran resistencia.

EN EUROSTEP-198/238N, profile used to finish off steps, including two high quality components: wood and aluminium. The section shown of 40 or 55 mm is manufactured with IROKO, a tropical kind of wood, which is highly resistant and very suitable for the use on floorings. By means of the component aluminium, the profile is fixed to the building and grants long-term hardness and trustiness, because of its strong resistance.



Embalaje: 10 u/caja.

Packing: 10 u/box.

Precio/Price: €

Referencia Reference	Colores Colours	Medida Size	L: 1 m 3,28 ft	L: 1,20 m 3,94 ft	L: 2,5 m 8,2 ft
198 N	Iroko natural	h: 11 mm 7/16" a: 40 mm 1-9/16"	37,07	39,59	74,15
238 N	Iroko natural	h: 12,5 mm 1/2" a: 55 mm 2-3/16"	52,71	54,60	105,42
238 N	Iroko natural	h: 15 mm 9/16" a: 55 mm 2-3/16"	53,21	55,60	106,42

*La longitud de los perfiles dependerá del stock disponible.
*The length of the profiles will depend of the available stock.



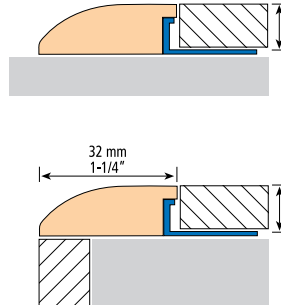

Peldaños
Stair-Nosing

ES EUROPELDAÑO-199N, perfil para el remate de escalones, fabricado con dos componentes de gran calidad: madera y aluminio. La parte vista de 32 mm está fabricada en IROKO, que es una madera tropical de gran resistencia muy apropiada para uso en pavimentos. El aluminio es el componente del perfil mediante el cual se realiza la sujeción a la obra, proporcionando dureza y fiabilidad a largo plazo por su gran resistencia. Debido a la forma especial que posee este escalón, puede perfectamente ser usado como cambio de nivel entre diferentes tipos de pavimentos.

EN EUROSTEP-199N, profile used to finish off steps, including two high quality components: wood and aluminium. The section shown of 32 mm is manufactured with IROKO, a tropical kind of wood, which is highly resistant and very suitable for the use on floorings. By means of the component aluminium, the profile is fixed to the building and grants long-term hardness and trustiness, because of its strong resistance. Due to the special shape of the step, it works perfectly as a level change between different types of floorings



Embalaje: 10 u/caja.
Packing: 10 u/box.

Precio/Price: €

Referencia Reference	Colores Colours	Medida Size	L: 1 m 3,28 ft	L: 1,20 m 3,94 ft	L: 2,5 m 8,2 ft
199 N	Iroko natural	h: 11 mm 7/16"	32,08	34,79	72,41

*La longitud de los perfiles dependerá del stock disponible.
*The length of the profiles will depend of the available stock.

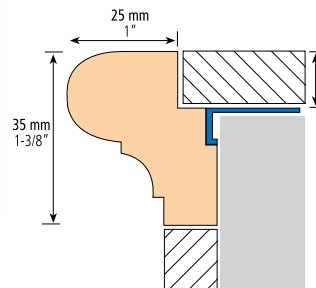

ES EUROPELDAÑO-237N, perfil para el remate de escalones, fabricado con dos componentes de gran calidad: madera y aluminio. En éste EUROPELDAÑO se ha enfatizado su perfil decorativo frontal de 35 mm, frente a la huella de pisada de 25 mm. La parte vista está fabricada en IROKO, que es una madera tropical de gran resistencia muy apropiada para su uso en pavimentos. El aluminio es el componente del perfil mediante el cual se realiza la sujeción a la obra, proporcionando dureza y fiabilidad a largo plazo por su gran resistencia.

EN EUROSTEP-237N, profile used to finish off steps, including two high quality components: wood and aluminium. In this EUROSTEP the forntal decorative profile of 35 mm, has been made to stand out from the 25 mm footprint. The section shown is manufactured with IROKO, a tropical wood, wich is highly resistant and very suitable for the use on flooring. By means of the component aluminium, the profile is fixed to the building and grants long-term hardness and trustiness, because of its strong resistance.



Embalaje: 10 u/caja.
Packing: 10 u/box.

Precio/Price: €

Referencia Reference	Colores Colours	Medida Size	L: 1 m 3,28 ft	L: 1,20 m 3,94 ft	L: 2,5 m 8,2 ft
237 N	Iroko natural	h: 12,5 mm 1/2"	48,44	50,66	97,76

*La longitud de los perfiles dependerá del stock disponible.
*The lenght of the profiles will depend of the available stock.

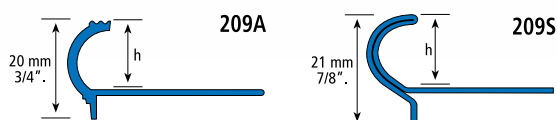
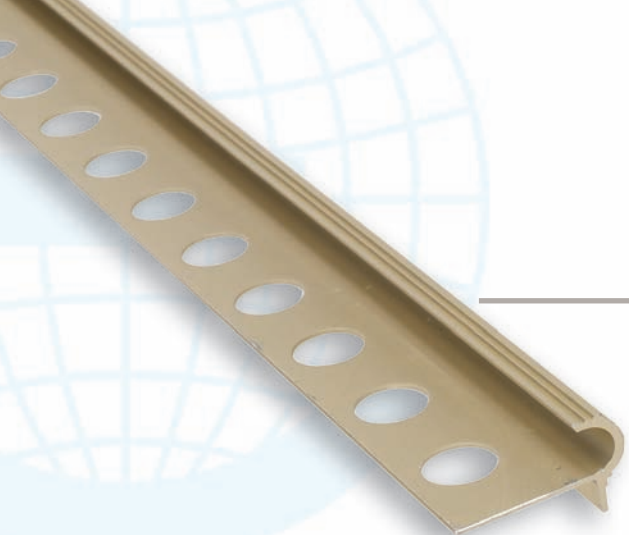

(A) Aluminio/Aluminium (S) Acero inoxidable / Stainless Steel

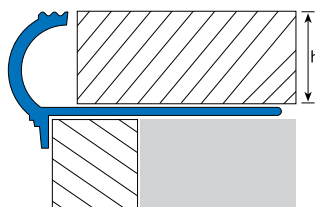

Peldaños
Stair-Nosing

ES EUROPELDAÑO, perfil de canto redondeado para dar mayor seguridad y un acabado más decorativo a los escalones. Remarca el escalón dándole mayor visibilidad y protegiendo el canto del mismo, ya sea este de cerámica, mármol, granito o parquet. El EUROPELDAÑO, se coloca durante la obra.

EN EUROSTEP, rounded profile for steps, to improve safety including an attractive finishing on the steps. It emphasizes the step enhancing its visibility and protecting its edge, regardless if the material is ceramic, marble, granite or parquet. The EUROSTEP is applied during construction work.

Aluminio - Longitud 2,50 m. Embalaje: 10 u/caja.

Aluminium - Length: 8,2 ft. Packing: 10 u/box.

Precio/Price: € /perfil

Referencia Reference	Colores Colours	h: 11 mm 7/16"
209A-PM	Plata mate	14,36
209A-OM	Oro mate	15,86
	F-209A (Tapa final / End cap)	Blister: 1 u.
F-209A-PM	Plata mate	7,30
F-209A-OM	Oro mate	7,30

Acero inoxidable - Longitud 2,50 m. Embalaje: 20 u/caja.

Stainless steel - Length: 8,2 ft. Packing: 20 u/box.

Referencia Reference	Colores Colours	h: 12 mm 1/2"
209S-IB	Inox brillo	32,61
209S-IC	Inox cepillado	32,61
	E-209S (Esquina exterior / Internal corner)	Blister: 1 u.
E-209S-IB	Inox brillo	9,98
E-209S-IC	Inox cepillado	9,98
	F-209S (Tapa final / End cap)	Blister: 1 u.
F-209S-IB	Inox brillo	7,50
F-209S-IC	Inox cepillado	7,50

Con film protector / With protective tape. /AISI-304

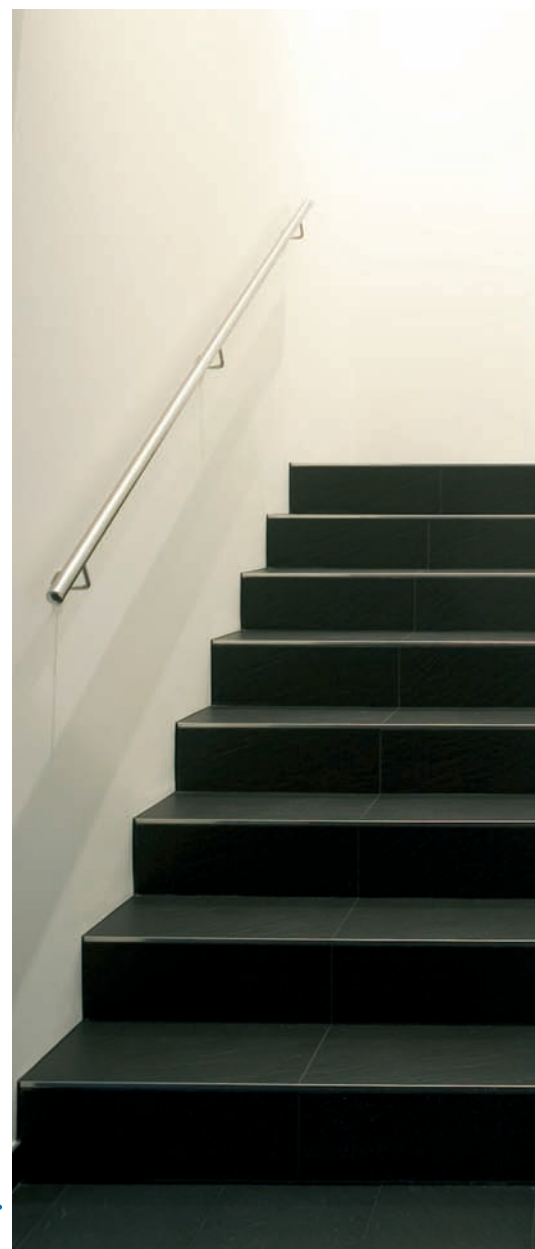

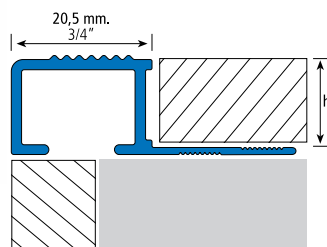
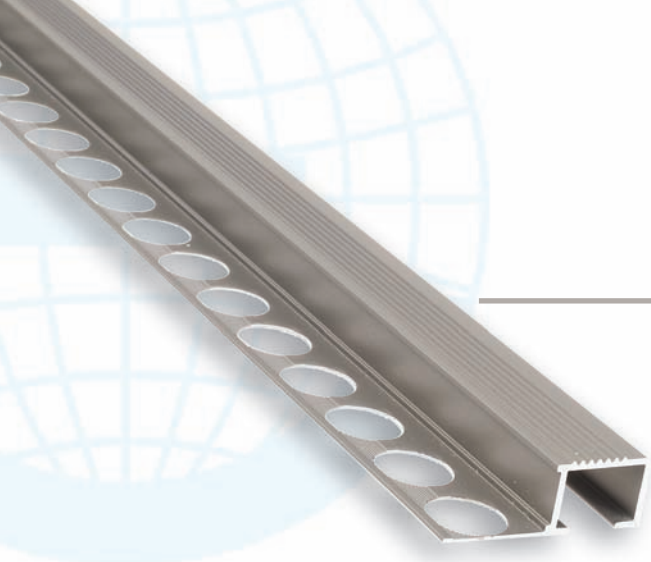

ES EUROPELDAÑO-208A, perfil de aluminio de canto cuadrado para escalones, de una superficie de pisada de 20 mm con ranuras antideslizantes, que proporciona una mayor seguridad y un acabado atractivo a los escalones. Remarca el escalón dándole mayor visibilidad y protegiendo el canto del mismo, ya sea de cerámica, mármol, granito o parquet. El EUROPELDAÑO-208A se coloca durante la obra.

EN EUROSTEP-208A, aluminium profile with a square edge for steps, it has a 20 mm footstep surface with non-slip slots, that enhance safety and give a striking finishing to the steps. It heightens the visibility of the step and also protects its edge, regardless if the material is ceramics, marble, granite or parquet. EUROSTEP-208A is applied during construction work.



Longitud 2,50 m. Embalaje: 10 u/caja.

Lenght: 8,2 ft. Packing: 10 u/box.

Precio/Price: € /perfil

Referencia Reference	Colores Colours	h: 10 mm 3/8"	h: 13 mm 1/2"
208A-PM	Plata mate	20,94	21,04
208A-OM	Oro mate		21,57
208A-BRM	Bronce mate		21,04
 F-208A (Tapa final / End cap)		Blister: 1 u.	
F-208A-PM	Plata mate	7,90	7,90
F-208A-OM	Oro mate		7,90
F-208A-BRM	Bronce mate		7,90

Gama de color / Colour range. Pag.168

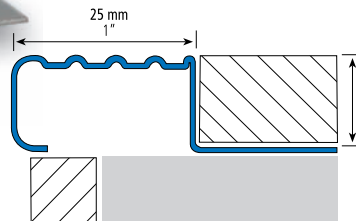
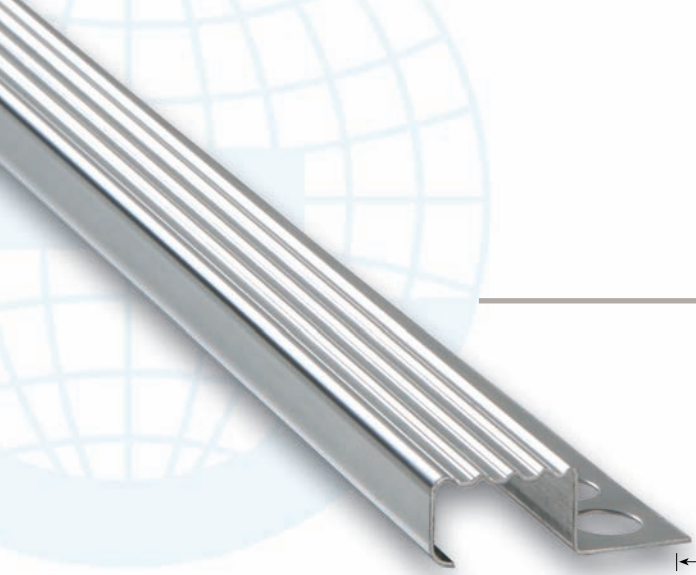

ES EUROPELDAÑO-248S, perfil de acero inoxidable de canto cuadrado para escalones, de una superficie de pisada de 25 mm con ranuras antideslizantes, que proporciona una mayor seguridad y un acabado atractivo a los escalones. Remarca el escalón dándole mayor visibilidad y protegiendo el canto del mismo, ya sea de cerámica, mármol, granito o parquet. El EUROPELDAÑO-248S se coloca durante la obra.

EN EUROSTEP-248S, stainless steel profile with a square edge for steps, it has a 25 mm footstep surface with non-slip slots, that enhance safety and give a striking finishing to the steps. It heightens the visibility of the step and also protects its edge, regardless if the material is ceramics, marble, granite or parquet. EUROSTEP-248S is applied during construction work.

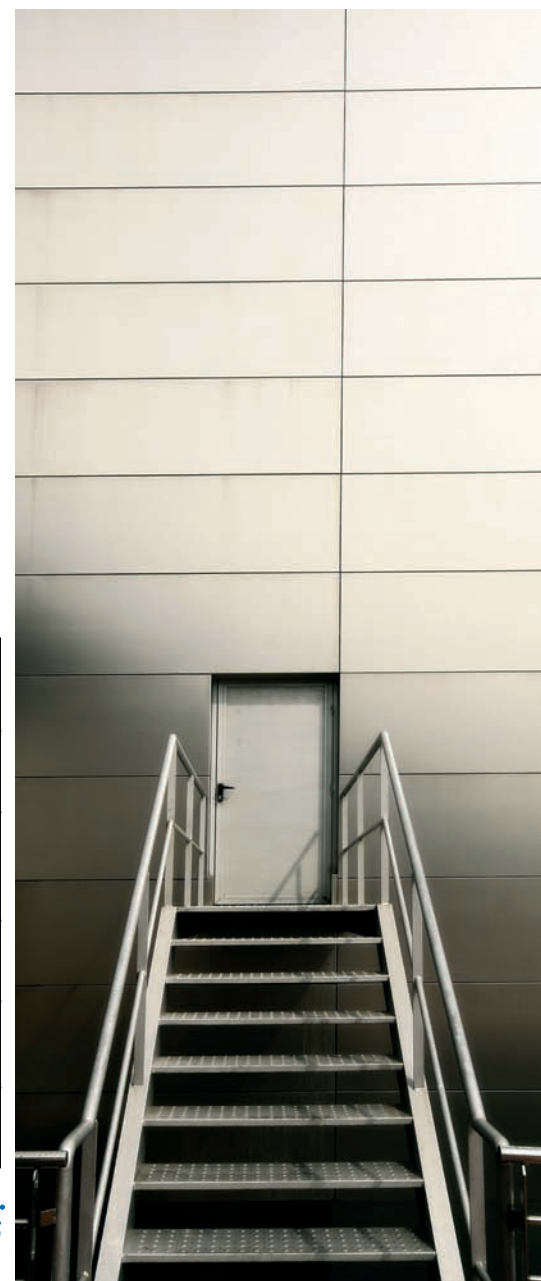

Acero inoxidable - Longitud 2,50 m. Embalaje: 20 u/caja.
Stainless steel - Length: 8,2 ft. Packing: 20 u/box.

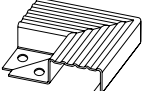
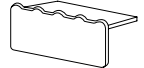
Referencia Reference	Colores Colours	h: 12.5 mm 1/2"
248S-IB	Inox brillo	34,17
248S-IC	Inox cepillado	34,17
 E-248S (Esquina exterior / Internal corner)		Blister: 1 u.
E-248S-IB	Inox brillo	9,98
E-248S-IC	Inox cepillado	9,98
 F-248S (Tapa final / End cap)		Blister: 1 u.
F-248S-IB	Inox brillo	7,50
F-248S-IC	Inox cepillado	7,50

Con film protector / With protective tape. / AISI-304
Gama de color / Colour range. Pag.167

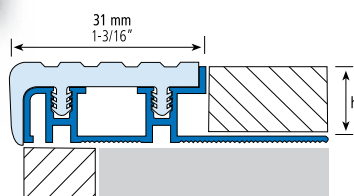
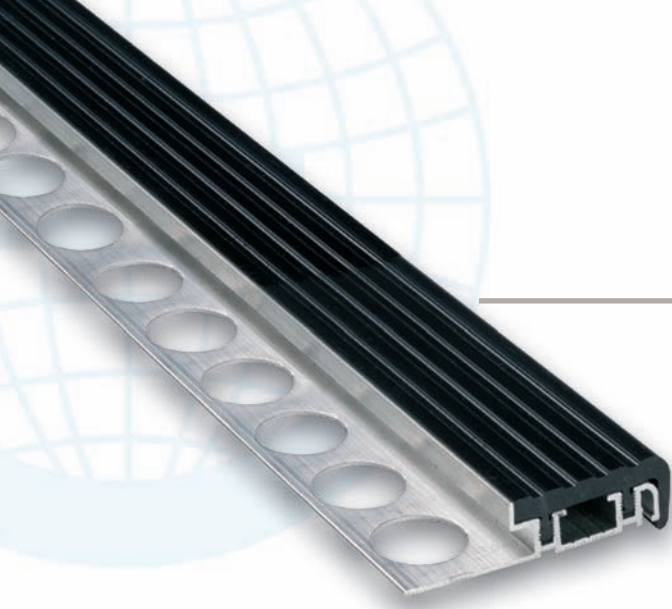

ES EUROPELDAÑO-222A, perfil de aluminio para escalones con una superficie de pisada de 31,5 mm, la parte de PVC, sustituible en caso de deterioro, proporciona una superficie antideslizante y de gran durabilidad en zonas de paso con mucho tránsito. El EUROPELDAÑO remarca el escalón dándole mayor visibilidad y protegiendo el canto del mismo, sea cuál sea el tipo de pavimento. Este perfil se ha de colocar durante el proceso de la obra.

EN EUROSTEP-222A, This aluminium profile for steps has a footstep surface of 31.5 mm. The PVC part can be replaced in case of deterioration and it possesses a durable nonslip surface for busy areas. This profile enhances the visibility of steps and at the same time it protects its edges, regardless of the surface type. It has to be installed during the construction work.

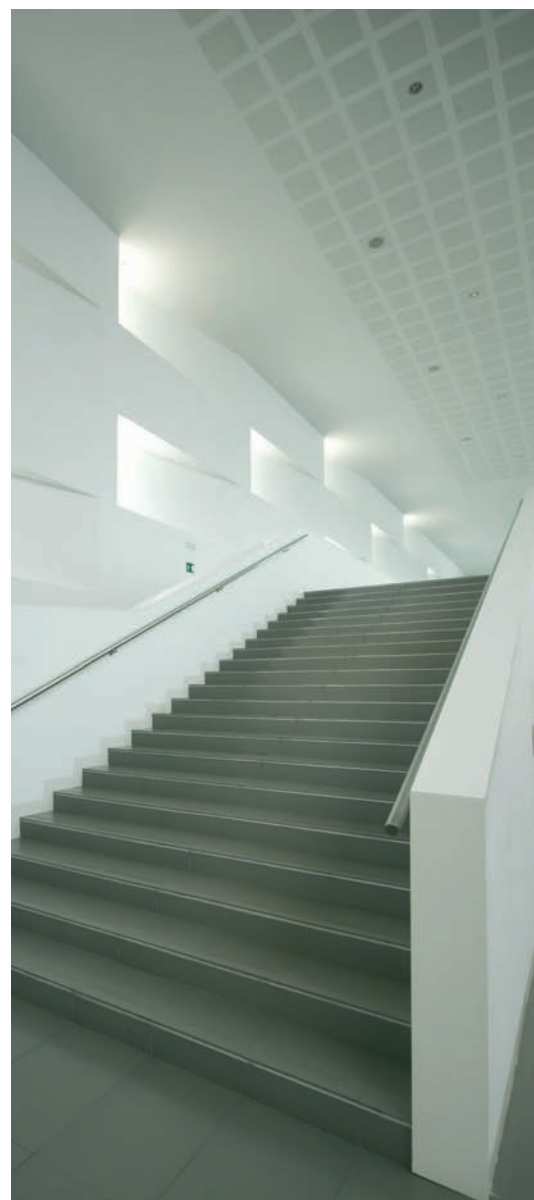

Longitud 2,50 m. Embalaje: 10 u/caja.

Lenght: 8,2 ft. Packing: 10 u/box.

Precio/Price: € /perfil

Referencia Reference	Colores Colours	h: 10 mm 3/8"
222A-GR	Gris	46,75
222A-NE	Negro	46,75

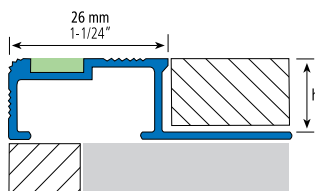
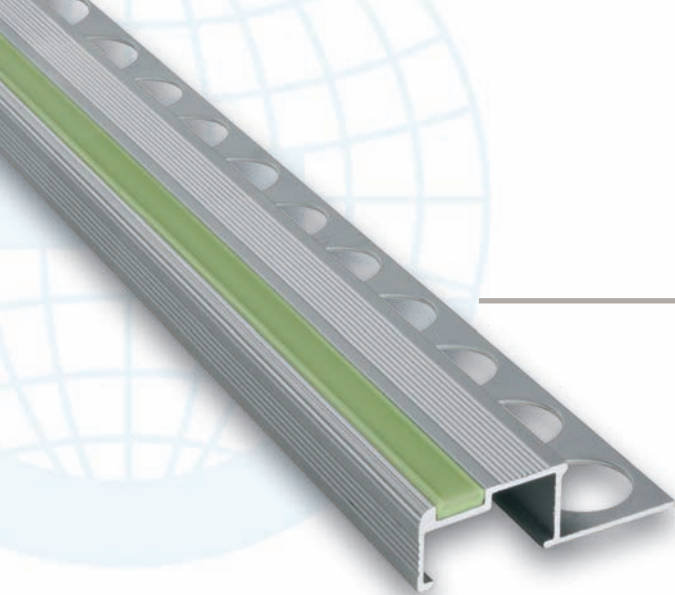

Peldaños
Stair-Nosing

ES EUROPELDAÑO-251A LUMINOUS, perfil de aluminio de canto cuadrado para escalones, de una superficie de pisada de 20 mm con ranuras antideslizantes, que proporciona una mayor seguridad y un acabado atractivo a los escalones. En la parte vista del perfil se ha colocado una lámina fotoluminiscente para proporcionar visibilidad en ausencia de luz. Según el Standard Test Method for Photonic Luminance of Photoluminescent ASTM E 2073-07, al que se ha sometido el producto, nuestro LISTELO es capaz de proporcionar sobre 4 horas y media de visibilidad tras 10 mn de activación a 150 lux. El listelo ha sido diseñado pensando en el marcaje de vías de evacuación o como apoyo lumínico en la oscuridad, facilitando y abaratando el cumplimiento de las normas de seguridad actuales, pudiendo utilizarse tanto en revestimientos como en pavimentos.
El EUROPELDAÑO-251A se coloca durante la obra

EN LUMINOUS EUROSTEP-251A, aluminium profile with a square edge for steps, it has a 20 mm footstep surface with non-slip slots, that enhance safety and give a striking finishing to the steps. A photoluminescent plate has been placed on the visible part of the profile in order to make it visible in dark areas. This LISTELLO has undergone the Standard Test Method for Photonic Luminance of Photoluminescent ASTM E 2073-07, which enables it to provide a visibility of around 4 hours and a half after 10 mn of activation at 150 lux. It was designed to mark the evacuation routes or to shed light in the dark and thus making it easier to comply with the current security standards while reducing the cost of this compliance. This listello can be used both in tilings and floorings.
EUROSTEP-251A is applied during construction work.

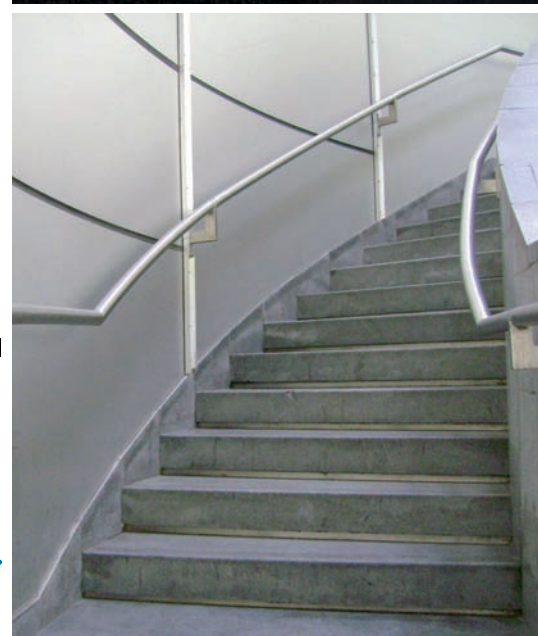
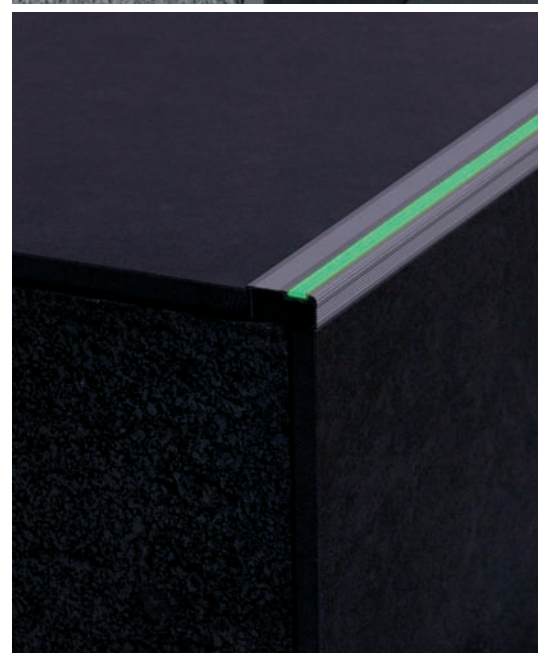

Longitud 2,50 m. Embalaje: 10 u/caja.
Lenght: 8,2 ft. Packing: 10 u/box.

Precio/Price: € /perfil

Referencia Reference	Colores Colours	h: 10,5 mm 3/8"
251A-PM	Plata mate	52,08

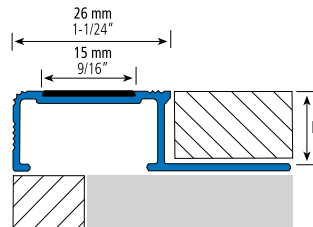
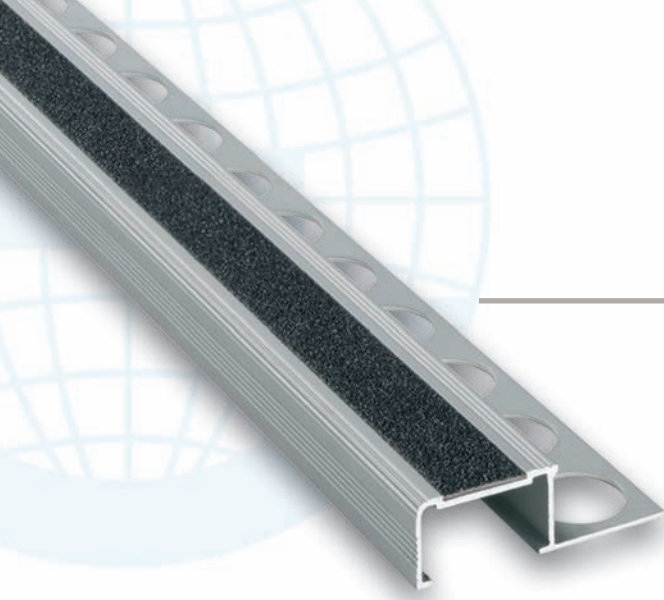

ES EUROPELDAÑO-243A, perfil de aluminio para escalones con una superficie de pisada de 26 mm. En la parte superior se ha insertado una tira antideslizante de gran dureza, por lo que es un perfil de gran utilidad en zonas con mucho tránsito. El Europeldaño proporciona una mayor seguridad junto con un mayor atractivo al escalón al hacerlo más visible. El EUROPELDAÑO-243A se coloca durante el proceso de la obra y puede ser usado indistintamente en interiores o exteriores.

EN EUROSTEP-243A, this aluminium profile possesses a 26 mm footstep surface. A very hard nonslip strip has been inserted in the upper part; therefore it is a very useful profile in busy areas. Due to its visibility, it also enhances the step's safety and appeal. This profile is installed during the construction work and can be used both inside and outside of buildings.



Longitud 2,50 m. Embalaje: 10 u/caja.
Length: 8,2 ft. Packing: 10 u/box.

Precio/Price: € /perfil

Referencia Reference	Colores Colours	h: 12 mm 1/2"
243A-PM	Plata mate	47,85

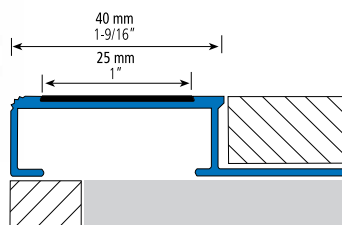
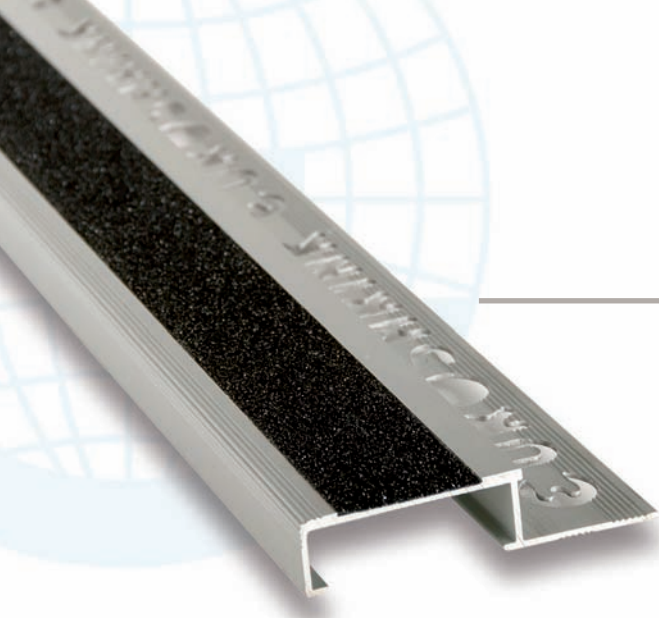

ES EUROPELDAÑO-299A, Perfil de aluminio para escalones con una superficie de pisada de 40 mm y banda antideslizante de gran dureza de 25 mm, que cumple con las normativas de seguridad standard, por lo que es un perfil de gran utilidad en zonas con mucho tránsito. El EUROPELDAÑO-299A, se coloca durante el proceso de la obra y puede ser usado indistintamente en interiores o exteriores. Disponible tapa final, referencia **F-299A**.

EN EUROSTEP-299A, Aluminium profile for steps with a footfall surface area of 40mm and a highly durable non-slip band of 25mm, which complies with the standard safety regulations, making it a very useful profile in areas with a lot of traffic. The EUROPELDAÑO-299A is placed during the work process and can be used interchangeably both indoors or outdoors. End cover available, reference **F-299A**



Peldaños
Stair-Nosing

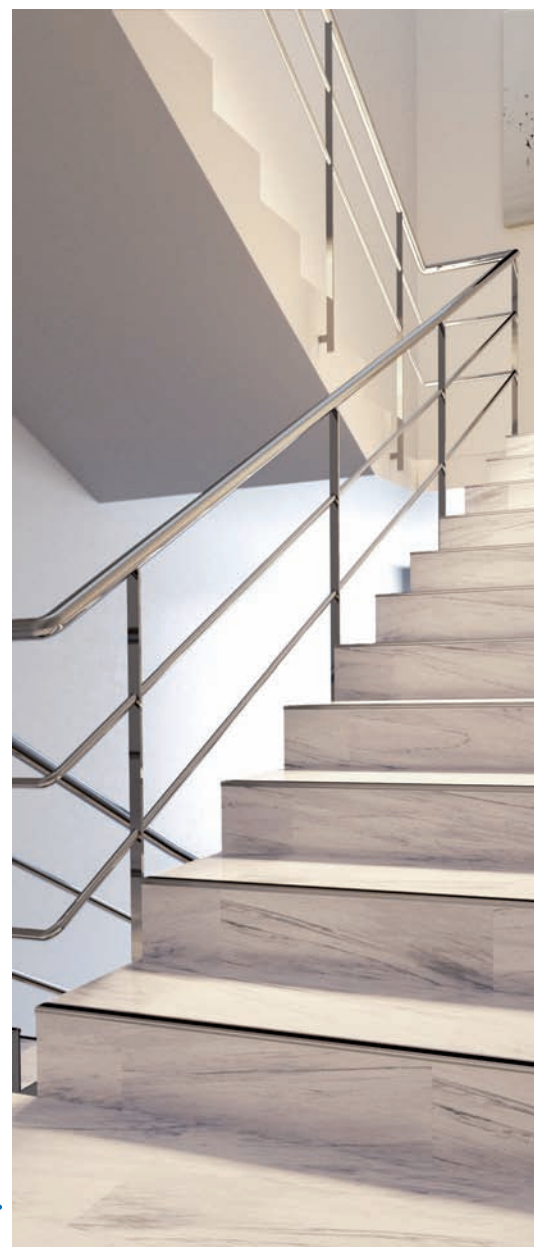

Plata mate/Negro
(PM/NE)



Plata mate/Gris
(PM/GR)



Plata mate/Amarillo
(PM/AM)



Plata mate/Negro-Amarillo
(PM/NA)



Plata mate/Luminoso
(PM/LU)

Longitud 2,50 m. Embalaje: 10 u/caja. Length: 8,2 ft. Packing: 10 u/box.

Precio/Price: € /perfil

Referencia Reference	Colores Colours	h: 12 mm 1/2"
299A-PM/NE	PM/Negro (PM/NE)	55,40
299A-PM/GR	PM/Gris (PM/GR)	55,40
299A-PM/AM	PM/Amarillo (PM/AM)	55,40
299A-PM/NA	PM/Amarillo-Negro (PM/NA)	55,40
299A-PM/LU	PM/Luminoso (PM/LU)	55,40
	F-299A (Tapa final / End cap)	Blister: 1 u.
F-299A-PM	Plata mate	11,03

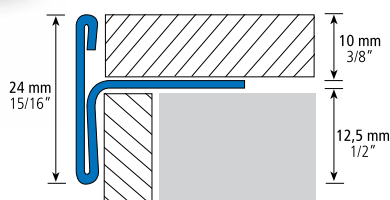
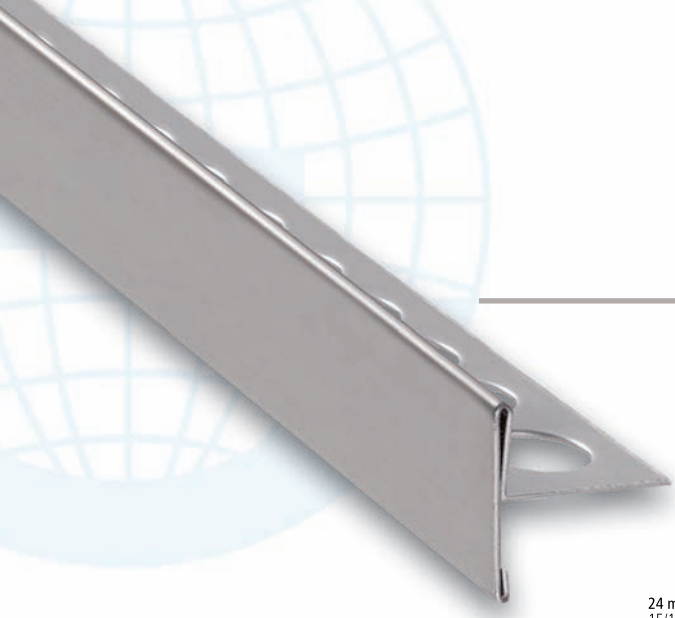

ES EUROPELDAÑO-279S, Perfil decorativo polivalente de acero inoxidable, con vista frontal de 24 mm. Remarca y protege el canto cerámico del escalón. Peldaño reversible adaptable a 10 y 12 mm de altura.

EN EUROSTEP-279S, Multipurpose stainless steel decorative profile whose front view measures 24 mm. It highlights and protects the ceramic edge of the step. Reversible step adaptable at 10 and 12 mm high.

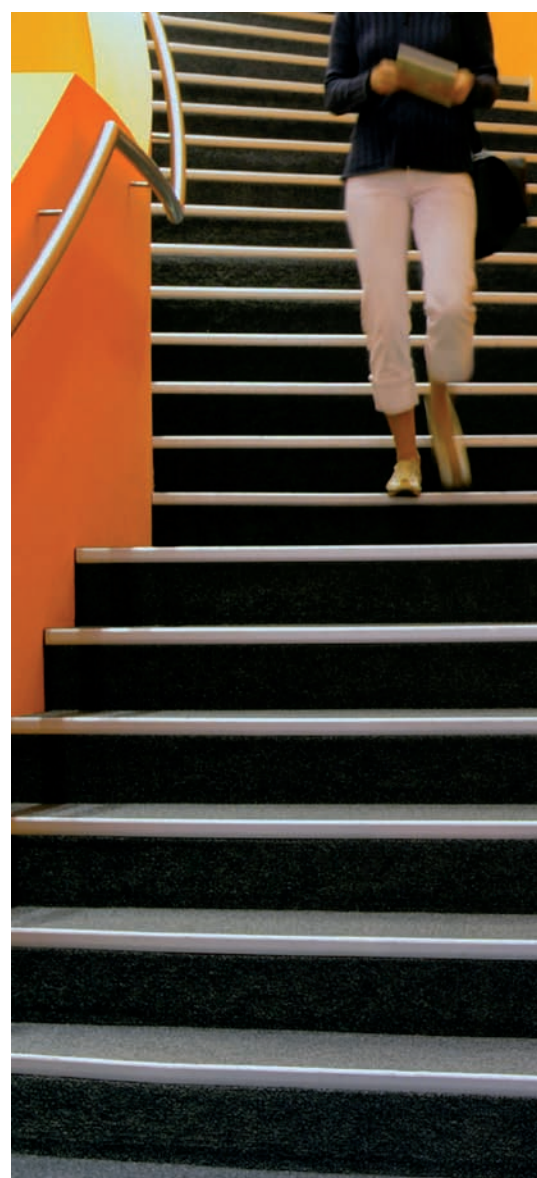

Longitud 2,50 m. Embalaje: 20 u/caja.
Length: 8,2 ft. Packing: 20 u/box.

Precio/Price: € /perfil

Referencia Reference	Colores Colours	h: 10 / 12 mm 1/2"
279S-IB	Inox brillo	24,97

Con film protector / With protective tape. / AISI-304

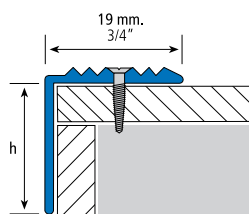
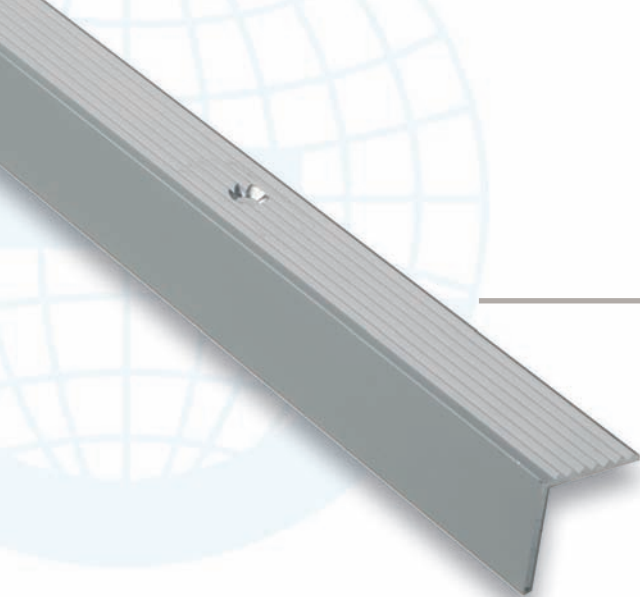

ES EUROPELDAÑO-229A, perfil de aluminio en ángulo recto para escalones, posee una superficie de pisada de 19 mm con ranuras antideslizantes, que proporciona una mayor seguridad y un acabado atractivo a los escalones. Remarca el escalón dándole mayor visibilidad y protegiendo el canto del mismo, ya sea éste de cerámica, mármol, granito o parquet. El EUROPELDAÑO-229A se coloca una vez finalizada la obra, tanto en escalones nuevos para remarcarlos o darles vistosidad, como en reformas de escalones dañados. Este peldaño se fabrica en aluminio anodizado mate para poder ser usado en interiores o exteriores indistintamente.

*El perfil se suministra perforado, con tacos y tornillos, retractilado al completo.

EN EUROSTEP-229A, aluminium profiles in right angle for steps, it has a 19 mm footstep surface, with non-slip slots that provide a greater safety and an eye-catching finishing to the steps. It enhances the visibility of the step and also protects its edge, regardless if the material is ceramic, marble, granite or parquet. EUROSTEP-229A is applied once the construction work has ended, both on new steps and when improving damaged steps in order to emphasize them or make them more striking. This step is produced with matt anodized aluminium that allows it to be employed indoors and outdoors.

*The profile is supplied with drillings, plugs and screws, completely shrink-wrapped in a full package.

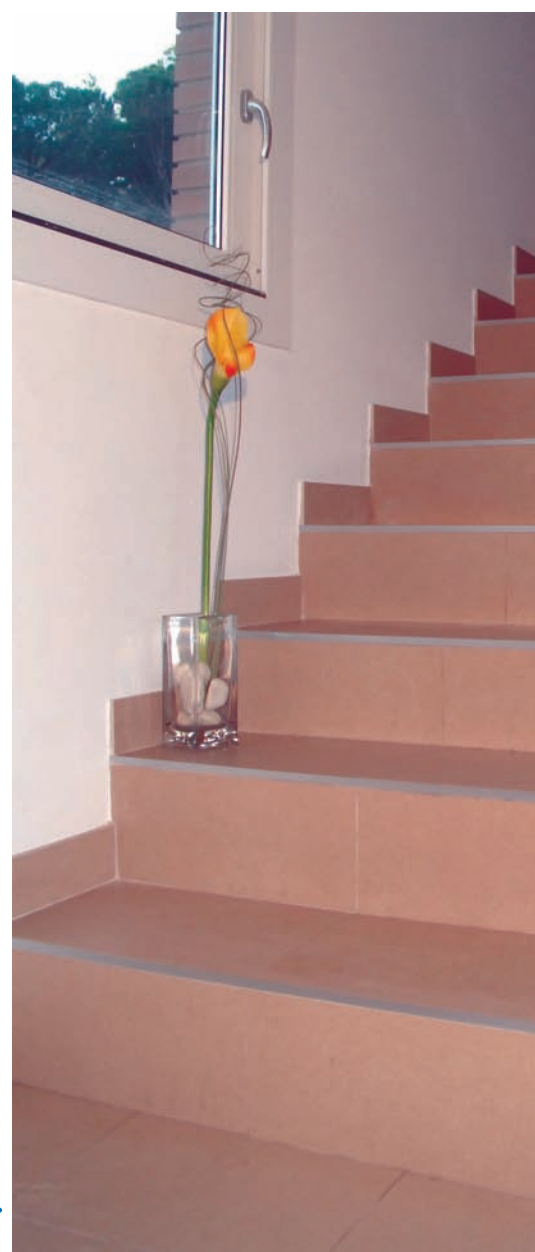

Longitud 2,50 m. Embalaje: 10 u/caja.

Length: 8,2 ft. Packing: 10 u/box.

Precio/Price: € /perfil

Referencia Reference	Colores Colours	h: 18 mm a: 19 mm	23/32" 3/4"
229A-PM	Plata mate		17,46

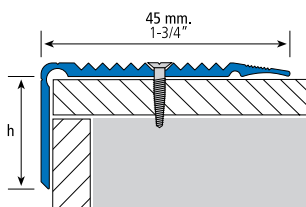
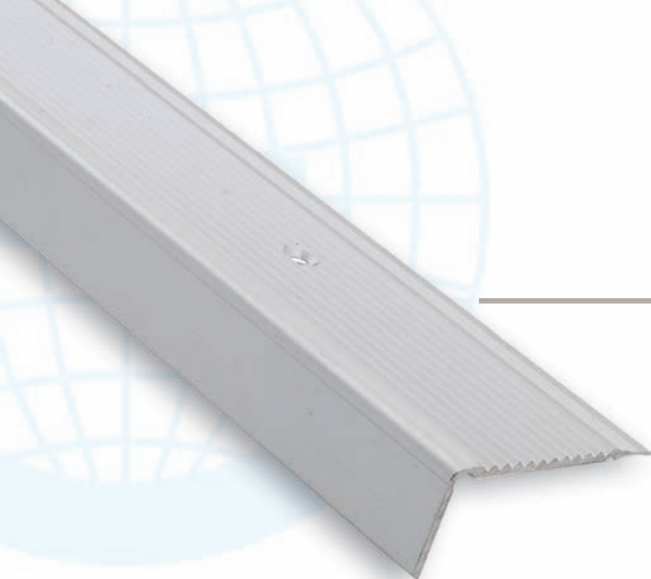

ES EUROPELDAÑO-215A, perfil de aluminio en ángulo recto para escalones, posee una superficie de pisada de 45 mm con ranuras antideslizantes, que proporciona una mayor seguridad y un acabado atractivo a los escalones. Remarca el escalón dándole mayor visibilidad y protegiendo el canto del mismo, ya sea éste de cerámica, mármol, granito o parquet. El EUROPELDAÑO-215A se coloca una vez finalizada la obra, tanto en escalones nuevos para remarcarlos o darles vistosidad, como en reformas de escalones dañados. Este peldaño se fabrica en aluminio anodizado mate para poder ser usado en interiores o exteriores indistintamente.

*215A. El perfil se suministra perforado, con tacos y tornillos, retractilado al completo.

*215A / AD. Autoadhesivo

EN EUROSTEP-215A, aluminium profiles in right angle for steps, it has a 45 mm footstep surface, with non-slip slots that provide a greater safety and an eye-catching finishing to the steps. It enhances the visibility of the step and also protects its edge, regardless if the material is ceramic, marble, granite or parquet. EUROSTEP-215A is applied once the construction work has ended, both on new steps and when improving damaged steps in order to emphasize them or make them more striking. This step is produced with matt anodized aluminium that allows it to be employed indoors and outdoors.

*215A. The profile is supplied with drillings, plugs and screws, completely shrink-wrapped in a full package.

*215A / AD. Self-adhesive



Longitud 2,50 m. Embalaje: 10 u/caja.

Lenght: 8,2 ft. Packing: 10 u/box.

Precio/Price: € /perfil

Referencia Reference	Colores Colours	h: 22 mm a: 45 mm	7/8" 1-3/4"
215A-PM	Plata mate		28,80
215A-OM	Oro mate		34,93
215A-BRM	Bronce mate		30,21

Embalaje: 10 u/caja. h: 22 mm a: 45 mm

Packing: 10 u/box. h: 7/8" a:1-3/4"

Referencia Reference	Colores Colours	L: 1 m 3,28 ft	L: 2,5 m 8,2 ft
215A-PM/AD	Plata mate	14,03	35,05

215A/AD: Autoadhesivo / Self-adhesive

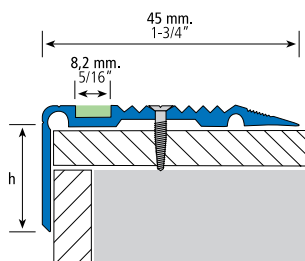
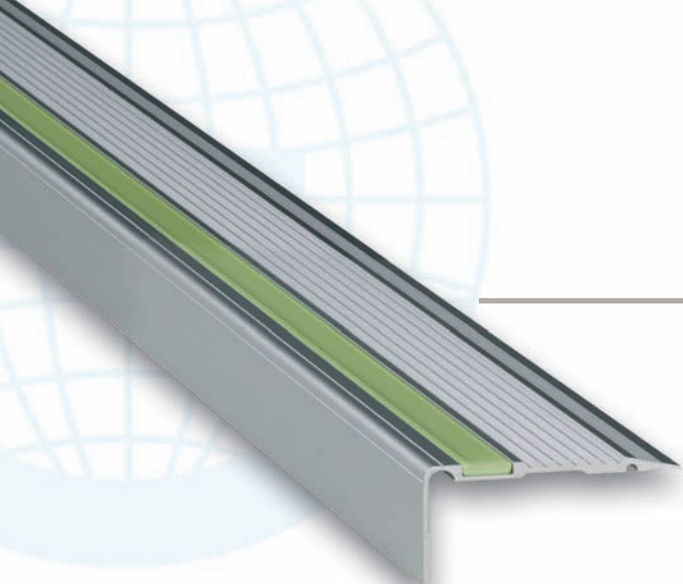

ES EUROPELDAÑO-252A LUMINOUS, perfil de aluminio para el remate de escalones que se coloca una vez finalizada la obra. Posee una superficie de pisada de 45 mm con ranuras antideslizantes para proporcionar mayor seguridad. Remarca el escalón dándole mayor visibilidad y protegiendo el canto del mismo. En la parte externa superior se ha añadido una lámina fotoluminiscente para obtener visibilidad en la oscuridad. Según el Standard Test Method for Photonic Luminance of Photoluminescent ASTM E 2073-07, al que se ha sometido el producto, nuestro PELDAÑO es capaz de proporcionar sobre 4 horas y media de visibilidad tras 10 mn de activación a 150 lux. El peldaño ha sido diseñado pensando en el marcaje de vías de evacuación o como apoyo lumínico en la oscuridad, facilitando y abaratando el cumplimiento de las normas de seguridad actuales.

*El perfil se suministra perforado, con tacos y tornillos, retractilado al completo.

EN LUMINOUS EUROSTEP-252A. This aluminium profile is used to finish off steps and is placed once the construction work is over. Its footstep surface measures 45 mm and it possesses nonslip slots which enhance their safety. A photoluminescent plate has been placed on the top part in order to make the profile visible in dark areas. This STEP has undergone the Standard Test Method for Photonic Luminance of Photoluminescent ASTM E 2073-07, which enables it to provide a visibility of around 4 hours and a half after 10 mn of activation at 150 lux. It was designed to mark the evacuation routes or to shed light in the dark and thus making it easier to comply with the current security standards while reducing the cost of this compliance.

*The profile is supplied with drillings, plugs and screws, completely shrink-wrapped in a full package.

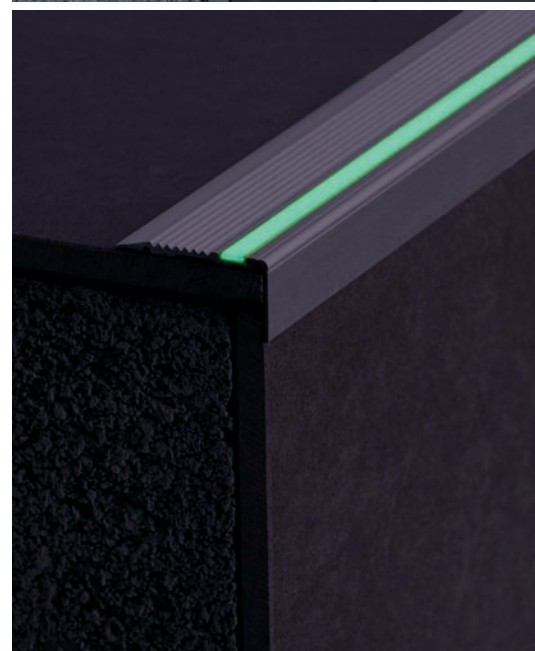

Longitud 2,50 m. Embalaje: 10 u/caja.

Length: 8,2 ft. Packing: 10 u/box.

Precio/Price: € /perfil

Referencia Reference	Colores Colours	h: 22 mm 7/8"	a: 45 mm 1-3/4"
252A-PM	Plata mate		57,29

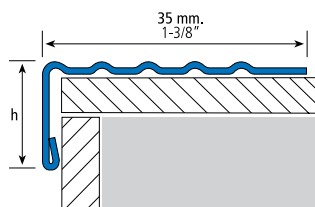
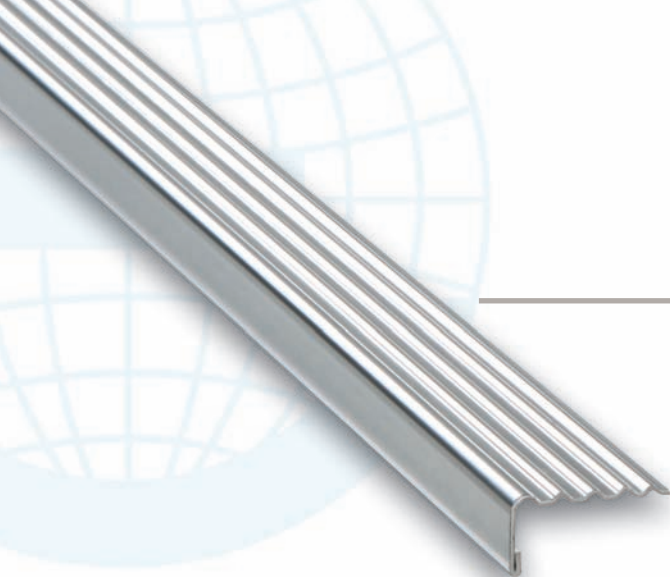

ES EUROPELDAÑO-215S, perfil de acero inoxidable autoadhesivo de canto cuadrado para escalones, de una superficie de pisada de 35 mm con ranuras antideslizantes, que proporciona una mayor seguridad y un acabado atractivo a los escalones. Remarca el escalón dándole mayor visibilidad y protegiendo el canto del mismo, ya sea de cerámica, mármol, granito o parquet.

El Europeldaño-215S se coloca una vez finalizada la obra mediante las tiras adhesivas incorporadas en el interior del perfil, tanto para escalones nuevos como para la reforma de escalones en mal estado.

EN EUROSTEP-215S, Stainless steel and self-adhesive profile with square corners for steps with a 35mm tread surface and slip-proof slots, which provide more safety and a more attractive appearance of steps. Any kind of step, be it ceramic, marble, granite or parquet, is more visible, and its edges are protected.

This product is applied after the construction work by means of adhesive strips which are found in the inner part of the profiles, and can be used both for new and renewable steps.



Embalaje: 20 u/caja. h: 13 mm a: 35 mm

Packing: 20 u/box. h: 1/2" a: 1-3/8"

Precio/Price: € /perfil

Referencia Reference	Colores Colours	L: 1 m 3,28 ft	L: 2,5 m 8,2 ft
215S-IB/AD	Inox brillo	17,27	34,17

215S/AD: Autoadhesivo / Self-adhesive

Con film protector / With protective tape. / AISI-304

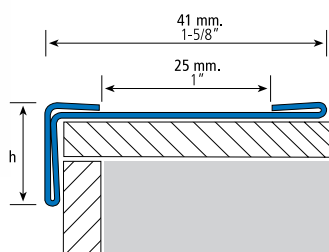
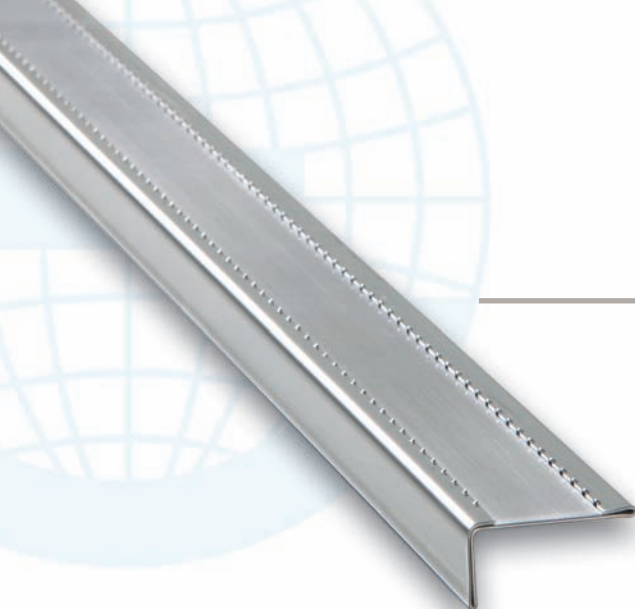

ES EUROPELDAÑO-260S, perfil autoadhesivo de acero inoxidable de canto cuadrado para escalones. La superficie de pisada antideslizante de 41 mm, dónde se combinan el acabado brillo con el cepillado, proporciona una mayor seguridad y un acabado atractivo a los escalones. El Europeldaño-260S remarca el escalón dándole mayor visibilidad y protegiendo el canto del mismo, ya sea de cerámica, mármol, granito o parquet. Recomendado especialmente para zonas de gran tránsito como aeropuertos, grandes almacenes, etc.
El Europeldaño-260S se coloca una vez finalizada la obra mediante las tiras adhesivas incorporadas en el interior del perfil, tanto para escalones nuevos como para la reforma de escalones en mal estado.

EN EUROSTEP-260S, These self-adhesive stainless steel profiles for steps possess square corners and are to be used for steps. The 41mm slip-proof tread surface combines a shiny finishing with brushing, and provides greater safety and an attractive appearance. The profiles also highlight and protect the steps' edges, whether ceramic, marble, granite or parquet. They are highly recommended for intensely stressed areas such as airports, department stores, and so on. This product is applied after the construction work by means of adhesive strips which are found in the inner part of the profiles, and can be used both for new and renewable steps.



Peldaños
Stair-Nosing



Embalaje: 20 u/caja. h: 14 mm a: 41 mm

Packing: 20 u/box. h: 9/16" a: 1-5/8"

Precio/Price: € /perfil

Referencia Reference	Colores Colours	L: 1 m 3,28 ft	L: 2,5 m 8,2 ft
260S-IB+IC/AD	Inox brillo y cepillado	21,74	41,81

260S/AD: Autoadhesivo / Self-adhesive

Con film protector / Whit protective tape. / AISI-304

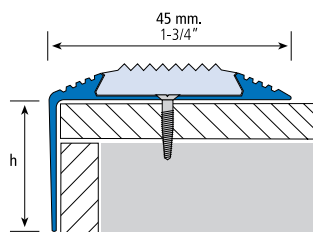
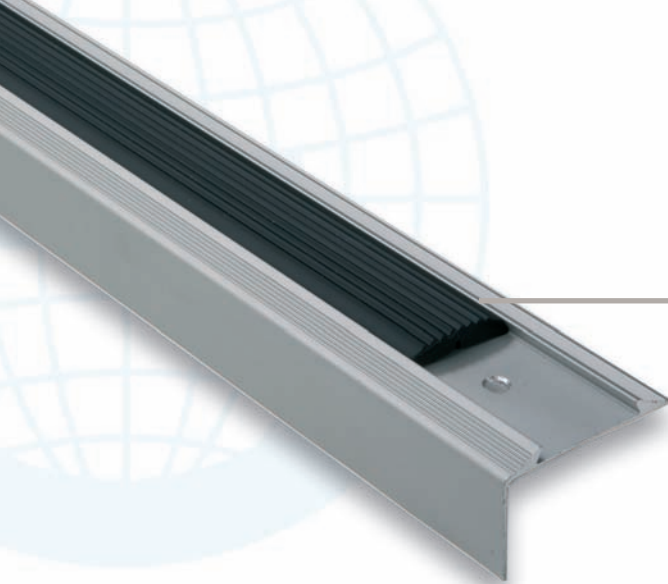

ES EUROPELDAÑO-231A, perfil de aluminio en ángulo recto para escalones con una superficie de pisada de 45 mm. La parte central de PVC extraíble proporciona un escalón antideslizante y totalmente estético, pues oculta los tornillos que fijan el perfil al escalón. Remarca el escalón dándole mayor visibilidad y protegiendo el canto del mismo ya sea de cerámica, mármol, granito o parquet. El EUROPELDAÑO-231A se coloca una vez finalizada la obra, tanto en escalones nuevos para remarcarlos o darles vistosidad, como en reformas de escalones dañados. Este peldaño se fabrica en aluminio anodizado mate para poder ser usado en interiores o exteriores indistintamente.

*El perfil se suministra perforado, con tacos y tornillos, retractilado al completo.

EN EUROSTEP-231A, aluminium profile made in a right angle for steps, with a footstep surface of 45 mm. The central removable PVC part turns the step into a nonslip surface, while not doing any harm to the aesthetics, as it hides the screws that attach the profile to the step. It enhances the visibility of the step and also protects its edge, regardless is the material is ceramic, marble, granite or parquet. EUROSTEP-231A is applied once the construction work has ended, both on new steps and when improving damaged steps in order to emphasize them or make them more striking. This step is produced with matt anodized aluminium that allows it to be employed indoors and outdoors.

* The profile is supplied with drillings, plugs and screws, completely shrink-wrapped in a full package.

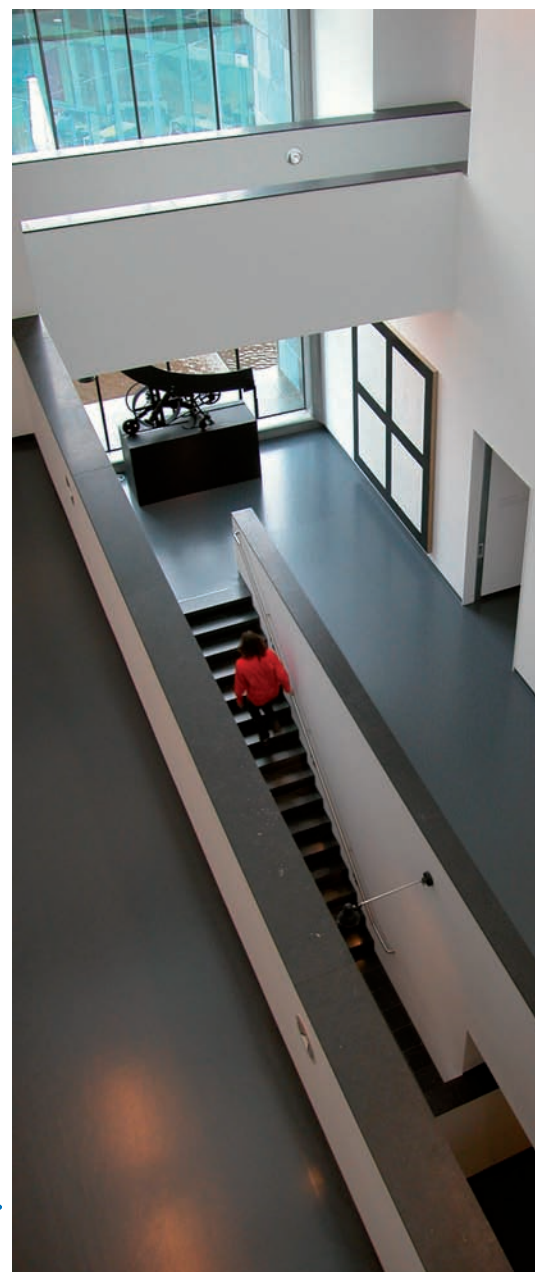

Longitud 2,50 m. Embalaje: 10 u/caja.

Lenght: 8,2 ft. Packing: 10 u/box.

Precio/Price: € /perfil

Referencia Reference	Colores Colours	h: 25 mm a: 45 mm	1" 1-3/4"
231A-PM	Plata mate		37,31

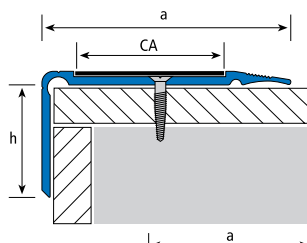
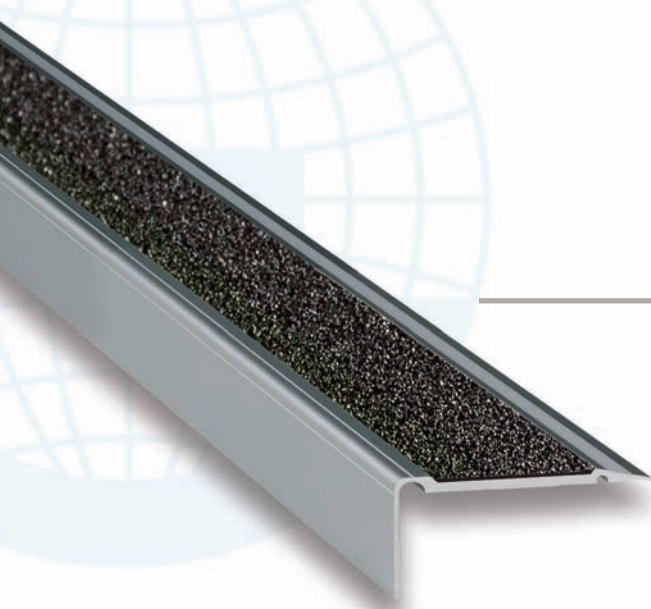

CA (Cinta antideslizante / Anti-slip tape)

ES EUROPELDAÑO-298A, Perfil de aluminio para escalones con superficie de pisada de 45 mm o 65 mm. En la parte superior, el perfil tiene una hendidura donde se ha de colocar nuestra referencia CA, cinta antideslizante de gran dureza. Se recomienda colocarla una vez fijado el perfil al pavimento, de esta manera los tornillos de fijación quedarán ocultos. Se coloca una vez finalizada la obra y puede ser utilizado tanto en interiores como exteriores, para señalar y proporcionar seguridad en escalones o en zonas de mucho tránsito. El perfil se suministra perforado, con tacos y tornillos.

EN EUROSTEP-298A, Aluminium profile for steps with a footfall surface area of 45mm or 65mm. In the upper part, the profile has a groove where you can place our CA reference, a highly durable non-slip band. We recommend placing this once the profile has been fixed to the pavement, so as to conceal the fixing screws. It is placed once the work is complete, and can be used both indoors and outdoors to signpost and provide security to stairways or areas with a lot of traffic. The profile is supplied perforated, with studs and screws.



Peldaños
Stair-Nosing



Longitud 2,50 m. Embalaje: 10 u/caja.

Lenght: 8,2 ft. Packing: 10 u/box.

Precio/Price: € /perfil





Ref. Ref.	Colores Colours	Ancho (a) Width (a)	Altura (h) Height (h)	Longitud Lenght	Precios Price
298A-PM-45 Aluminio <u>CA-25 mm</u>	Plata mate Matt silver	45 mm 1- 3/4"	22 mm 7/8"	2,5 m. 8,2 ft.	35,50
298A-PM-65 Aluminio <u>CA-40 mm</u>	Plata mate Matt silver	65 mm 2- 9/16"	33 mm 1-5/16"	2,5 m. 8,2 ft.	39,70

CA (Cinta antideslizante / Anti-slip tape) ! (Se suministra por separado / Supplied separately) Pag.88				Long. 5m Lenght 5m	Long. 18m Lenght 18m
CANE 25	NEGRO / BLACK	25 mm		5,50	18,50
CANE 40		40 mm		11,60	28,50
CAGR 25	GRIS / GREY	25 mm		8,33	23,70
CAGR 40		40 mm		13,82	36,19
CAAM 25	AMARILLO / YELLOW	25 mm		8,33	23,70
CAAM 40		40 mm		13,82	36,19
CANE-AM 25	NEGRO & AMARILLO BLACK & YELLOW	25 mm		9,32	25,50
CANE-AM 40		40 mm		15,90	39,88
CALU 25	LUMINOSO LUMINOUS	25 mm		15,80	50,34

*Se recomienda colocación por separado para que los tornillos queden ocultos
*It is recommended to be placed separately so that the screws are hidden

Perfil 298A+CA / Profile 298A+CA

Precio/Price: € /perfil

Colores Colours	Ref. Ref.	Ancho (a) Width (a)	Longitud Lenght	U. / Caja U. / Box	Precios Price
	298A-PM/NE-45 298A-PM/NE-65	45 mm 65 mm	2,5m	10	59,50 62,50
	298A-PM/GR-45 298A-PM/GR-65	45 mm 65 mm	2,5m	10	59,50 62,50
	298A-PM/AM-45 298A-PM/AM-65	45 mm 65 mm	2,5m	10	59,50 62,50
	298A-PM/NA-45 298A-PM/NA-65	45 mm 65 mm	2,5m	10	59,50 62,50
	298A-PM/LU-45	45 mm	2,5m	10	59,50

*Suministrado perfil montado 298A+CA / Supplied assembled profile 298A+CA

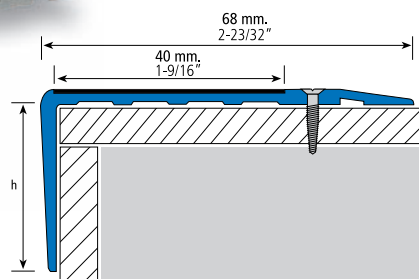

ES EUROPELDAÑO-236A, perfil de aluminio en ángulo recto para escalones con una superficie de pisada de 68 mm. El EUROPELDAÑO-236A viene perforado para facilitar su colocación y posee una parte antideslizante de 40 mm. Remarca el escalón dándole mayor visibilidad y protegiendo el canto del mismo ya sea de cerámica, mármol, granito o parquet. El EUROPELDAÑO-236A se coloca una vez finalizada la obra, tanto en escalones nuevos para remarcarlos o darles vistosidad, como en reformas de escalones dañados. Este peldaño se fabrica en aluminio anodizado mate para poder ser usado en interiores o exteriores indistintamente.

* El perfil se suministra perforado, con tacos y tornillos, retráctilado al completo.

EN EUROSTEP-236A, aluminium profile made in a right angle for steps, with a footstep surface of 68 mm. The EUROSTEP-236A is perforated to facilitate its placement and possesses a non-slip part of 40 mm. It enhances the visibility of the step and also protects its edge, regardless is the material is ceramic, marble, granite or parquet. The EUROSTEP is applied once the construction work has ended, both on new steps and when improving damaged steps in order to emphasize them or make them more striking. This step is produced with matt anodized aluminium that allows it to be employed indoors and outdoors.

* The profile is supplied with drillings, plugs and screws, completely shrink-wrapped in a full package.

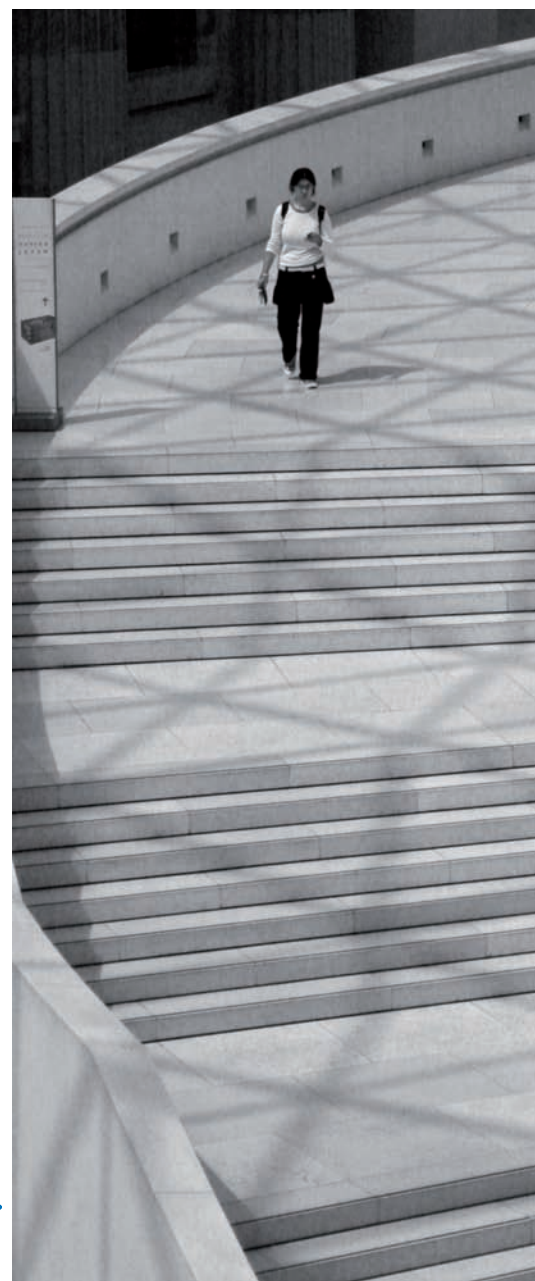

Longitud 2,50 m. Embalaje: 10 u/caja.

Length: 8,2 ft. Packing: 10 u/box.

Precio/Price: € /perfil

Referencia Reference	Colores Colours	h: 30 mm a: 68 mm	1-3/16" 2-23/32"
236A-PM	Plata mate		83,02

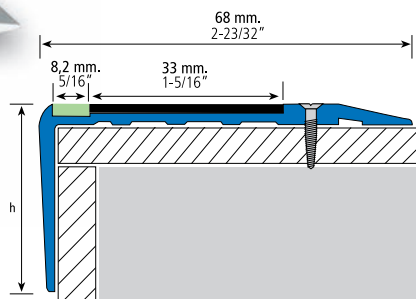

ES EUROPELDAÑO-253A LUMINOUS, perfil de aluminio con una superficie de pisada de 68 mm. El EUROPELDAÑO que posee una parte antideslizante de 33 mm se coloca una vez finalizada la obra, y puede ser utilizado tanto en exteriores como interiores. En la parte externa superior se ha añadido una lámina fotoluminiscente para obtener visibilidad en la oscuridad. Según el Standard Test Method for Photonic Luminance of Photoluminescent ASTM E 2073-07, al que se ha sometido el producto, nuestro PELDAÑO es capaz de proporcionar sobre 4 horas y media de visibilidad tras 10 mn de activación a 150 lux. El peldaño ha sido diseñado pensando en el marcaje de vías de evacuación o como apoyo lumínico en la oscuridad, facilitando y abaratando el cumplimiento de las normas de seguridad actuales.
*El perfil se suministra perforado, con tacos y tornillos, retractilado al completo.

EN LUMINOUS EUROSTEP-253A, this aluminium profile with a footstep surface of 68 mm includes a nonslip part of 33 mm. It is installed once the construction work has finished, and it can be used both inside and outside of buildings. A photoluminescent plate has been placed on the top part in order to make the profile visible in dark areas. This STEP has undergone the Standard Test Method for Photonic Luminance of Photoluminescent ASTM E 2073-07, which enables it to provide a visibility of around 4 hours and a half after 10 mn of activation at 150 lux. It was designed to mark the evacuation routes or to shed light in the dark and thus making it easier to comply with the current security standards while reducing the cost of this compliance.

*The profile is supplied with drillings, plugs and screws, completely shrink-wrapped in a full package.

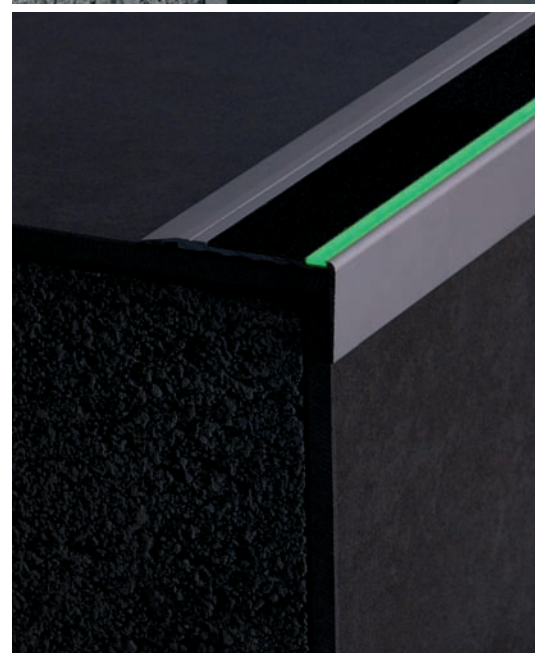

Longitud 2,50 m. Embalaje: 10 u/caja.

Lenght: 8,2 ft. Packing: 10 u/box.

Precio/Price: € /perfil

Referencia Reference	Colores Colours	h: 30 mm a: 68 mm	1-5/16" 2-23/32"
253A-PM	Plata mate		107,84

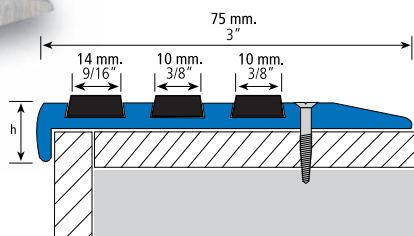
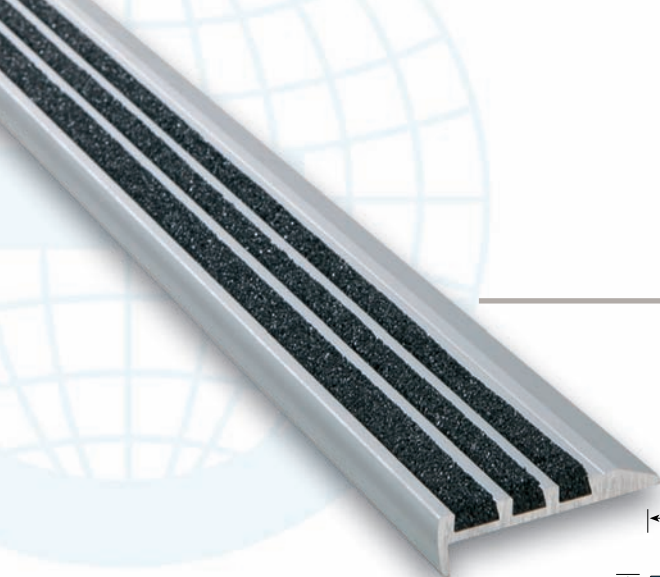

ES EUROPELDAÑO-264A, perfil de aluminio en ángulo recto para escalones con una superficie de pisada de 75 mm. En la misma se encuentran integradas tres líneas de un granulado mineral (Carburo de Silicio) altamente antideslizante hasta en las condiciones más adversas, proporcionando un agarre óptimo y un tránsito seguro. Recomendado especialmente para zonas de gran tránsito como aeropuertos, grandes almacenes, vdas públicas, instalaciones de ocio/tiempo libre, etc.

El Europeldaño-264A viene perforado para facilitar su colocación una vez finalizada la obra, tanto en escalones nuevos para remarcarlos o darles vistosidad, como en reformas de escalones dañados. Este peldaño se fabrica en aluminio anodizado mate para poder ser usado en interiores o exteriores indistintamente.

* El perfil se suministra perforado, con tacos y tornillos, retráctilado al completo.

EN EUROSTEP-264A, Right-angle aluminium profile for steps with a 75mm tread surface and three lines made of slip-proof mineral granules (silicon carbide) which guarantee an optimal grip and tread resistance. They are highly recommendable for intensely stressed areas such as airports, department stores, public thoroughfares, recreational facilities, and others.

This product is drilled in order to make them easier to use after construction works on new steps that need to be highlighted or for the renovation of damaged steps. These steps are produced with matt anodized aluminium which make them usable for inner and outer spaces without distinction.

* It is supplied with drillings, screws and plugs, and completely shrink-wrapped in a full package.



Longitud 2,50 m. Embalaje: 10 u/caja.

Lenght: 8,2 ft. Packing: 10 u/box.

Precio/Price: € /perfil

Referencia Reference	Colores Colours	h: 12 mm
264A-PM	Plata mate	176,55

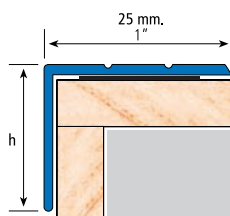

(AD) Autoadhesivo / self adhesive

ES EUROPELDAÑO-295A, Perfil de aluminio autoadhesivo en ángulo recto con una superficie de pisada de 25 mm, para escalones de parquet o pavimento. El Europeldaño se presenta en aluminio anodizado o en acabado decorativo de madera (lámina de PVC resistente a los productos habituales de limpieza no abrasivos). Se suministra con tiras adhesivas para su colocación inmediata.

EN EUROSTEP-295A, Self-adhesive aluminium profile at right-angle with a 25 mm flooring surface for flooring or parquet steps. The Eurostep is made of anodised aluminium or a decorative wooden finish (PVC sheet resistant to the usual non-abrasive cleaning products). It is supplied with adhesive strips for immediate laying.



Peldaños
Stair-Nosing



Roble Claro (RC)



Roble Natural (RN)



Haya (HA)



Roble (RO)



Cerezo (CE)



Sapelly (SA)



Nogal Satinado (NS)



Nogal (NO)



Madera Gris Claro (MGC)



Madera Gris (MG)

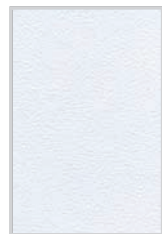

Blanco 2 (BL2)



Plata Mate (PM)



Oro Mate (OM)

Referencia	Colores	Altura (h)	Longitud	€/ m.	Unidades / Caja	
Referencia	Colours	Height (h)	Lenght		Units / Box	
295A/AD Aluminio 295A/AD Aluminium	Blanco 2	White 2	20 mm 3/4"	1 m. 3,28 ft.	11,75	10
	Plata mate	Matt silver				
	Oro mate	Matt gold				
	Roble Claro	Light Oak				
	Roble Natural	Natural Oak				
	Haya	Beech				
	Roble	Oak				
	Cerezo	Cherry				
	Sapelly	Sapelly				
	Nogal Satinado	Satin Walnut				
	Nogal	Walnut				
	Madera G. Claro	Light Grey Wood				
	Madera Gris	Grey Wood				

(AD) Autoadhesivo / Self-adhesive

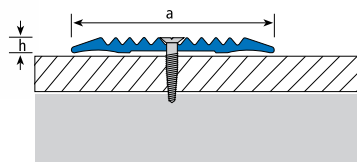
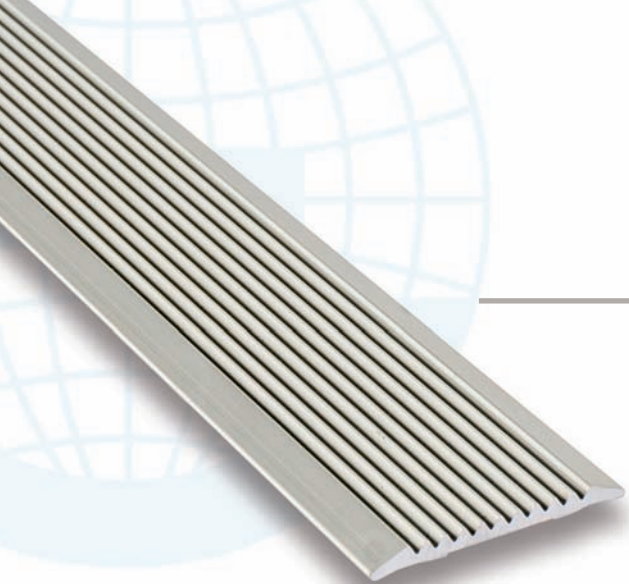

ES EUROLETINA-296A, Europletina de aluminio para zonas en las que sea importante incrementar la seguridad contra caídas, resbalones, ... Posee una superficie de pisada de 35 mm con ranuras antideslizantes que le confieren seguridad y visibilidad al escalón, la rampa o la zona de tránsito en el que se instale. La EUROLETINA 296A se coloca una vez finalizada la obra y está fabricado en aluminio mate anodizado para ser usado tanto en interiores como exteriores.
*La EUROLETINA 296A se suministra perforada , con tacos y tornillos, retractilada al completo.

EN EUROFLAT-296A, The aluminium EUROFLAT is for areas that require elevated safety measures against falls, slips, etc. It has 35-mm tread surface with anti-slip slots, providing the safety and visibility for the step, ramp, or transit area in the installation site. The EUROFLAT 296A is installed when work has finished and is manufactured with matte anodised aluminium that can be used both inside and outside.

*The EUROFLAT 296A is supplied with perforations, plugs, and screws, fully shrink-wrapped.



Longitud 2,50 m. Embalaje: 10 u/caja.

Lenght: 8,2 ft. Packing: 10 u/box.

Precio/Price: € /perfil

Referencia Reference	Colores Colours	a: 35 mm h: 2,5 mm	1-3/8" 3/32"
296A-PM	Plata mate		23,59

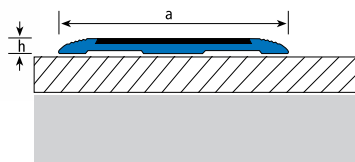
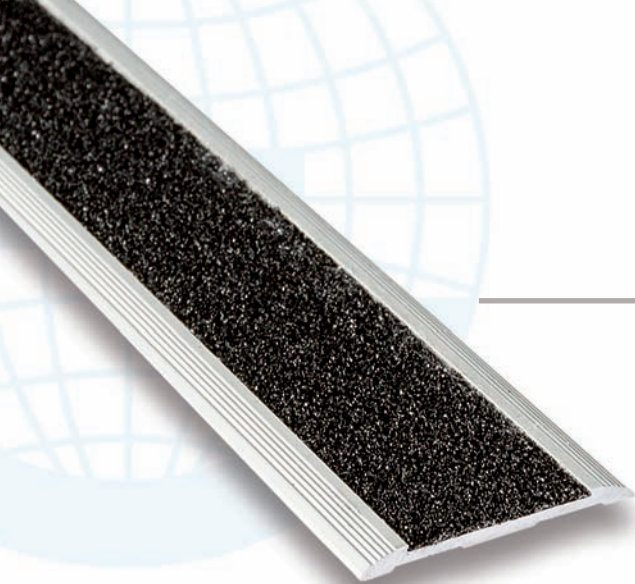

(AD) Autoadhesivo /self adhesive

ES EUROPLETINA-297A, Perfil de aluminio autoadhesivo con superficie de pisada de 38 mm y banda antideslizante de 25 mm, que cumple con las normativas de seguridad standard. Se coloca una vez finalizada la obra y puede ser utilizada tanto en interiores como exteriores para señalar y proporcionar seguridad en escalones, zonas de alto tránsito peatonal o rampas.

EN EUROFLAT-297A, Self-adhesive aluminium profile with 38-mm tread surface and a 25-mm anti-slip band, complying with standard safety regulations. It is installed when work has finished and can be used both inside and outside to mark and provide safety for steps, pedestrian transit areas, or ramps.



Longitud 2,50 m. Embalaje: 10 u/caja.
Lenght: 8,2 ft. Packing: 10 u/box.

Precio/Price: € /perfil

Referencia Reference	Colores Colours	a: 38 mm h: 2,5 mm	1-1/2" 3/32"
297A-PM / NE	Plata mate/Negro		42,55

(AD) Autoadhesivo / Self-adhesive





UROCINTA ANTIDESLIZANTE

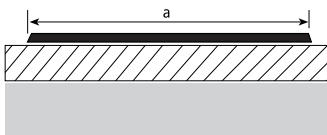

ES EUROCINTA-CA, Cinta antideslizante autoadhesiva para suelos tanto de interior como de exterior. Duradera y de fácil aplicación, evita caídas en escaleras, rampas o cualquier superficie resbaladiza.

EN EUROTAPE-CA, Self-adhesive anti-slip tape for indoor and outdoor floors. Durable and easy to apply, avoid falls on stairs, ramps or any other slippery surface.

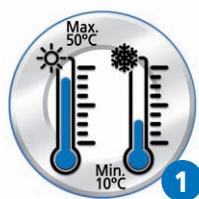
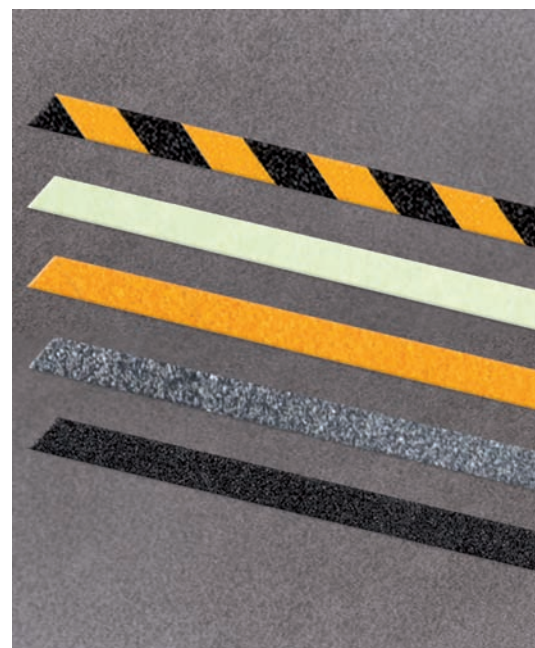

Embalaje: 10 u/caja (Longitud 18m) - 20 u/caja (Longitud 5m)

Packing: 10 u/box (Lenght 59,05 ft) - 20 u/box (Lenght 16,40 ft)

Colores Colours	Ref. Ref.	Ancho (a) Wide (a)	Longitud Lenght	Precio/Price: €/u.
NEGRO / BLACK	CANE 25/5	25 mm / 1"	5 m / 16,40 ft	5,50
	CANE 25/18	25 mm / 1"	18 m / 59,05 ft	18,50
	CANE 40/5	40 mm / 1-9/16"	5 m / 16,40 ft	11,60
	CANE 40/18	40 mm / 1-9/16"	18 m / 59,05 ft	28,50
GRIS / GREY	CAGR 25/5	25 mm / 1"	5 m / 16,40 ft	8,33
	CAGR 25/18	25 mm / 1"	18 m / 59,05 ft	23,70
	CAGR 40/5	40 mm / 1-9/16"	5 m / 16,40 ft	13,82
	CAGR 40/18	40 mm / 1-9/16"	18 m / 59,05 ft	36,19
AMARILLO / YELLOW	CAAM 25/5	25 mm / 1"	5 m / 16,40 ft	8,33
	CAAM 25/18	25 mm / 1"	18 m / 59,05 ft	23,70
	CAAM 40/5	40 mm / 1-9/16"	5 m / 16,40 ft	13,82
	CAAM 40/18	40 mm / 1-9/16"	18 m / 59,05 ft	36,19
NEGRO & AMARILLO BLACK & YELLOW	CANE-AM 25/5	25 mm / 1"	5 m / 16,40 ft	9,32
	CANE-AM 25/18	25 mm / 1"	18 m / 59,05 ft	25,50
	CANE-AM 40/5	40 mm / 1-9/16"	5 m / 16,40 ft	15,90
	CANE-AM 40/18	40 mm / 1-9/16"	18 m / 59,05 ft	39,88
LUMINOSO / LUMINOUS	CALU 25/5	25 mm / 1"	5 m / 16,40 ft	15,80
	CALU 25/18	25 mm / 1"	18 m / 59,05 ft	50,34





Las transiciones de Euroshrink son el acabado perfecto para salvar un desnivel entre diferentes materiales, o para separar y remarcar pavimentos. Con la amplia gama de transiciones que ofrecemos, encontrará la solución que necesita obteniendo un acabado perfecto y elegante.

Our profiles for transitions are the best solution when dealing with unevenness due to the use of different materials or when used for separating and highlighting different floorings. Our big product range offers you a perfect and elegant solution for your transition areas.

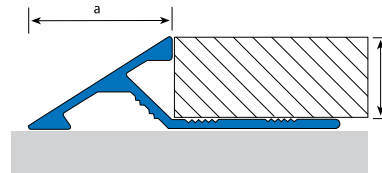
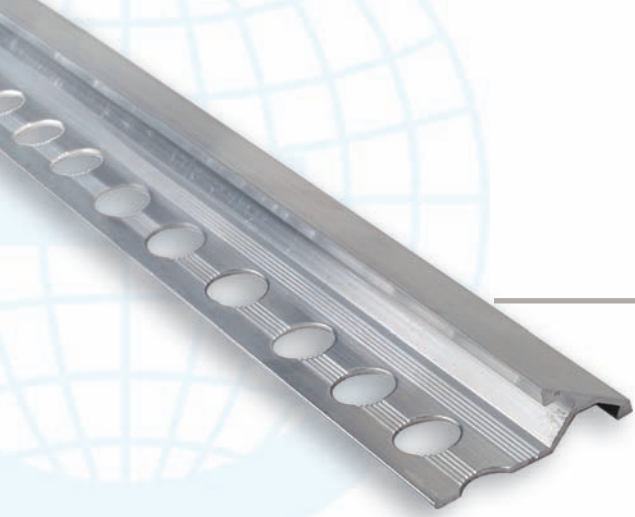

ES EUROTRANSICIÓN-201A, perfil de aluminio diseñado para rematar la transición entre diferentes pavimento. Permite vencer desniveles producidos entre diferentes materiales, como por ejemplo los producidos en las reformas al colocar un nuevo pavimento sobre el original. Apropiado para todo tipo de material como moqueta, parquet, cerámica, vinilo..., así como para zonas de mucho tránsito por su resistencia.

EN EUROTRANSITION-201A, aluminium profile designed to finish off the transition between different floorings. It allows to bridge differences in height between several materials, such as in renovations when a new flooring is applied over an old one. Suitable for any kind of material, for example carpet, parquet, ceramic, vinyl, as well as for busy areas, because of their high resistance.

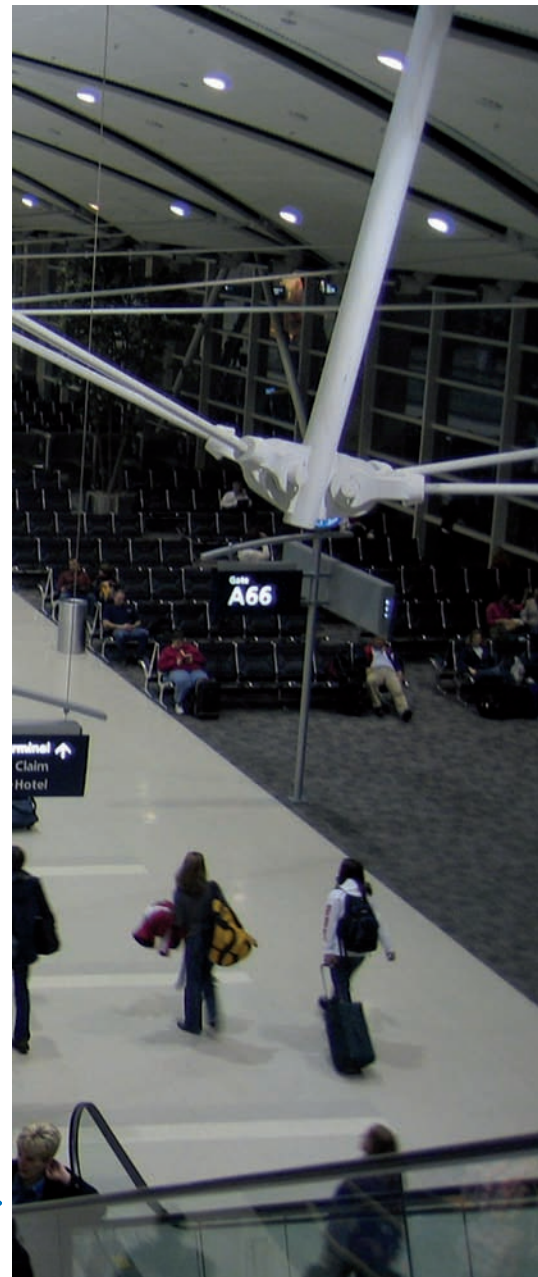

Longitud 2,50 m. Embalaje: 10 u/caja.
Lenght: 8,2 ft. Packing: 10 u/box.

Precio/Price: € /perfil

Referencia Reference	Colores Colours	h: 10 mm 3/8"		h: 12,5 mm 1/2"	
		a: 15 mm 9/16"		a: 23 mm 7/8"	
201A-PM	Plata mate		12,01		15,13
201A-OM	Oro mate		14,22		20,18

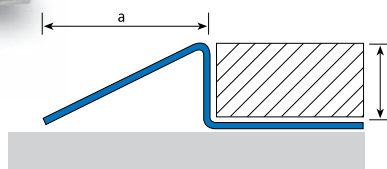
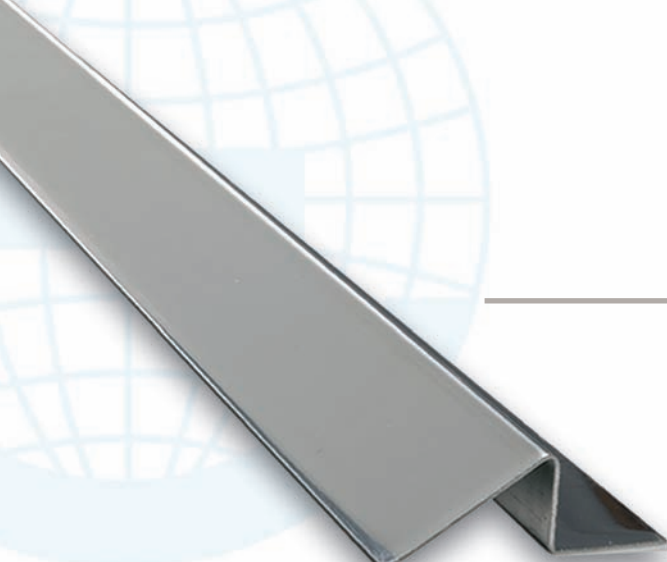

ES EUROTRANSICIÓN-201S, perfil de acero inoxidable diseñado para rematar la transición entre diferentes pavimento. Permite vencer desniveles producidos entre diferentes materiales, como por ejemplo en las reformas al colocar un nuevo pavimento sobre el original. Apropiado para todo tipo de material como moqueta, parquet, cerámica, vinilo..., así como para zonas de mucho tránsito por su resistencia.

EN EUROTRANSITION-201S, stainless steel profile designed to finish off the transition between different floorings. It allows to bridge differences in height between several materials, such as in renovations when a new flooring is applied over an old one. Suitable for any kind of material, for example carpet, parquet, ceramic, vinyl, as well as for busy areas, because of their high resistance.

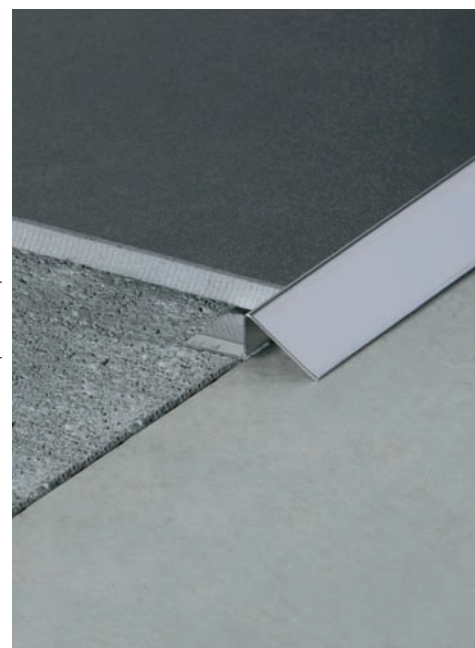

Longitud 2,50 m. Embalaje: 20 u/caja.

Lenght: 8,2 ft. Packing: 20 u/box.

Precio/Price: € /perfil

Referencia Reference	Colores Colours	h: 10 mm 3/8" a: 20 mm 3/4"	h: 12 mm 1/2" a: 22 mm 7/8"
201S-IB	Inox brillo	21,37	23,11
201S-IC	Inox cepillado	21,37	23,11

Con film protector / Whit protective tape. / AISI-304

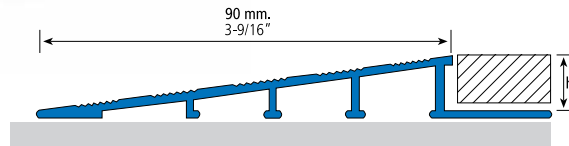
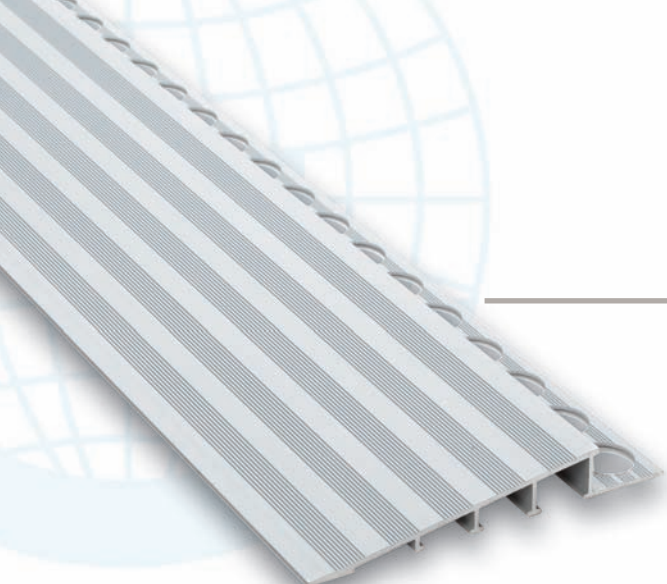

ES EUROTRANSICIÓN-240A, perfil de aluminio diseñado para rematar la transición entre diferentes pavimentos con desniveles. Debido a su amplia superficie de transición, 90 mm, puede ser usada en entradas a parkings, grandes almacenes o superficies para facilitar el tránsito rodado entre diferentes ambientes.

EN EUROTRANSITION-240A. This aluminium profile was designed to overcome the transition between floors with different heights. Thanks to its large transition surface of 90 mm, it can be used in car park entrances, department stores or surfaces in order to make wheeled traffic between different areas easier.



Longitud 2,50 m. Embalaje: 10 u/caja.
Lenght: 8,2 ft. Packing: 10 u/box.

Precio/Price: € /perfil

Referencia Reference	Colores Colours	h: 12,5 mm 1/2" a: 90 mm 3-9/16"
240A-PM	Plata mate	52,27

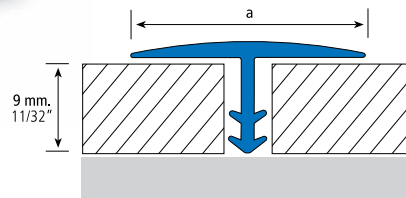
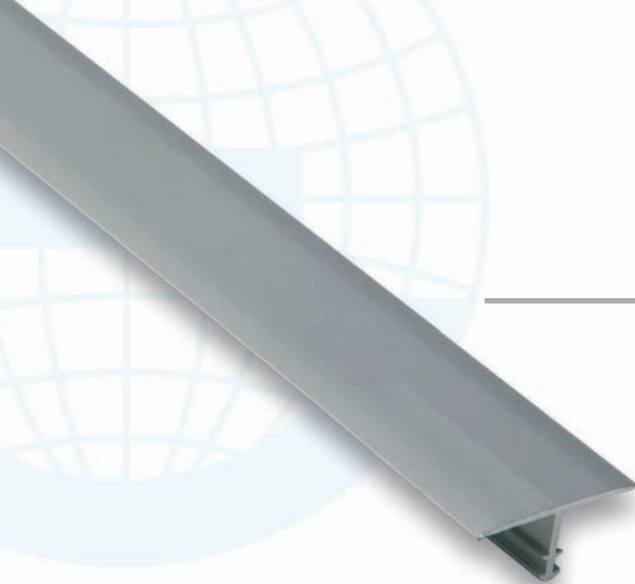

Transiciones
Transitions



ES EUROTRANSICIÓN-232A, perfil de aluminio en forma de T para transiciones entre pavimentos al mismo nivel o con desniveles mínimos. Se coloca entre ambos pavimentos con silicona que actúa como junta de dilatación, pues absorbe los movimientos de los mismos, y proporciona protección a los cantos del pavimento, cerámica o parquet, que de otra manera quedarían desprotegidos completamente.

EN EUROTRANSITION-232A, T-shaped aluminium profile for transitions between floorings on the same level or at minimal differences. Placing it between those floorings using silicone, it acts as a joint, while absorbing the movements and protecting the edges of floorings, regardless of whether they are made of ceramics or parquet, which otherwise would be left without any protection.

Longitud 2,50 m. Embalaje: 10 u/caja.

Length: 8,2 ft. Packing: 10 u/box.

Precio/Price: € /perfil

Referencia Reference	Colores Colours	a: 22 mm 7/8"
232A-PM	Plata mate	7,78
232A-OM	Oro mate	9,07

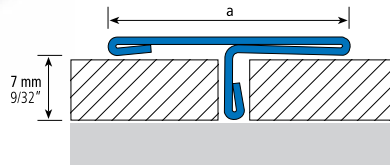

ES EUROTRANSICIÓN-232S, perfil de acero inoxidable en forma de T para transiciones entre pavimentos al mismo nivel o con desniveles mínimos. Se coloca entre ambos pavimentos con silicona que actúa como junta de dilatación, pues absorbe los movimientos de los mismos, y proporciona protección a los cantos del pavimento, cerámica o parquet, que de otra manera quedarían desprotegidos completamente.

EN EUROTRANSITION-232S, T-shaped stainless steel profile for transitions between floorings on the same level or at minimal differences. Placing it between those floorings using silicone, it acts as a joint, while absorbing the movements and protecting the edges of floorings, regardless of whether they are made of ceramics or parquet, which otherwise would be left without any protection.

Longitud 2,50 m. Embalaje: 20 u/caja.
Length: 8,2 ft. Packing: 20 u/box.

Precio/Price: € /perfil

Referencia Reference	Colores Colours	a: 25 mm 1"
232S-IB	Inox brillo	22,99
232S-IC	Inox cepillado	22,99

Con film protector / With protective tape. / AISI-304

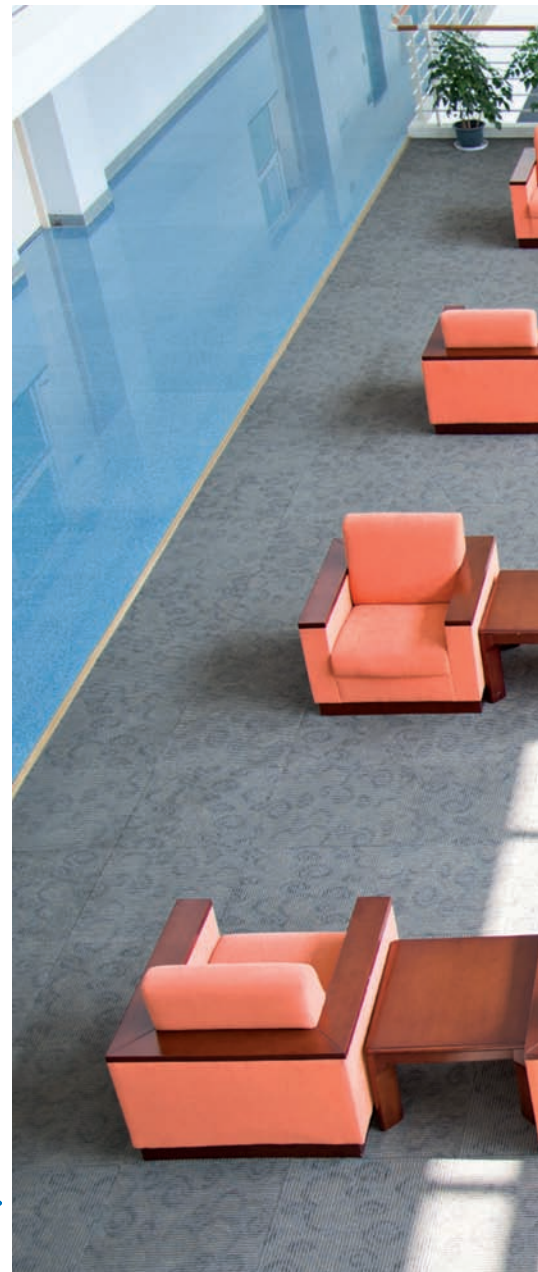
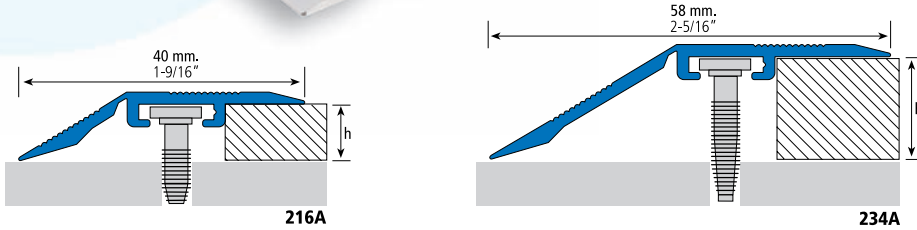

ES EUROTRANSICIÓN-216A y 234A, perfiles de aluminio para transiciones entre pavimentos, que permiten vencer desniveles desde 4 hasta 12 mm (216A) o desde 8 hasta 20 mm (234A), permitiendo la transición entre cualquier tipo de pavimento.

*Se suministra con tacos especiales que se insertan en la ranura interior del perfil, quedando totalmente ocultos.

EN EUROTRANSITION-216A and 234A, aluminium profiles for the transition between floorings that helps to bridge differences in height from 4 up to 12 mm (216A) or from 8 up to 20 mm (234A), between any kind of flooring.

*It is supplied with special plugs that are inserted in the inner slot of the profile and thus stay completely hidden.

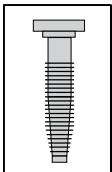

*Taco especial /Especial plug Medida/Size: 5 x 42 mm

h: 4-12 mm. Embalaje: 10 u/caja.

h: 5/32" - 1/2". Packing: 10 u/box.

Precio/Price: €

Referencia Reference	Colores Colours	L: 1 m 3,28 ft	L: 2 m 6,56 ft
216A-PM	Plata mate	8,39	16,79
216A-OM	Oro mate	10,17	20,34
216A-BRM	Bronce mate	10,17	20,34

h: 8-20 mm. Embalaje: 10 u/caja.

h: 5/16" - 3/4". Packing: 10 u/box.

Precio/Price: €

Referencia Reference	Colores Colours	L: 1 m 3,28 ft	L: 2 m 6,56 ft
234A-PM	Plata mate	11,76	23,53
234A-OM	Oro mate	14,52	29,04
234A-BRM	Bronce mate	14,52	29,04

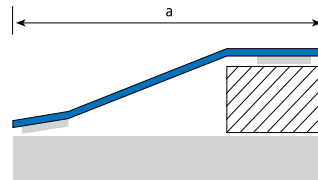
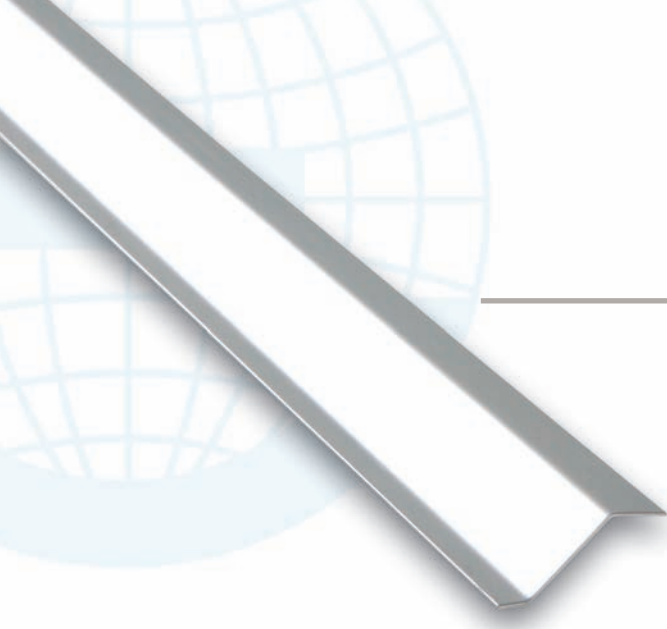

(AD) Autoadhesivo /self adhesive

ES EUROTRANSICIÓN-262S, perfil de acero inoxidable autoadhesivo para transiciones entre pavimentos que permite vencer desniveles entre 8 hasta 12 mm, facilitando la transición entre cualquier tipo de pavimento. La Eurotransición-262S se suministra con tiras adhesivas para su colocación inmediata.

EN EUROTRANSITION-262S, In order to overcome an unevenness of 8 to 12mm, these self-adhesive profiles made of stainless steel can be used to make the transition between any kind of flooring. This product is supplied with adhesive strips which enable an immediate attachment on all types of floorings.

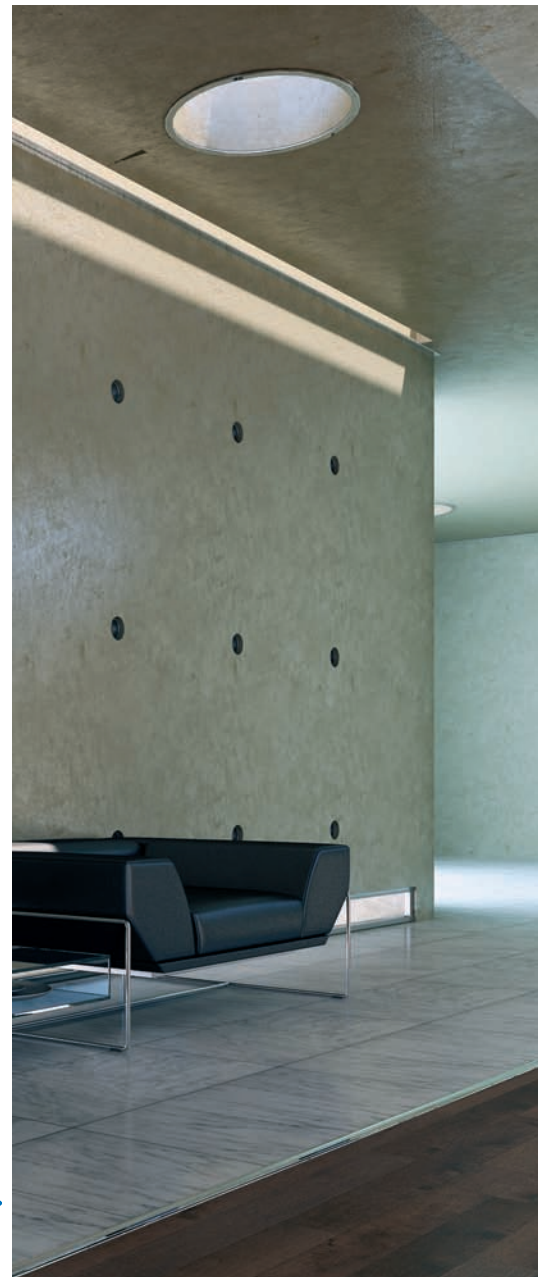
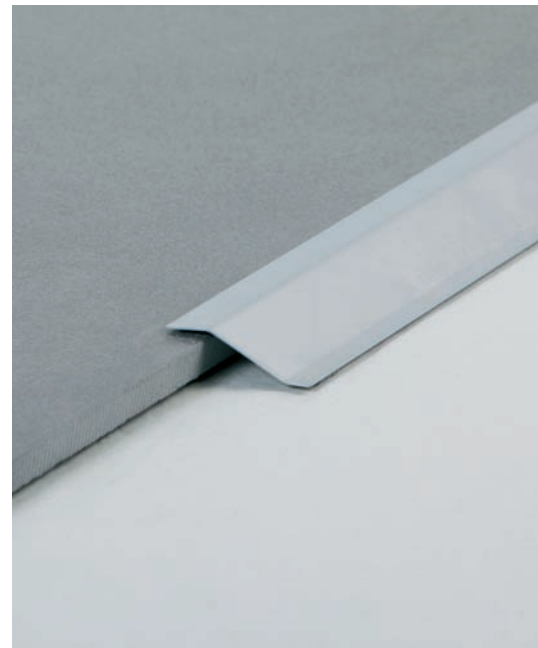

h: 8-12 mm. a: 40 mm. Embalaje: 20 u/caja.
h: 5/16" - 1/2". a: 1-9/16". Packing: 20 u/box.

Precio/Price: €

Referencia Reference	Colores Colours	L: 1 m 3,28 ft	L: 2,5 m 8,20 ft
262S-IB/AD	Inox brillo	13,67	26,71

Con film protector / Whit protective tape. / AISI-304 (AD) Autoadhesivo / Self-adhesive

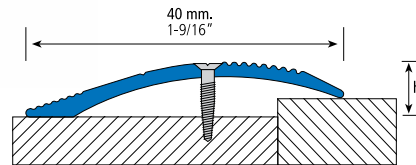

Transiciones
Transitions

ES EUROTRANSICIÓN-218A, perfil de aluminio para transiciones entre pavimentos, que permite vencer desniveles desde 0 hasta 15 mm, permitiendo la transición entre cualquier tipo de pavimento.
*El perfil se suministra perforado, con tornillos y tacos, retráctilado al completo

EN EUROTRANSITION-218A, aluminium profile for transitions between floorings that helps to bridge differences in height from 0 up to 15 mm, between any kind of flooring.
*It is supplied with drillings, screws and plugs, and completely shrink-wrapped in a full package.

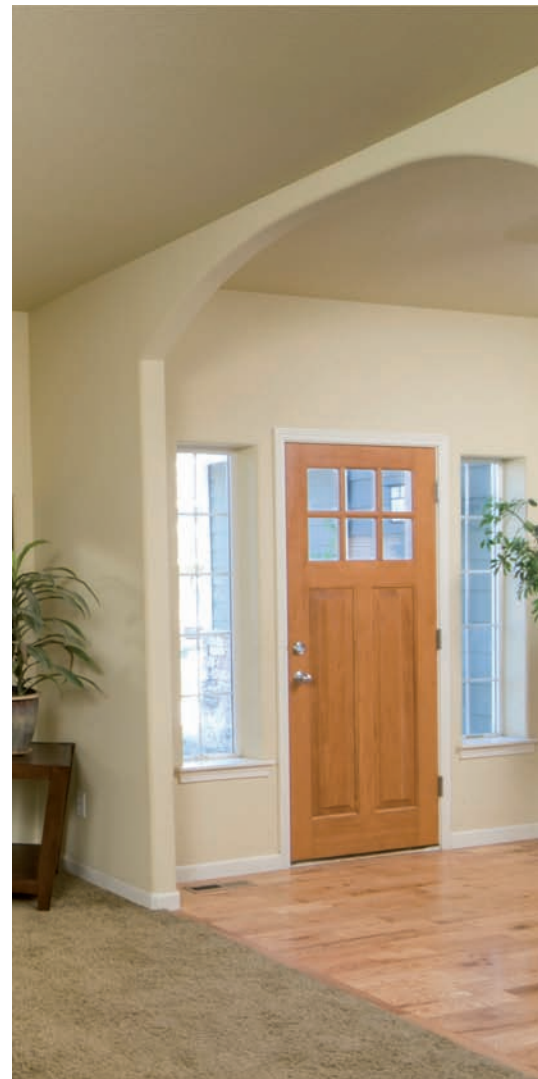

h: 0-15 mm. Embalaje: 10 u/caja.
h: 0" - 9/16". Packing: 10 u/box.

Precio/Price: €

Referencia Reference	Colores Colours	L: 1 m 3,28 ft	L: 2 m 6,56 ft
218A-PM	Plata mate	8,52	17,03
218A-OM	Oro mate	9,99	19,97

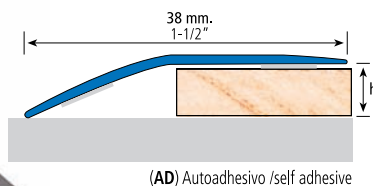

ES EUROTRANSICION-292A, Perfil autoadhesivo de aluminio para transiciones entre parquets o diferentes tipos de pavimento, que permite vencer desniveles entre 10 y 15 mm. La Eurotransición se presenta en aluminio anodizado o en acabado decorativo de madera (lámina de PVC resistente a los productos habituales de limpieza no abrasivos)

EN EUROTRANSICION-292A, Self-adhesive aluminium profile for transitions between parquets or different types of flooring which allows unevenness of between 10 and 15 mm to be overcome. The Eurotransición is made of anodised aluminium or a decorative wooden finish (PVC sheet resistant to the usual non-abrasive cleaning products).

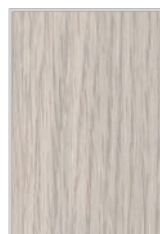

Roble Claro (RC)



Roble Natural (RN)



Haya (HA)

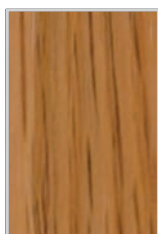

Roble (RO)



Cerezo (CE)

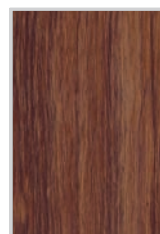

Sapelly (SA)



Nogal Satinado (NS)

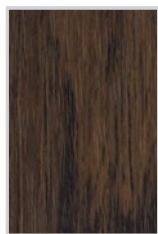

Nogal (NO)



Madera Gris Claro (MGC)



Madera Gris (MG)

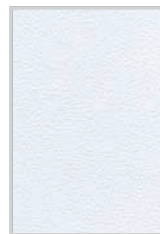

Blanco 2 (BL2)



Plata Mate (PM)



Oro Mate (OM)

Precio/Price: €

Referencia Referencia	Colores Colours	Altura (h) Height (h)	Longitud Lenght	€/ m.	Unidades / Caja Units / Box
292A/AD Aluminio 292A/AD Aluminium	Blanco 2	White 2	1 m. 3,28 ft.	10,72	10
	Plata mate	Matt silver			
	Oro mate	Matt gold			
	Roble Claro	Light Oak			
	Roble Natural	Natural Oak			
	Haya	Beech			
	Roble	Oak			
	Cerezo	Cherry			
	Sapelly	Sapelly			
	Nogal Satinado	Satin Walnut			
	Nogal	Walnut			
	Madera G. Claro	Light Grey Wood			
	Madera Gris	Grey Wood			

(AD) Autoadhesivo / Self-adhesive

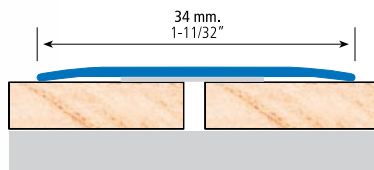
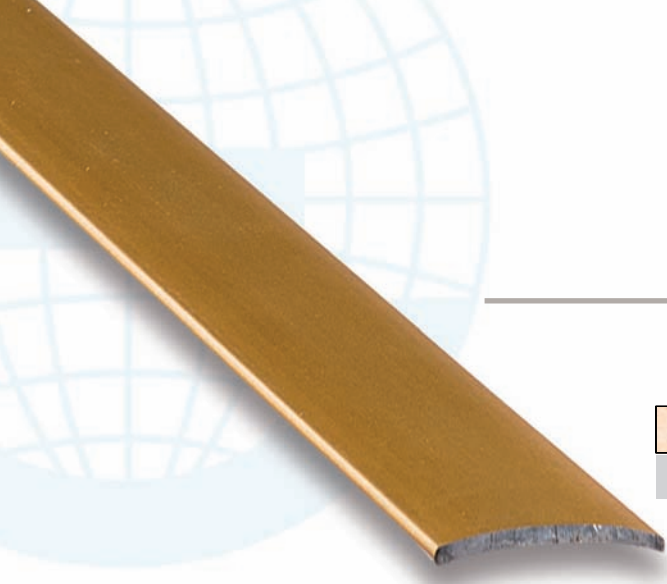

(AD) Autoadhesivo /self adhesive

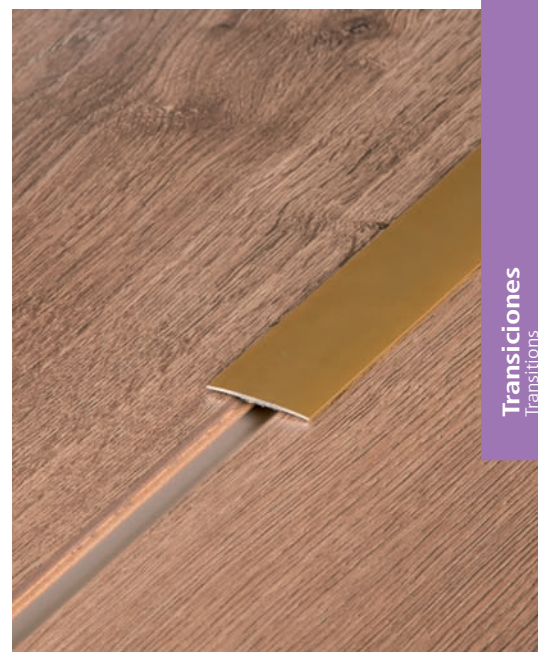

Transiciones
Transitions

ES EUROTRANSICION-290A, Perfil autoadhesivo de aluminio para su uso como junta de dilatación o transiciones al mismo nivel entre parquets o diferentes tipos de pavimento. La Eurotransición se presenta en aluminio anodizado o en acabado decorativo de madera (lámina de PVC resistente a los productos habituales de limpieza no abrasivos) Se suministra con tiras adhesivas para su colocación inmediata.

EN EUROTRANSITION-290A, Self-adhesive aluminium profile for use as an expansion joint or for transitions at the same level between parquets or different types of flooring. The Eurotransition is made of anodised aluminium or a decorative wooden finish (PVC sheet resistant to the usual non-abrasive cleaning products) It is supplied with adhesive strips for immediate laying



Precio/Price: €

Referencia Referencia	Colores Colours	Altura (h) Height (h)	Longitud Lenght	€/ m.	Unidades / Caja Units / Box
290A/AD Aluminio 290A/AD Aluminium	Blanco 2 White 2 Plata mate Matt silver Oro mate Matt gold Roble Claro Light Oak Roble Natural Natural Oak Haya Beech Roble Oak Cerezo Cherry Sapelly Sapelly Nogal Satinado Satin Walnut Nogal Walnut Madera G. Claro Light Grey Wood Madera Gris Grey Wood	0 mm 0"	1 m. 3,28 ft.	10,36	10

(AD) Autoadhesivo / Self-adhesive



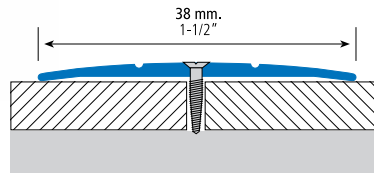

ES EUROTRANSICIÓN-217A, perfil de aluminio para transiciones entre pavimentos, que permite vencer desniveles desde 0 hasta 5 mm, permitiendo la transición entre cualquier tipo de pavimento.
*El perfil se suministra perforado, con tornillos y tacos, retractilado al completo.

EN EUROTRANSITION-217A, aluminium profile for transitions between floorings that helps to bridge differences in height from 0 up to 5 mm, between any kind of flooring.
*It is supplied with drillings, screws and plugs, and completely shrink-wrapped in a full package.

h: 0-5 mm. Embalaje: 10 u/caja.
h: 0" - 3/16". Packing: 10 u/box.

Precio/Price: €

Referencia Reference	Colores Colours	L: 1 m 3,28 ft	L: 2 m 6,56 ft
217A-PM	Plata mate	6,56	13,11
217A-OM	Oro mate	7,60	15,20
217A-BRM	Bronce mate	7,60	15,20

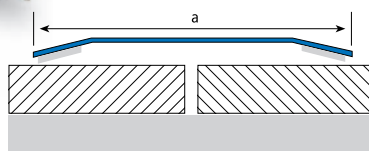

(AD) Autoadhesivo /self adhesive

ES EUROTRANSICIÓN-261S, perfil de acero inoxidable autoadhesivo para transiciones entre pavimentos, que permite vencer desniveles desde 0 hasta 5 mm, permitiendo la transición entre cualquier tipo de pavimento. La Eurotransición-261S se suministra con tiras adhesivas para su colocación inmediata.

EN EUROTRANSITION-261S. In order to overcome an unevenness of 0 to 5mm, these self-adhesive profiles made of stainless steel can be used to make the transition between any kind of flooring. This product is supplied with adhesive strips which enable an immediate attachment on all types of floorings.



h: 0-5 mm, a: 40 mm. Embalaje: 20 u/caja.
h: 0" - 3/16" . a: 1-9/16" . Packing: 20 u/box.

Precio/Price: €

Referencia Reference	Colores Colours	L: 1 m 3,28 ft	L: 2,5 m 8,20 ft
261S-IB/AD	Inox brillo	13,67	26,71

(AD) Autoadhesivo / Self adhesive

Con film protector / Whit protective tape. / AISI-304

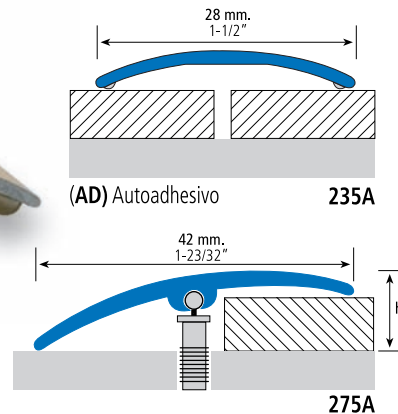

ES EUROTRANSICIÓN, perfil de Aluminio para transiciones entre pavimentos: parquet-moqueta, parquet-gres, moqueta-gres, ...

235A, Se suministra con tiras autoadhesivas que facilitan su colocación sin necesidad de perforar el suelo.

275A, Se suministra con tacos especiales que se insertan en la ranura interior del perfil, quedando totalmente ocultos.

EN EUROTRANSITION, aluminium profile for the transition between floorings, such as parquet and fitted carpets, parquet and stoneware, fitted carpets and stoneware, etc.

235A, It is supplied with self-adhesive strips which help its placement and makes drilling holes the floor unnecessary.

275A, It is supplied with special plugs that are inserted in the inner slot of the profile and thus stay completely hidden.

h: 0-10 mm. Embalaje: 10 u/caja.

h: 0" - 3/8". Packing: 10 u/box.

Precio/Price: €

Referencia Reference	Colores Colours	L: 1 m 3,28 ft	L: 2 m 6,56 ft
235A-PM	Plata mate	8,27	16,54
235A-OM	Oro mate	9,13	18,26
235A-BRM	Bronce mate	9,13	18,26
235A-HA	Haya	10,17	20,34
235A-RO	Roble	10,17	20,34
235A-CE	Cerezo	10,17	20,34
235A-NO	Nogal	10,17	20,34
235A-WE	Wenge	10,17	20,34

(AD) Autoadhesivo / Self adhesive

h: 0-16 mm. Embalaje: 10 u/caja.

h: 0" - 5/8". Packing: 10 u/box.

Taco especial: 5 x 48 mm
Especial plug : 3/16" x 1-7/8"



275A-PM	Plata mate	9,84	19,69
275A-HA	Haya	12,87	25,74
275A-RO	Roble	12,87	25,74
275A-CE	Cerezo	12,87	25,74
275A-NO	Nogal	12,87	25,74
275A-WE	Wenge	12,87	25,74
275A-RN	Roble Natural		25,74
275A-RC	Roble Claro		25,74
275A-MGC	Mad. Gris claro		25,74
275A-BL2	Blanco 2		25,74

Gama de color / Colour range. Pag.168



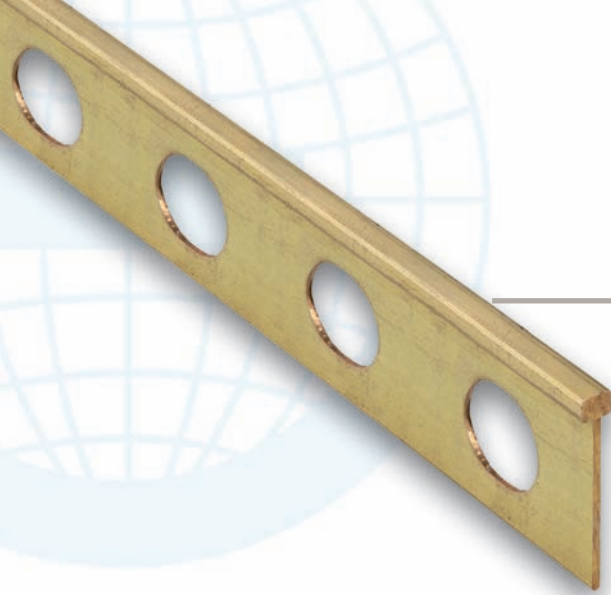

274A



(A) Aluminio/Aluminium (L) Laton/Brass

274L

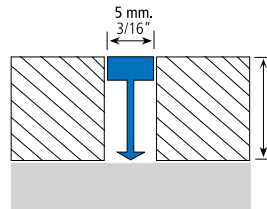
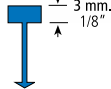

ES EUROTRANSICIÓN, Perfil para separar o decorar superficies de terrazo, cerámica, ...
Disponible en aluminio o latón natural, para poder ser pulidos a la vez que el pavimento.

EN EUROTRANSITION, Profile to separate or decorate terrace surfaces, ceramics, ...
Available in aluminium or natural brass so they can be polished at the same time as the flooring.



Transiciones
Transitions

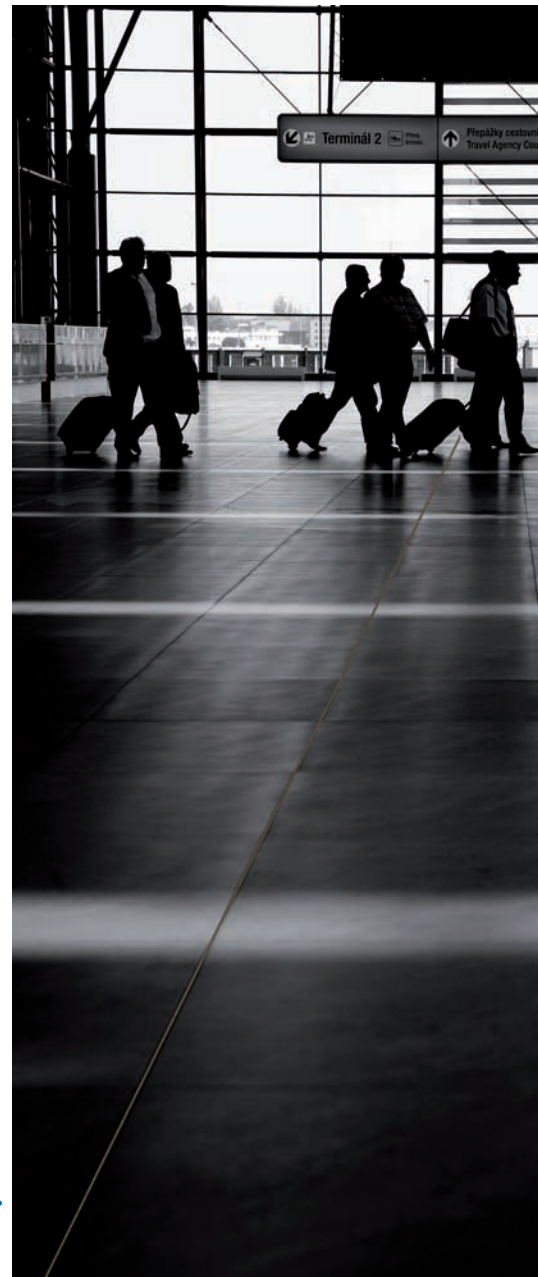

Aluminio - Longitud 2,50 m. Embalaje: 30 u/caja.

Aluminium - Length: 8,2 ft. Packing: 30 u/box.

Precio/Price: € /perfil

Referencia Reference	Colores Colours	h: 20 mm 3/4"
274A-NAT	Aluminio natural	19,42

Latón - Longitud 2,50 m. Embalaje: 20 u/caja.

Brass - Length: 8,2 ft. Packing: 20 u/box.

Referencia Reference	Colores Colours	h: 10 mm 3/8"	h: 25 mm 1"
		274L-NAT	Latón natural
274L-NAT	Latón natural		51,61

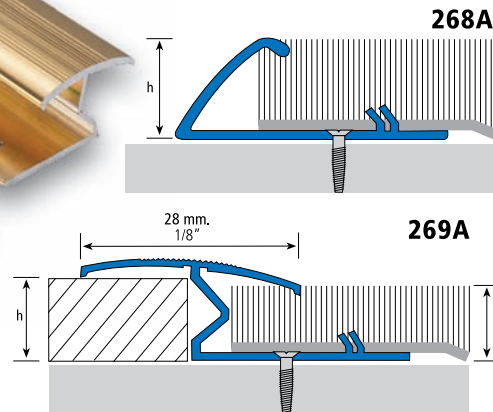
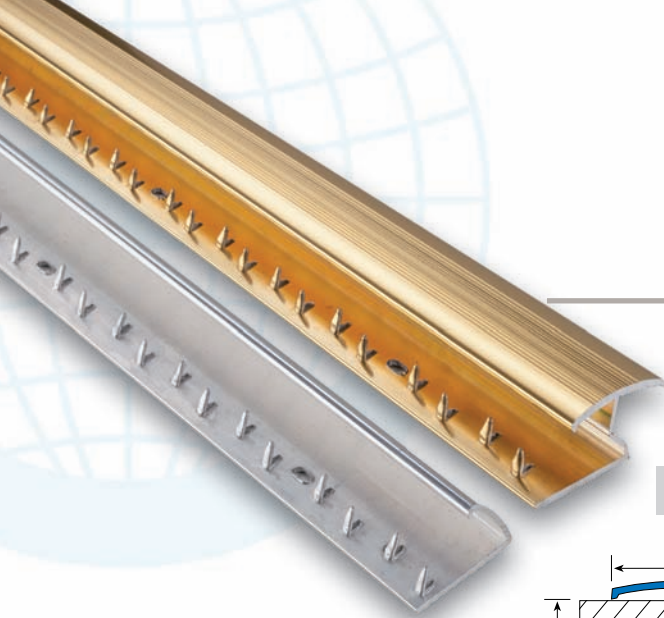

ES EUROTRANSICIÓN, Perfiles de aluminio destinados al remate final de moqueta, proporcionando un acabado perfecto y elegante. La sujeción de la moqueta se realiza mediante la fijación a los ganchos existentes en la base del perfil, y posterior tensión de la moqueta.
*El perfil se suministra perforado, con tornillos y tacos, retractilado al completo.

EN EUROTRANSITION, Aluminium profiles intended for the final finish on fitted carpet, affording a perfect, elegant finish. The fitted carpet is secured by affixation to the hooks to be found at the profile base and the subsequent tension of the fitted carpet.
*It is supplied with drillings, screws and plugs, and completely shrink-wrapped in a full package.

Longitud: 2,50 m. Embalaje: 10 u/caja.
Lenght: 8,2 ft. Packing: 10 u/box.

Precio/Price: €

Referencia Reference	Colores Colours	h: 8-12 mm h: 5/16" - 1/2"	h: 8-10 mm h: 5/16" - 3/8"
268A-PM	Plata mate	15,75	
268A-OM	Oro mate	18,20	
268A-BRM	Bronce mate	18,20	
269A-PM	Plata mate		22,85
269A-OM	Oro mate		27,27
269A-BRM	Bronce mate		27,27



La instalación de juntas de dilatación es necesaria en el momento de la colocación de cualquier pavimento. La junta absorbe los esfuerzos de presión y tracción, así como la dilatación del pavimento en general, evitando los desperfectos o roturas del mismo debido a cambios de temperatura, deformación por compresión y agresiones climáticas

The use of expansion joints is necessary when installing any kind of flooring or covering. The joint absorbs pressure or tension stress, as well as the habitual flooring expansion. This way you can avoid damage or breakage because of temperature changes, distortion through compression and aggressive climate changes.

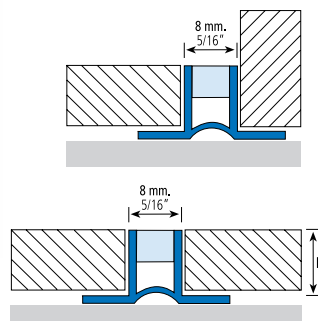
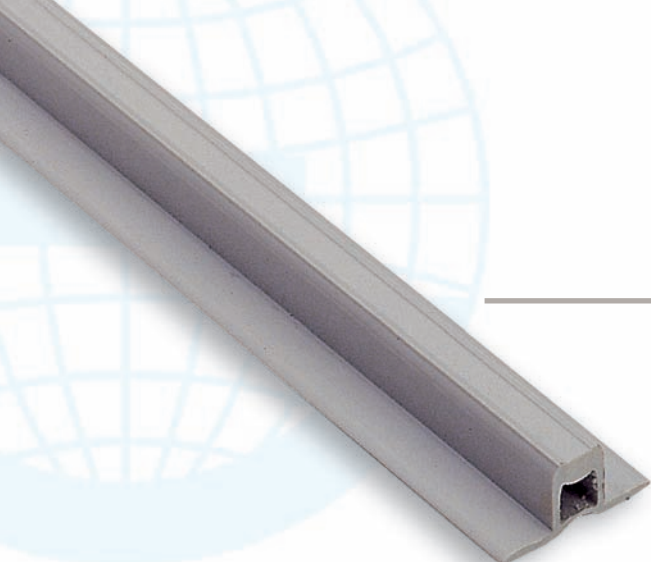

ES EUROJUNTA-185, perfil fabricado en coextrusión combinando PVC rígido y flexible para juntas móviles y destinado a pavimentos cerámicos. La parte superior formada por la unión del material rígido y flexible tiene una anchura de 10 mm., de esta manera absorbe esfuerzos de presión y tracción, así como los producidos por movimientos de desnivel. Siendo adecuada para revestimientos y pavimentos, de interior o exterior, en zonas que sufren esfuerzos mecánicos como locales comerciales, en los cuales hay movimientos de carros de compra o esfuerzos similares.

EN EUROJOINT-185, profile made in co-extrusion combining rigid and flexible PVC, for moving joints and set it aside for ceramic flooring. The upper part formed by the joining of the rigid and flexible material has a width of 10 mm, thus absorbing pressure and traction stress, as well as stress caused by levelling movements. It is well-suited to coatings and floorings, indoor or outdoor, with areas subject to mechanical stress, like commercial areas with trolley or similar uses.



Longitud 2,5 m. Embalaje: 100 u/caja.

Lenght: 8,2 ft. Packing: 100 u/box.

Precio/Price: € /perfil

Referencia Reference	Colores Colours	h: 8 mm 5/16"	h: 10 mm 3/8"	h: 12 mm 1/2"	h: 15 mm 9/16"	h: 20 mm 3/4"
185-BL	Blanco		4,04	6,42		
185-CH	Champagne		4,04	6,42		
185-BE	Beige		4,04	6,42		
185-BG	Beige-G		4,04	6,42		
185-GR	Gris	3,98	4,04	6,42	6,80	7,19
185-MA	Marron		4,04	6,42	6,80	
185-NE	Negro	3,98	4,04	6,42		7,19

*Posibilidad de combinar la parte flexible en transparente.
*It could be possible to combine the flexible / PVC in transparent.

Gama de color / Colour range. Pag.166



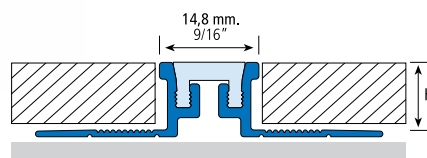
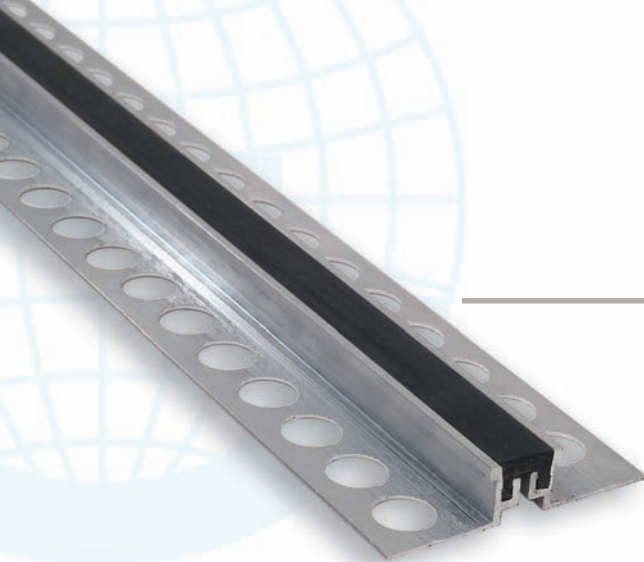

ES EUROJUNTA-214A, junta de dilatación compuesta por dos partes exteriores de aluminio unidas mediante un perfil de caucho sintético flexible, que es altamente resistente a las agresiones externas (cambios de temperatura, deformación por compresión y agresiones climáticas). La junta absorbe los esfuerzos de presión y tracción, así como la dilatación del pavimento en general, evitando los desperfectos o roturas del mismo debido a la forma protectora de los cantos de aluminio de los perfiles exteriores. Destinado a juntas entre pavimentos cerámicos, de interior o exterior, tanto domésticos como en zonas industriales, almacenes, hospitales, centros comerciales. En caso de desgaste la parte de caucho puede sustituirse fácilmente. Es aconsejable en su colocación dejar el perfil 1mm por debajo del nivel del pavimento.

EN EUROJOINT-214A, expansion joint made of two exterior aluminium parts linked by a synthetic and flexible rubber profile, which is highly resistant to external influences (such as temperature changes, deformation due to compression and influences of the weather). The joint absorbs the pressure and traction stress, as well as the flooring expansion in general, avoiding flaws or breakage thanks to the protective shape of the aluminium edges. It is used for joints between indoor or outdoor ceramic floorings, both for domestic use and industrial areas, stores, hospitals, and shopping centres. If the rubber part should wear out, it can be easily replaced. It is advisable to place the stripping 1 mm under the flooring level.



Juntas de dilatación
Expansion Joint

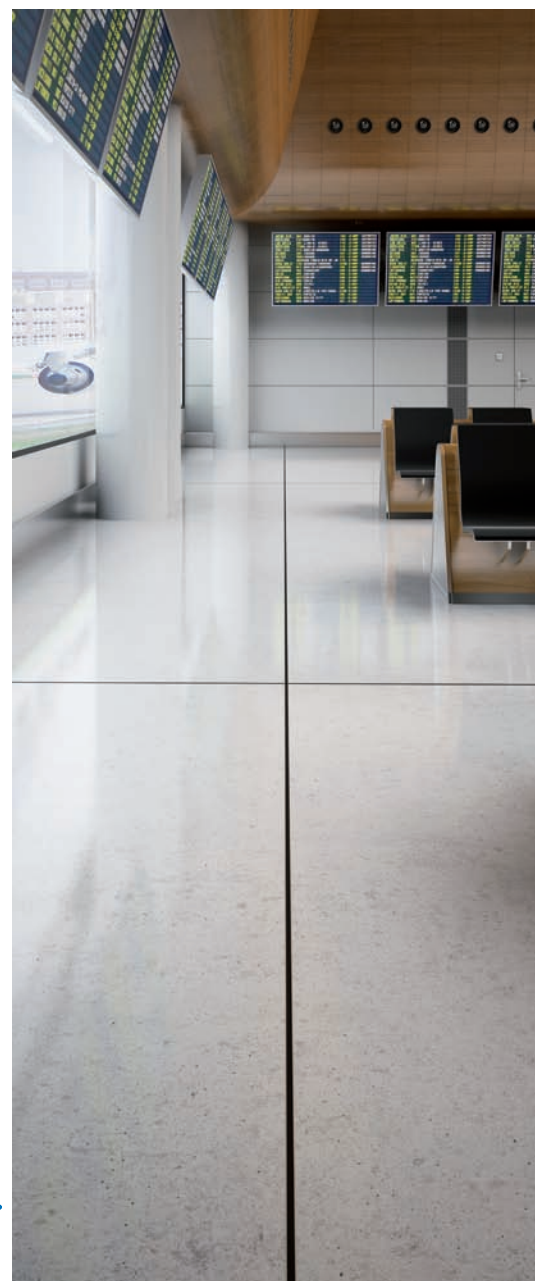

Longitud 2,50 m. Embalaje: 10 u/caja.

Lenght: 8,2 ft. Packing: 10 u/box.

Precio/Price: € /perfil

Referencia Reference	Colores Colours	h: 10 mm 3/8"	h: 12,5 mm 1/2"
214A-GR	Gris	29,50	32,50
214A-BE	Beige	32,25	34,70
214A-NE	Negro	29,50	32,50

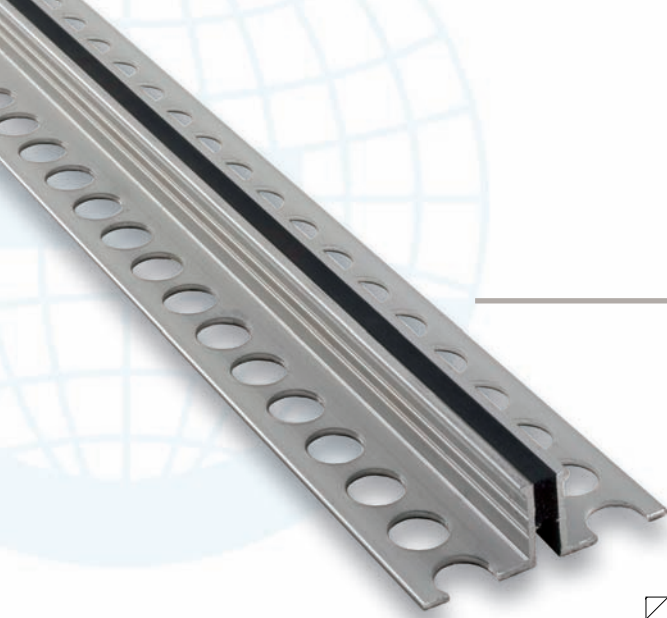

Soluciones para
Juntas de Dilatación
Expansion Joint Solutions

ALUMINIO / ALUMINIUM
INOXIDABLE / STAINLESS STEEL

223A/223S

223A

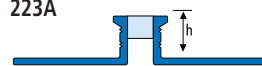

(A) Aluminio/Aluminium

223S



(S) Acero Inoxidable/Stainless Steel

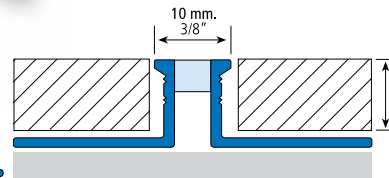

ES EUROJUNTA-223A, junta de dilatación con una parte visible de 10 mm., compuesta por dos perfiles exteriores de aluminio unidos mediante un perfil de caucho sintético flexible mejorado, que proporciona una excelente resistencia a la tensión, a la abrasión y a la fatiga por flexión. Se ha utilizado este nuevo material porque se adhiere perfectamente a las dos partes del aluminio y es altamente resistente a las agresiones externas (temperatura, clima, productos de limpieza habituales, ...). La EUROJUNTA-223A absorbe los esfuerzos de presión y tracción, así como la dilatación del pavimento en general, evitando los desperfectos o roturas del mismo debido a la forma protectora de los cantos de aluminio externos. Destinado a juntas entre pavimentos cerámicos, de interior o exterior, tanto domésticos como en zonas industriales, almacenes, hospitales, centros comerciales, etc. Es aconsejable en su colocación dejar el perfil 1 mm. por debajo del nivel del pavimento.

EN EUROJOINT-223A, expansion joint with a visible part of 10 mm, made of two external aluminium profiles that are linked by an enhanced synthetic and flexible rubber profile. It provides an excellent resistance to tension, abrasion and fatigue due to flexion. This new material has been employed, because it sticks perfectly to the two aluminium parts and is highly resistant to external influences (different temperatures, weather, common cleaning products, ...). EUROJOINT-223A absorbs the pressure and traction stress, and also the flooring expansion in general, avoiding flaws or breakage due to the protective shape of the external aluminium edges. It is used for joints between indoor or outdoor ceramic floorings, both for domestic use and industrial areas, stores, hospitals, shopping centres, etc. It is advisable to place the stripping 1 mm under the flooring level.



Aluminio - Longitud 2,50 m. Embalaje: 10 u/caja.

Aluminium - Length: 8,2 ft. Packing: 10 u/box.

Precio/Price: € /perfil

Referencia Reference	Colores Colours	h: 4,5 mm 3/16"	h: 10 mm 3/8"	h: 12 mm 1/2"	h: 15 mm 9/16"	h: 22,5 mm 7/8"
SLIM 223A-GR	Gris	43,33				
223A-GR	Gris		45,40	47,36	55,70	70,71
223A-NE	Negro		45,40	47,36		

Acero inoxidable - Longitud 2,50 m. Embalaje: 20 u/caja.

Stainless steel - Length: 8,2 ft. Packing: 20 u/box.

223S-GR	Gris		63,99	67,09		
---------	------	--	-------	-------	--	--

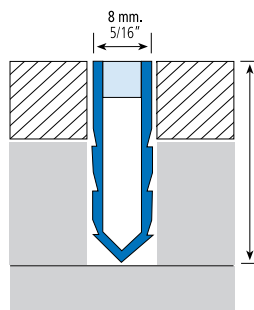

ES EUROJUNTA-186, junta de dilatación compuesta por dos partes: una rígida y otra flexible. Utilizada en el montaje con pavimentos, baldosas, piedra natural, etc. La función de este producto es compensar los esfuerzos de presión impidiendo la rotura del pavimento, gracias a su parte central flexible.

EN EUROJOINT-186, expansion joint made up of two sections - one rigid and another flexible. Used during installation of flooring, tiles, natural stone, etc. Thanks to its flexible central section, this product makes up for pressure stress.



Juntas de dilatación
Expansion Joint



Longitud 2,5 m. Embalaje: 50 u/caja.

Length: 8,2 ft. Packing: 50 u/box.

Precio/Price: € /perfil

Referencia Reference	Colores Colours	h: 30 mm 1-3/16"
186-BL	*Blanco	7,10
186-CH	*Champagne	7,10
186-BE	Beige	7,10
186-BG	*Beige-G	7,10
186-GR	Gris	7,10
186-MA	*Marron	7,10
186-NE	*Negro	7,10

*Descatalogado, disponible hasta fin de stock / Out of production, available till end of stock.





Las Euroescocias están desarrolladas para su uso en esquinas interiores entre paredes alicatadas, entre paredes y baños así como entre pared-suelo. El perfil redondea la esquina facilitando la limpieza de la misma, por lo que su uso está recomendado en todo espacio público que requiera una limpieza e higiene minuciosa, como por ejemplo en la industria alimentaria, establecimientos sanitarios, instituciones educativas,... Por último queremos remarcar que las Euroescocias se complementan con piezas especiales de unión que proporcionan un acabado perfecto.

The purpose of these products is the use in inner corners between walls with tilings, between walls and bathrooms and in transitions between walls and the floor. The profiles round off the corners and thus make cleaning easier. For this reason, they are recommended for all kinds of public spaces with strict cleaning and hygiene regulations, e.g. in the food industry, in sanitary facilities, educational institutions, and others. We would like to point out that this product can be combined with special joint pieces, which create the perfect finishing.

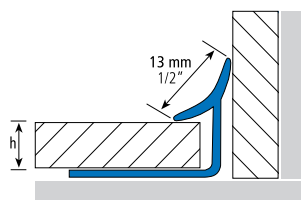
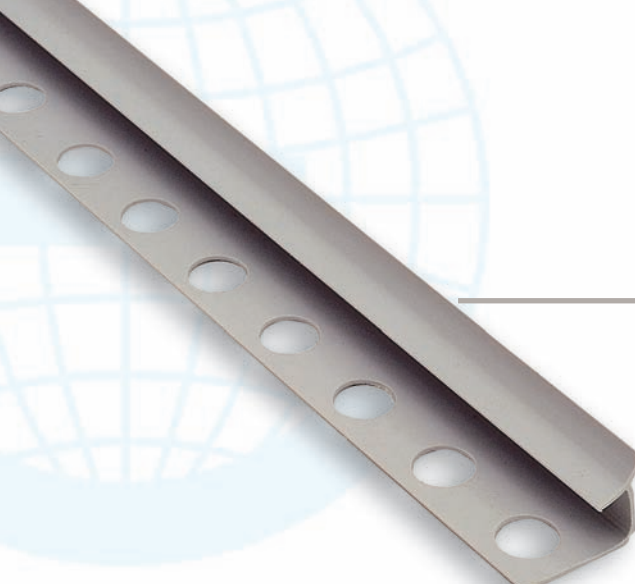

ES EUROESCOCIA-191, perfil de PVC utilizado principalmente para los ángulos interiores de paredes. No obstante también puede utilizarse para el ensamblaje del encuentro pared-suelo, en el cual se aconseja sólo la utilización de la gama de colores.

Compensa los movimientos horizontales y verticales existentes entre la pared y el suelo.

Este perfil cumple con las normativas de higiene y limpieza requeridas para la industria alimentaria, hospitales, cocinas industriales o lugares similares.

EN EUROCOVER-191, PVC profile used mainly for internal corners. However, it can also be used to assemble the wall-floor joint, where only the use of the range of colours is advised. Compensates the horizontal and vertical movement existing between the wall and floor.

This profile meets special sanitising and cleaning standards required by the food industry, industrial kitchens, hospitals or similar sites.



Longitud 2,55 m. Embalaje: 150 u/caja.

Lenght: 8,36 ft. Packing: 150 u/box.

Precio/Price: € /perfil

Referencia Reference	Colores Colours	h: 6 mm 1/4"	h: 8 mm 5/16"	h: 10 mm 3/8"	h: 12 mm 1/2"
191-BL	Blanco	2,23	2,26	2,26	2,40
191-CR	Crema			2,26	2,40

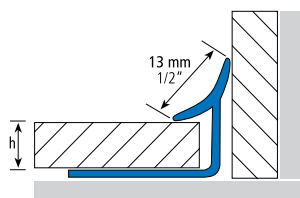
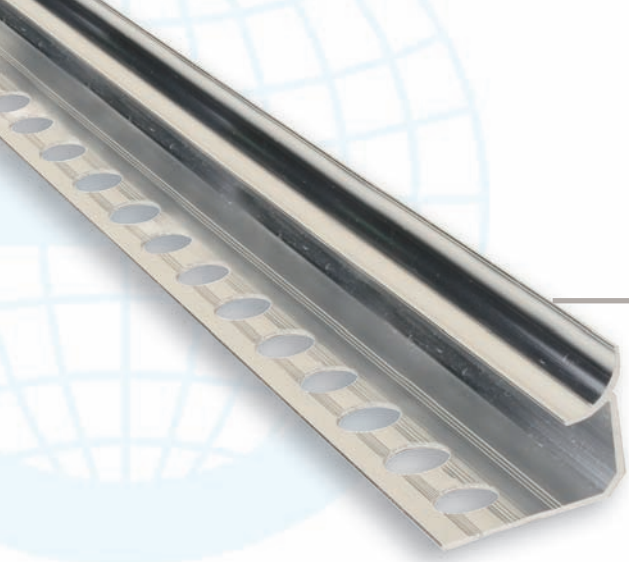

ES EUROESCOCIA-191A, perfil de aluminio para el acabado de las esquinas interiores de paredes, así como para el remate de pared con suelo. Ideado para la compensación de los movimientos horizontales y verticales existentes, tanto entre paredes como en el encuentro de pared y suelo. La EUROESCOCIA-191A cumple con las condiciones especiales de higiene y limpieza requeridas para la industria alimentaria, cocinas industriales, hospitales, etc., pudiendo aplicarse también para uso doméstico y conseguir un mejor acabado, más limpio y decorativo.

El perfil ha sido producido en aluminio para darle una mayor dureza y durabilidad, así como para adaptarse a las nuevas tendencias estéticas del momento, en las que se destacan materiales más nobles, para conseguir acabados con una mayor vistosidad. Este perfil dispone de piezas especiales para ensamblar las esquinas entre dos o tres perfiles:

• **I-191A:** Esquina interior • **E-191A:** Esquina exterior

EN EUROCOVE-191A, aluminium profile used for the finishing of internal wall corners, as well as to finish off the joint between the wall and the floor. It was conceived to make up for the existing horizontal and vertical movements, both between walls and the point where the wall joins the floor. EUROCOVE-191A complies with special hygienic and cleaning standards required by the food industry, industrial kitchens, hospitals, etc. It can also be used for domestic use in order to obtain a better, cleaner and more decorative finishing.

This profile was produced applying aluminium to enhance the hardness and durability, as well as to adapt it to the current aesthetic trends which primarily employ more noble materials to achieve more eye-catching finishings.

This profile has special connecting pieces for internal or external corners, these allow the connection between two or three profiles: • **I-191A:** Internal corner • **E-191A:** External corner

Longitud 2,50 m. Embalaje: 10 u/caja.

Lenght: 8,2 ft. Packing: 10 u/box.

Precio/Price: € /perfil

Referencia Reference	Colores Colours	h: 9 mm 11/32"	h: 12 mm 1/2"
191A-BL	Blanco	13,54	14,34
191A-PB	Plata brillo	16,48	17,46
191A-PM	Plata mate	12,99	13,66
191A-NM	Negro mate	16,93	17,70



E-191A (esquina exterior / external corner)

Blister: 1 u.

E-191A-BL	Blanco	18,38	18,38
E-191A-PB	Plata brillo	18,38	18,38
E-191A-PM	Plata mate	18,38	18,38
E-191A-NM	Negro mate	18,38	18,38

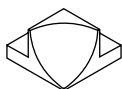

I-191A (esquina interior / internal corner)

Blister: 1 u.

I-191A-BL	Blanco	18,38	18,38
I-191A-PB	Plata brillo	18,38	18,38
I-191A-PM	Plata mate	18,38	18,38
I-191A-NM	Negro mate	18,38	18,38



Escocias
Cove-Shaped

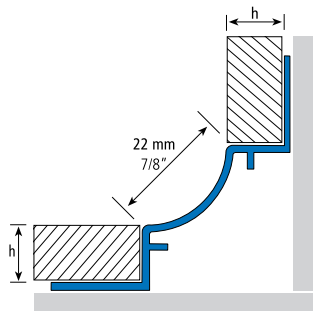
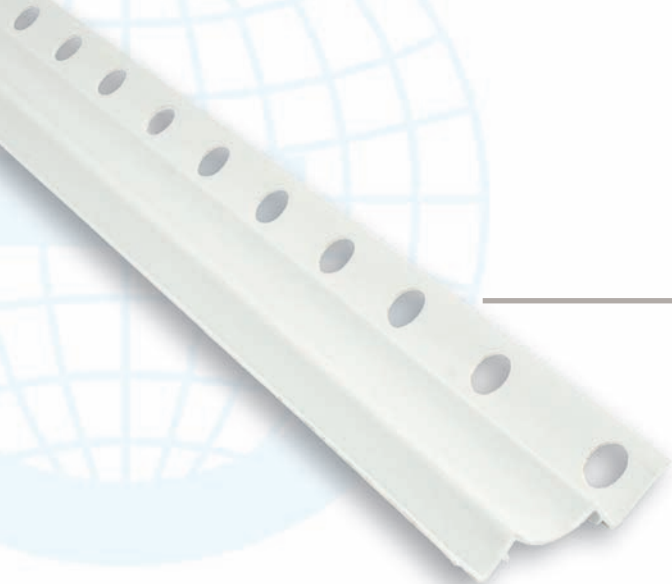

ES EUROESCOCIA-210, perfil de PVC utilizado para el ensamblaje del encuentro pared-suelo, así como para ángulos interiores entre paredes. Compensa los movimientos horizontales y verticales existentes entre la pared y el suelo. Este perfil cumple con las normativas de higiene y limpieza requeridas en la industria alimentaria, establecimientos sanitarios, etc.

La EUROESCOCIA-210 se ha de colocar durante el proceso de la obra y dispone de piezas especiales para ensamblar las esquinas entre dos o tres perfiles:

- **I-210:** Esquina interior.
- **E-210:** Esquina exterior.

EN EUROCOVE-210, PVC profile used to assemble the wall-floor joint and for inner wall angles. Compensates the horizontal and vertical movements existing between the wall and the floor.

This profile respects special sanitising and cleaning standards required by the food industry, hospitals, etc.

The EUROCOVE-210 should be installed during construction work and it has special connecting pieces for internal or external corners, these allow the connection between two or three profiles.

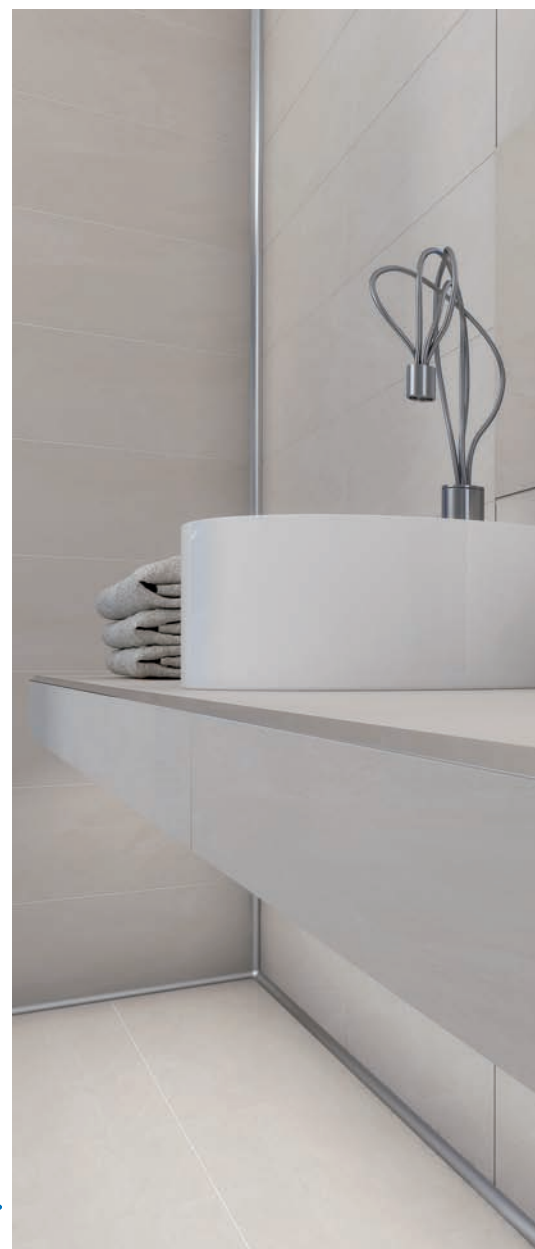

- **I-210:** Internal corner.
- **E-210:** External corner.



Longitud 2,55 m. Embalaje: 50 u/caja.

Length: 8,36 ft. Packing: 50 u/box.

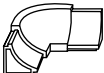
Precio/Price: € /perfil

Referencia Reference	Colores Colours		h: 10,5 mm 3/8"
210-BL	Blanco		6,47
210-GC	Gris claro		6,47
210-CR	Crema		6,47
	I-210 (esquina interior / internal corner)		Blister: 20 u.
I-210-BL	Blanco		2,61
I-210-GC	Gris claro		2,61
I-210-CR	Crema		2,61
	E-210 (esquina exterior / external corner)		Blister: 20 u.
E-210-BL	Blanco		2,73
E-210-GC	Gris claro		2,73
E-210-CR	Crema		2,73

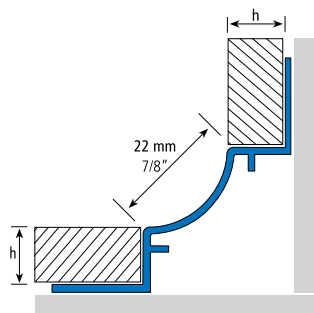
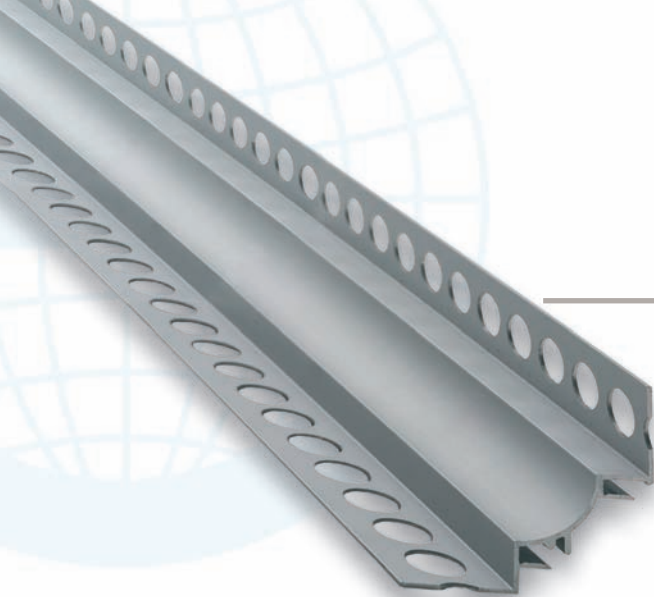

ES EUROESCOCIA-210A, perfil de aluminio utilizado para el ensamblaje del encuentro pared-suelo. Compensa los movimientos horizontales y verticales existentes entre la pared y el suelo. Este perfil cumple con las normativas de higiene y limpieza requeridas en la industria alimentaria, establecimientos sanitarios, etc. La EUROESCOCIA-210A se ha de colocar durante el proceso de la obra.

Este perfil dispone de piezas especiales para ensamblar las esquinas entre dos o tres vías:

- **I-210A**: Esquina interior • **I3W-210A**: Esquina interior tres vías
- **E-210A**: Esquina exterior • **F-210A**: Tapa final

EN EUROCOVE-210A, aluminium profile used to assemble the wall-floor joint and for inner wall angles. Compensates the horizontal and vertical movements existing between the wall and the floor. This profile respects special sanitising and cleaning standards required by the food industry, hospitals, etc. The EUROCOVE-210A should be installed during construction work.

This profile has special connecting pieces for internal or external corners, these allow the connection between two or three profiles:

- **I-210A**: Internal corner • **I3W-210A**: Internal corner three ways
- **E-210A**: External corner • **F-210A**: End cap



Escocias
Cove-Shaped

Longitud 2,50 m. Embalaje: 10 u/caja. Length: 8,2 ft. Packing: 10 u/box.

Precio/Price: € /perfil

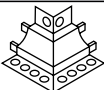
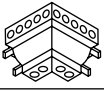
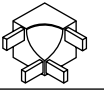
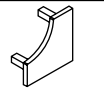
Referencia Reference	Colores Colours	h: 10 mm 3/8"
210A-BL	Blanco	25,61
210A-PM	Plata mate	25,55
 E-210A (esquina exterior / external corner)		Blister: 1 u.
E-210A-BL	Blanco	8,56
E-210A-PM	Plata mate	8,56
 I-210A (esquina interior dos vías / internal corner two ways)		Blister: 1 u.
I-210A-BL	Blanco	8,56
I-210A-PM	Plata mate	8,56
 I3W-210A (esquina interior tres vías / internal corner three ways)		Blister: 1 u.
I3W-210A-BL	Blanco	21,51
I3W-210A-PM	Plata mate	21,51
 F-210A (tapa final / end cap)		Blister: 1 u.
F-210A-BL	Blanco	11,76
F-210A-PM	Plata mate	11,76

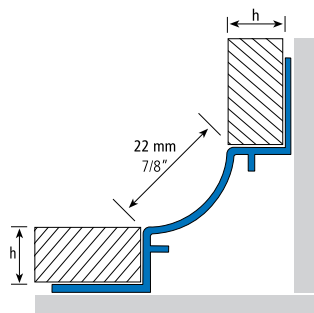
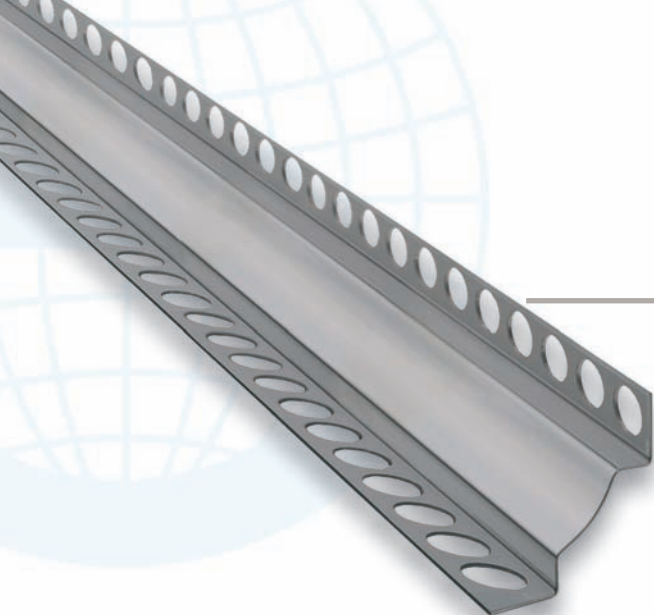

ES EUROESCOCIA-210S, perfil de Acero Inoxidable utilizado para el ensamble del encuentro pared-suelo. Compensa los movimientos horizontales y verticales existentes entre la pared y el suelo. Este perfil cumple con las normativas de higiene y limpieza requeridas en la industria alimentaria, establecimientos sanitarios, etc. La EUROESCOCIA-210S se ha de colocar durante el proceso de la obra.

Este perfil dispone de piezas especiales para ensamblar las esquinas entre dos o tres perfiles:

- **I-210S**: Esquina interior • **I3W-210S**: Esquina interior tres vías
- **E-210S**: Esquina exterior • **F-210S**: Tapa final

EN EUROCOTE-210S, Stainless Steel profile used to assemble the wall-floor joint and for inner wall angles. Compensates the horizontal and vertical movements existing between the wall and the floor. This profile respects special sanitising and cleaning standards required by the food industry, hospitals, etc. The EUROCOTE-210S should be installed during construction work.





This profile has special connecting pieces for internal or external corners, these allow the connection between two or three profiles:

- **I-210S**: Internal corner • **I3W-210S**: Internal corner three ways
- **E-210S**: External corner • **F-210S**: End cap

Longitud 2,50 m. Embalaje: 10 u/caja.

Length: 8,2 ft. Packing: 10 u/box.

Precio/Price: € /perfil

Referencia Reference	Colores Colours	h: 11 mm 7/16"
210S-IB	Inox brillo	37,23
210S-IC	Inox cepillado	37,23
	E-210S (esquina exterior / external corner)	Blister: 1 u.
E210S-IB	Inox brillo	4,97
E210S-IC	Inox cepillado	4,97
	I-210S (esquina interior dos vías / internal corner two ways)	Blister: 1 u.
I-210S-IB	Inox brillo	4,97
I-210S-IC	Inox cepillado	4,97
	I3W-210S (esquina interior tres vías / internal corner three ways)	Blister: 1 u.
I3W-210S-IB	Inox brillo	4,97
I3W-210S-IC	Inox cepillado	4,97
	F-210S (tapa final / end cap)	Blister: 1 u.
F-210S-IB	Inox brillo	4,97
F-210S-IC	Inox cepillado	4,97

Con film protector / With protective tape. / AISI-304



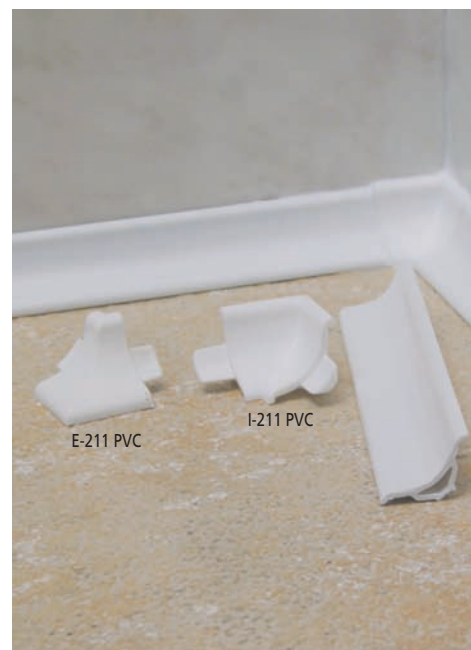
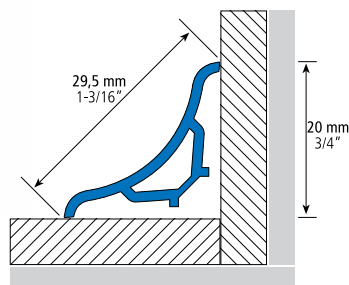

ES EUROESCOCIA-211, perfil de PVC utilizado para el ensamblaje del encuentro pared-suelo, así como para ángulos interiores entre paredes, uniones entre paredes y bañeras o platos de ducha, accesorios o superficies de baños y cocinas. Compensa los movimientos horizontales y verticales existentes entre la pared y el suelo. Este perfil cumple con las normativas de higiene y limpieza requeridas en la industria alimentaria, establecimientos sanitarios, ...

La EUROESCOCIA-211 se aplica con un cordón de silicona una vez finalizada la obra y dispone de piezas especiales para ensamblar las esquinas interiores y exteriores.

- **I-211**: Esquina interior.
- **E-211**: Esquina exterior.

EN EUROCOVE-211, PVC profile used to assemble the wall-floor joint, and for inner wall angles, unions between walls and fittings or tops in bathrooms and kitchens. Compensates the horizontal and vertical movements existing between the wall and the floor.



This profile respects special sanitising and cleaning standards required by the food industry, hospitals, etc. The EUROESCOCIA-211 is applied with a silicone bead once construction work is completed and it has special connecting pieces for internal or external corners, these allow the connection between two profiles:

- **I-211**: Internal corner.
- **E-211**: External corner.

Longitud 2,55 m. Embalaje: 100 u/caja.

Length: 8,36 ft. Packing: 100 u/box.

Precio/Price: € /perfil

Referencia Reference	Colores Colours	a: 29,5 mm h: 20 mm	1-3/16" 3/4"
211-BL	Blanco		6,01
211-GC	Gris claro		6,01
211-CR	Crema		6,01
 I-211 (esquina interior / internal corner)			Blister: 20 u.
I-211-BL	Blanco		2,54
I-211-GC	Gris claro		2,54
I-211-CR	Crema		2,54
 E-211 (esquina exterior / external corner)			Blister: 20 u.
E-211-BL	Blanco		2,65
E-211-GC	Gris claro		2,65
E-211-CR	Crema		2,65



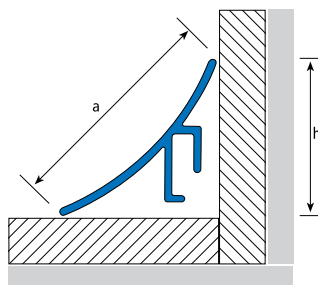

ES EUROESCOCIA-211A, perfil de aluminio utilizado para el ensamblaje del encuentro pared-suelo, así como para ángulos interiores entre paredes, uniones entre paredes y bañeras o platos de ducha, accesorios o superficies de baños y cocinas. Compensa los movimientos horizontales y verticales existentes entre la pared y el suelo. Este perfil cumple con las normativas de higiene y limpieza requeridas en la industria alimentaria, establecimientos sanitarios, ...

La EUROESCOCIA-211A se aplica con un cordón de silicona una vez finalizada la obra. Esta escocia dispone de piezas especiales para ensamblar las esquinas interiores y exteriores:

- **I-211A**: Esquina interior
- **I3W-211A**: Esquina interior tres vías
- **E-211A**: Esquina exterior
- **F-211A**: Tapa final



EN EUROCOVE-211A, aluminium profile used to assemble the wall-floor joint, and for inner wall angles, unions between walls and fittings or tops in bathrooms and kitchens. Compensates the horizontal and vertical movements existing between the wall and the floor.

This profile respects special sanitising and cleaning standards required by the food industry, hospitals, etc. The EUROCOVE-211A is applied with a silicone bead once construction work is completed. This reference has special connecting pieces for internal or external corners, these allow the connection between two profiles:

- **I-211A**: Internal corner
- **I3W-211A**: Internal corner three ways
- **E-211A**: External corner
- **F-211A**: End cap

Longitud 2,50 m. Embalaje: 10 u/caja. Length: 8,2 ft. Packing: 10 u/box.

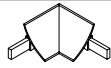
Precio/Price: € /perfil

Referencia Reference	Colores Colours	a: 16 mm h: 11 mm	5/8" 7/16"	a: 30 mm h: 20 mm	1-3/16" 3/4"	a: 50 mm h: 35 mm	2" 1-5/8"
211A-BL	Blanco		7,72		12,32		18,99
211A-PB	Plata brillo		9,56		15,50		
211A-PM	Plata mate		7,72		12,32		18,99
 E-211A (esquina exterior / external corner)						Blister: 1 u.	
E-211A-BL	Blanco		6,96		7,49		8,56
E-211A-PB	Plata brillo		6,96		7,49		
E-211A-PM	Plata mate		6,96		7,49		8,56
 I-211A (esquina interior / internal corner)						Blister: 1 u.	
I-211A-BL	Blanco		6,96		7,49		8,56
I-211A-PB	Plata brillo		6,96		7,49		
I-211A-PM	Plata mate		6,96		7,49		8,56
 I3W-211A (esquina interior tres vías / internal corner three ways)						Blister: 1 u.	
I3W-211A-BL	Blanco		18,19		19,26		22,47
I3W-211A-PB	Plata brillo		18,19		19,26		
I3W-211A-PM	Plata mate		18,19		19,26		22,47
 F-211A (tapa final / end cap)						Blister: 1 u.	
F-211A-BL	Blanco		12,01		12,01		13,30
F-211A-PB	Plata brillo		12,01		12,01		
F-211A-PM	Plata mate		12,01		12,01		13,30



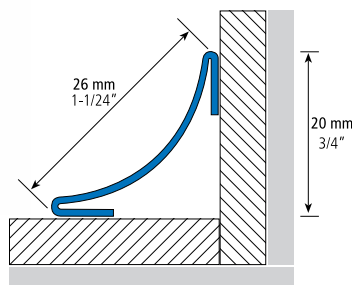

ES EUROESCOCIA-211S, perfil de acero inoxidable utilizado para el ensamblaje del encuentro pared-suelo, así como para ángulos interiores entre paredes, uniones entre paredes y bañeras o platos de ducha, accesorios o superficies de baños y cocinas. Compensa los movimientos horizontales y verticales existentes entre la pared y el suelo. Este perfil cumple las normativas de higiene y limpieza requeridas en la industria alimentaria, establecimientos sanitarios, ...

La EUROESCOCIA-211S se aplica con un cordón de silicona una vez finalizada la obra. Esta escocia dispone de piezas especiales para ensamblar las esquinas interiores y exteriores:

- **I-211S**: Esquina interior. • **I3W-211S**: Esquina interior tres vías
- **E-211S**: Esquina exterior

EN EUROCOVE-211S, stanleiss steel profile used to assemble the wall-floor joint, and for inner wall angles, unions between walls and fittings or tops in bathrooms and kitchens. Compensates the horizontal and vertical movements existing between the wall and the floor.

This profile respects special sanitising and cleaning standards required by the food industry, hospitals, etc. The EUROCOVE-211S is applied with a silicone bead once construction work is completed. This reference has special connecting pieces for internal or external corners, these allow the connection between two profiles:

- **I-211S**: Internal corner. • **I3W-211S**: Internal corner three ways
- **E-211S**: External corner





Escocias
Cove-Shaped

Longitud 2,50 m. Embalaje: 20 u/caja.

Lenght: 8,2 ft. Packing: 20 u/box.

Precio/Price: € /perfil

Referencia Reference	Colores Colours	a: 26 mm h: 20 mm	1-1/4" 3/4"
211S-IB	Inox brillo		26,71
211S-IC	Inox cepillado		26,71
	E-211S (esquina exterior / external corner)		Blister: 1 u.
E211S-IB	Inox brillo		4,97
E211S-IC	Inox cepillado		4,97
	I-211S (esquina interior dos vías / internal corner two ways)		Blister: 1 u.
I-211S-IB	Inox brillo		4,97
I-211S-IC	Inox cepillado		4,97
	I3W-211S (esquina interior tres vías / internal corner three ways)		Blister: 1 u.
I3W-211S-IB	Inox brillo		4,97
I3W-211S-IC	Inox cepillado		4,97

Con film protector / Whit protective tape. / AISI-304

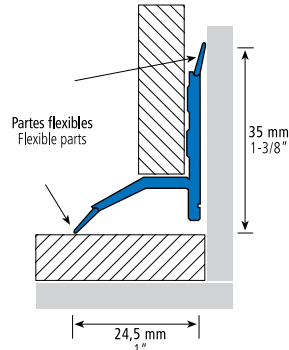

ES EUROBAÑERA-114, perfil de cierre flexible para el ensamblaje de revestimientos cerámicos con bañeras o platos de ducha, previniendo e impidiendo la penetración del agua entre estos y la pared. La EUROBAÑERA-114 se coloca durante el proceso de realización de la obra, por lo que garantiza la impermeabilización total de la zona. Perfil de PVC de alta resistencia al paso del tiempo y de fácil limpieza.

EN EUROBATH-114, flexible close profile for assembly of ceramic tile with baths, shower stalls, it prevents the water get into these and the wall. The EUROBATH-114, is applied during the construction work, to grants the waterproofing of the zone. PVC profile with high resistance to the pass of the time and easy to clean.



Longitud 2 m. Embalaje: 100 u/caja.
Length: 6,56 ft. Packing: 100 u/box.

Precio/Price: € /perfil

Referencia Reference	Colores Colours	
114- BL	Blanco	3,19

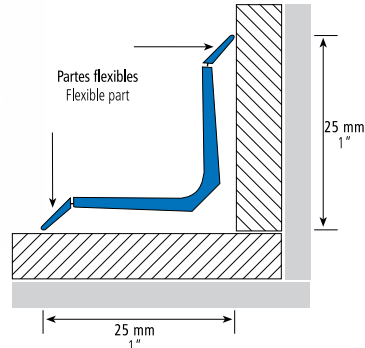
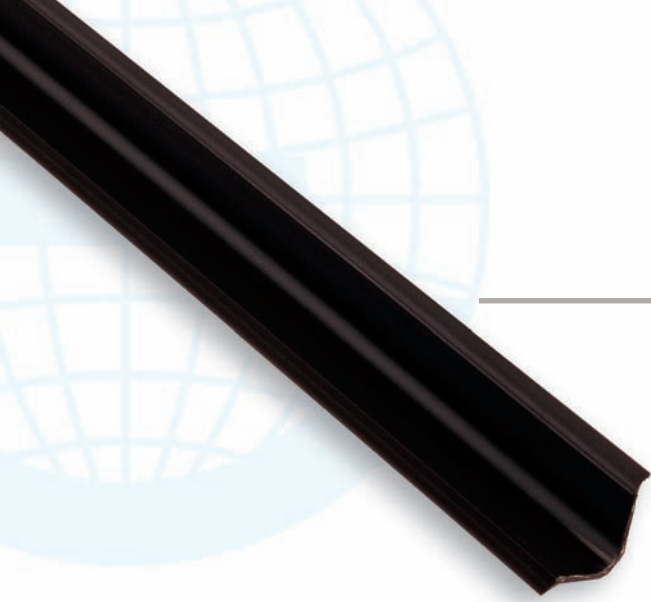

ES EUROBAÑERA-154, perfil de cierre flexible para el ensamblaje de revestimientos cerámicos con piezas de montaje que tengan contacto con el agua, como por ejemplo bañeras, platos de ducha, encimeras, etc. La EUROBAÑERA-154 se coloca con un cordón de silicona una vez finalizada la obra para prevenir la penetración del agua entre las dos superficies consiguiendo una impermeabilización total de la zona. Perfil de PVC de alta resistencia al paso del tiempo, fácil de colocar y de limpiar.

EN EUROBATH-154, flexible close profile for assembly of ceramic tile with assembly parts in contact with water, like baths, shower stalls, worktops, etc. The EUROBATH-154 is applied with a silicone bead once construction work is completed, to prevent that the water get into the two surfaces, to grants the total waterproofing of the zone. PVC profile with hight resistance to the pass of the time and easy to clean.



Escocias
Cove-Shaped

Longitud 2 m. Embalaje: 100 u/caja.

Lenght: 6,56 ft. Packing: 100 u/box.

Precio/Price: € /perfil

Referencia Reference	Colores Colours	
154- BL	Blanco	2,38
154 - CR	Crema	2,38





LED
LED

Perfiles para LED, diseñados para destacar, enmarcar e iluminar la superficie de las paredes obteniendo una luz suave y agradable, así como su uso en peldaños, nos ilumina la zona de pisada proporcionando un extra de seguridad.

LED profiles to highlight, frame, and illuminate the surface of walls for a smooth and pleasant light. Works especially well with steps, lighting the tread surface and providing extra safety.

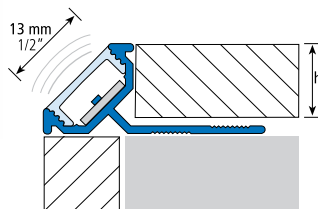

▲ no incluye LED / does not include LED

ES EUROCANTO LED-300A, Perfil destinado a esquinas exteriores en revestimientos cerámicos, tanto en pared como en bancadas o estantes. EUROCANTO de aluminio anodizado para LED, con cubierta extraíble de policarbonato blanca translúcida, que facilita la dispersión y homogeniza la luz. Con el EUROCANTO LED 300A podrá dotar a cualquier espacio de un acabado espectacular, que ilumina la superficie cerámica con una luz ambiental suave y agradable. Con el EUROCANTO LED 300A se abre un gran abanico de posibilidades en cuanto a iluminación decorativa y ambiental en baños, cocinas o cualquier espacio acabado con revestimiento, que proporciona importancia y remarca puntos de las estancias que antes era imposible iluminar.

Para zonas húmedas es aconsejable utilizar LED de protección IP65

Disponible referencia **F-300A**: tapa final.

ATENCIÓN: no incluye tira LED

EN EUROCORNER LED-300A, A profile designed for use on exterior corners with ceramic claddings, either for walls, benches, or shelves. The anodised aluminium EUROCORNER for LEDs, with a removable white translucent cover, allowing the light to be evenly spread. Using the EUROCORNER LED 300A, any space can be endowed with a spectacular finish, lighting the ceramic surface with a pleasant and gentle ambient light. The EUROCORNER LED 300A opens a huge range of possibilities in terms of decorative and ambient lighting in bathrooms, kitchens, or any space finished with facing, which can lend importance and emphasise points of a room that were previously impossible to light.

It is recommended to use LEDs with IP65 protection for damp areas.

Reference **F-300A** available: end cover.

ATTENTION: does not include LED strip

Longitud 2,50 m. Embalaje: 10 u/caja.

Length: 8,2 ft. Packing: 10 u/box.

Referencia Reference	Colores Colours	h: 12,5 mm 1/2"
300A-PB	Plata Brillo	34,86
300A-PM	Plata mate	31,30
	F-300A (Tapa final / End cap)	Blister: 1 u.
F-300A-PB	Plata Brillo	9,00
F-300A-PM	Plata mate	9,00

▲ **ATENCIÓN:** no incluye tira LED / **ATTENTION:** does not include LED strip

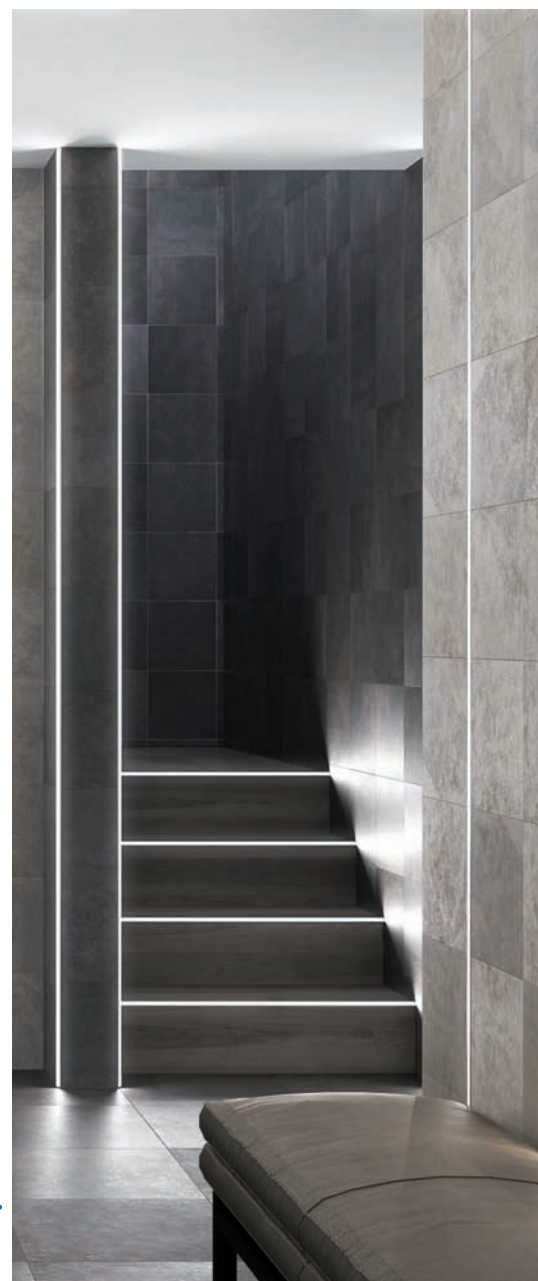

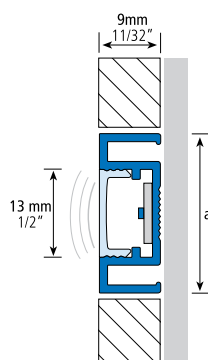

▲ no incluye LED / does not include LED

ES EUROLISTELO LED-301A, Innovador listelo diseñado para ser usado con tecnología LED, que nos proporciona grandes posibilidades en cuanto a iluminación decorativa en baños, cocinas o cualquier estancia acabada con revestimiento. Para destacar, enmarcar e iluminar la superficie de las paredes obteniendo una luz suave y agradable. A destacar su uso en peldaños, nos ilumina la zona de pisada proporcionando un extra de seguridad. El EUROLISTELO 301A de aluminio anodizado con parte vista de 23 mm, posee un diseño elegante que armoniza en cualquier ambiente. Ha sido desarrollado para proporcionar un agarre perfecto con cualquier tipo de adhesivo, que nos facilitará el poder remover la pantalla de policarbonato blanca traslúcida si es necesario. Para zonas húmedas es aconsejable utilizar LED de protección IP65
ATENCIÓN: no incluye tira LED



EN EUROLISTELO LED-301A, An innovative listello designed to be used with LED technology, which gives us huge possibilities in terms of decorative lighting in bathrooms, kitchens, or any room finished with facing. To highlight, frame, and illuminate the surface of walls for a smooth and pleasant light. Works especially well with steps, lighting the tread surface and providing extra safety. The anodised aluminium EUROLISTELLO-301A with 23 mm visible, is elegantly styled to blend into any environment. It has been developed to provide perfect attachment with any kind of adhesive, allowing us to be able to remove the white translucent polycarbonate screen if necessary. It is recommended to use LEDs with IP65 protection for damp areas.
ATTENTION: does not include LED strip



LED
LED

Longitud 2,50m. Embalaje: 10 u/caja.
Length 8,2 ft. Packing: 10 u/box.

Precio/Price: € /perfil

Referencia Reference	Colores Colours	h: 12 mm 1/2"
301A-PB	Plata brillo	34,86
301A-PM	Plata mate	31,30
new 301A-NM	Negro mate	38,50
	F-301A (Tapa final / End cap) Blister: 1 u.	
F-301A-PB	Plata brillo	11,76
F-301A-PM	Plata mate	11,76
new F-301A-NM	Negro mate	12,76
	ES90-301A (Esquina espejo 90° / 90° mirror corner) Blister: 1 u.	
ES90-301A-PB	Plata brillo	10,50
ES90-301A-PM	Plata mate	10,50
new ES90-301A-NM	Negro mate	11,50
	E-301A (Esquina exterior / External corner) Blister: 1 u.	
E-301A-PB	Plata brillo	10,50
E-301A-PM	Plata mate	10,50
new E-301A-NM	Negro mate	11,50

▲ **ATENCIÓN:** no incluye tira LED / **ATTENTION:** does not include LED strip

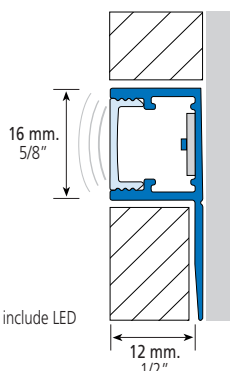
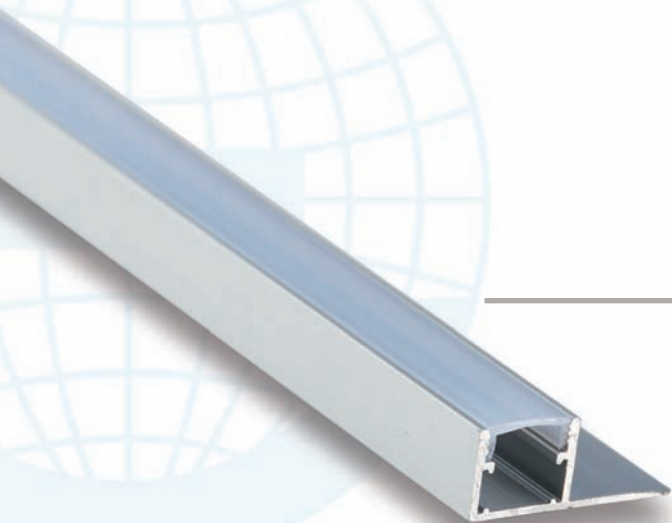

⚠ no incluye LED / does not include LED

ES EUROMULTIUSOS-302A, perfil LED para múltiples usos: listelo decorativo, cantonera, remate en suelos y paredes, peldaños, separador, ... Multiusos de aluminio con pantalla de policarbonato removible, de gran versatilidad, diseñado para ser usado con tecnología LED, que nos aporta grandes posibilidades en cuanto a iluminación decorativa; para destacar, enmarcar e iluminar las superficies con una luz suave y agradable.

Para su uso en zonas húmedas es aconsejable utilizar LED de protección IP65.

Disponibles piezas especiales: **E-302A**: esquina exterior, **F-302A**: tapa final.

ATENCIÓN: no incluye tira LED.

EN EUROMULTIPURPOSE-302A, Multi-use LED profile: decorative listello, corner piece, for floors and walls, steps, separator... Multi-use aluminium with detachable polycarbonate cover, very versatile, designed to be used with LED technology, providing lots of possibilities in terms decorative illuminations; to highlight, define and illuminate surfaces with a soft and pleasant light.

If using in damp areas, the use of IP65-protected LEDs is advisable.

Special parts available: **E-302A**: exterior corner, **F-302A**: end cover.



ATTENTION: does not include LED strip.



Longitud 2,50m. Embalaje: 10 u/caja..

Length 8,2 ft. Packing: 10 u/box.

Precio/Price: € /perfil

Referencia Reference	Colores Colours	h: 12 mm 1/2"
302A-PM	Plata mate	34,86
	F-302A (Tapa final / End cap)	Blister: 1 u.
F-302A-PM	Plata mate	9,00
	E-302A (Esquina exterior / External corner)	Blister: 1 u.
E-302A-PM	Plata mate	10,50

⚠ **ATENCIÓN:** no incluye tira LED / **ATTENTION:** does not include LED strip

New

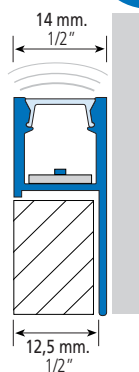

⚠ no incluye LED / does not include LED

ES EUROMULTIUSOS 303A, perfil de aluminio multiusos para uso con tecnología LED. Diseñado para una colocación como remate final de revestimiento, proporciona una luz indirecta de ambiente o señalización de manera funcional. Pantalla de policarbonato extraíble. Para uso en zonas húmedas recomendamos el uso de nuestros LED IP65.

EN EUROMULTIPURPOSE 303A, a multi-purpose aluminum profile for use with LED technology. Designed for use as a final coat finish, it provides indirect ambient light or signaling in a functional manner. Removable polycarbonate screen. We recommend our IP65 LEDs for use in moist areas.



LED
LED

Longitud 2,50m. Embalaje: 10 u/caja.
Length 8,2 ft. Packing: 10 u/box.

Precio/Price: € /perfil

Referencia Reference	Colores Colours	h: 12,5 mm 1/2"
303A-PM	Plata mate	34,86
	F-303A (Tapa final / End cap)	
F-303A-PM	Plata mate	Blister: 1 u. 10,50

⚠ **ATENCIÓN:** no incluye tira LED / **ATTENTION:** does not include LED strip



Soluciones LED
para Peldaños
Stair-Nosing LED Solutions

ALUMINIO / ALUMINIUM

305A

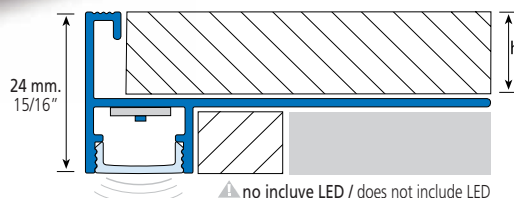

ES EUROPELDAÑO LED-305A, peldaño diseñado para ser usado con tecnología LED. Proporciona una iluminación indirecta para destacar e iluminar cualquier escalón, decorando y a la vez proporcionando un extra en seguridad al hacerlo más visible. La pantalla blanca traslúcida de policarbonato es removible. El Europeldaño 305A, se coloca durante el proceso de la obra.

Disponible piezas especiales: **E-305A**: esquina exterior, **F-305A**: tapa final.

ATENCIÓN: no incluye tira LED.

EN EUROSTEP LED-305A, a step designed to be used with LED technology. Provides an indirect light to highlight and illuminate any step, whilst also adding a decorative touch and providing extra security by making it more visible. The white translucent polycarbonate screen is removable. The Eurostep 305A is placed during the work process.

Special parts available: **E-305A**: exterior corner, **F-305A**: end cover.

ATTENTION: does not include LED strip.



Longitud 2,50 m. Embalaje: 10 u/caja.

Length: 8,2 ft. Packing: 10 u/box.

Precio/Price: € /perfil

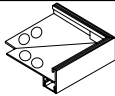
Referencia Reference	Colores Colours	h: 12 mm 1/2"
305A-PM	Plata mate	48,00
	F-305A (Tapa final / End cap)	Blister: 1 u.
F-305A-PM	Plata mate	9,00
	E-305A (Esquina exterior / external corner)	Blister: 1 u.
E-305A-PM	Plata mate	15,00

⚠ **ATENCIÓN:** no incluye tira LED / **ATTENTION:** does not include LED strip



New

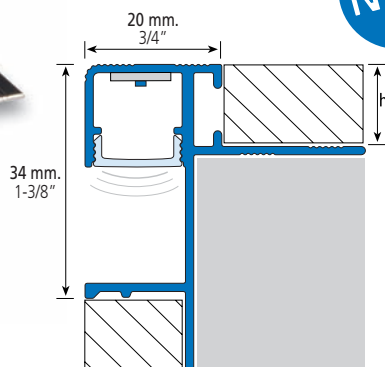
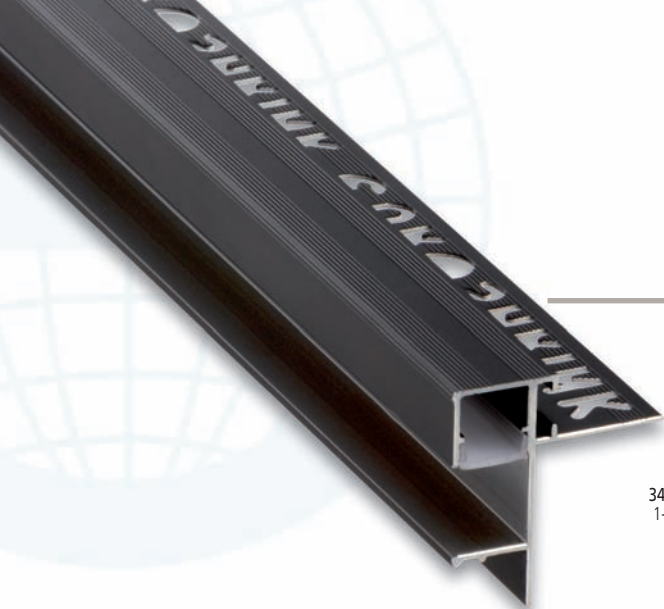

▲ no incluye LED / does not include LED

ES UROPELDAÑO-306A, Peldaño de aluminio antideslizante para uso con tecnología LED. Proporciona una iluminación elegante e indirecta que queda resguardada en su propio cajón. Este ha sido diseñado para que el pavimento vertical del escalón quede al mismo nivel que el frontal del peldaño.

Pantalla de policarbonato extraíble.

Para uso en zonas húmedas recomendamos el uso de nuestros LED IP65.

Disponibles piezas especiales: • **FD-306A**: tapa final derecha • **FI-306A**: tapa final izquierda • **E-306A**: esquina exterior

EN UROSTEP-306A, A non-slip aluminum step for use with LED technology. It provides sophisticated, indirect lighting stored in its own drawer. It has been designed to ensure the vertical paving of the step is on the same level as the front of the step.

Removable polycarbonate screen.

We recommend our IP65 LEDs for use in moist areas.

Special parts available: • **FD-306A**: right end cap • **FI-306A**: left end cap • **E-306A**: outer corner.





LED
LED

Longitud 2,50m. Embalaje: 10 u/caja.

Length 8,2 ft. Packing: 10 u/box.

Precio/Price: € /perfil

Referencia Reference	Colores Colours	h: 12 mm 1/2"
306A-PM	Plata mate	54,00
306A-NM	Negro mate	59,00
	E-306A (Esquina exterior / External corner)	
		Blister: 1 u.
E-306A-PM	Plata mate	17,00
E-306A-NM	Negro mate	19,00
	FI-306A (Tapa final Izquierda / Left end cap)	
		Blister: 1 u.
FI-306A-PM	Plata mate	11,86
FI-306A-NM	Negro mate	11,86
	FD-306A (Tapa final derecha / Right end cap)	
		Blister: 1 u.
FD-306A-PM	Plata mate	11,86
FD-306A-NM	Negro mate	11,86

▲ **ATENCIÓN:** no incluye tira LED / **ATTENTION:** does not include LED strip

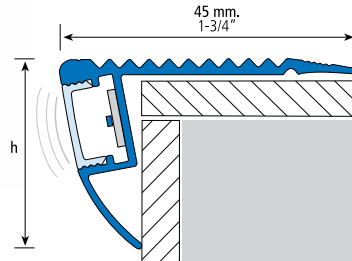
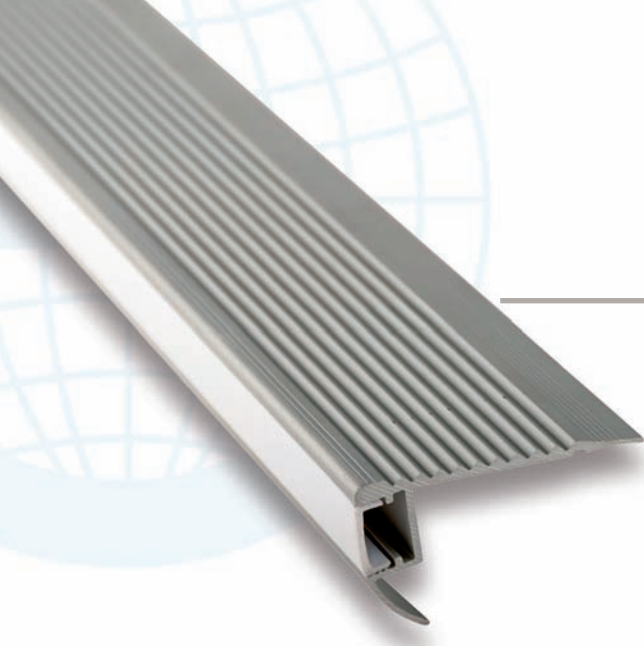

⚠ no incluye LED / does not include LED

ES EUROPELDAÑO LED-310A, peldaño antideslizante diseñado para ser usado con tecnología LED. Proporciona una iluminación frontal tenue para destacar e iluminar cualquier escalón, decorando y a la vez proporcionando un extra en seguridad al hacerlo más visible. La pantalla blanca traslúcida de policarbonato es removible. El EUROPELDAÑO-310A, se coloca una vez finalizada la obra. Disponible referencia **F-310A**: tapa final.
ATENCIÓN: no incluye tira LED.

EN EUROSTEP LED-310A, non-slip step designed to be used with LED technology. Provides a dim frontal light to highlight and illuminate any step, whilst also adding a decorative touch and providing extra security by making it more visible. The white translucent polycarbonate screen is removable. The EUROSTEP-310A is placed once the work is complete. Reference **F-310A** available: end cover.
ATTENTION: does not include LED strip

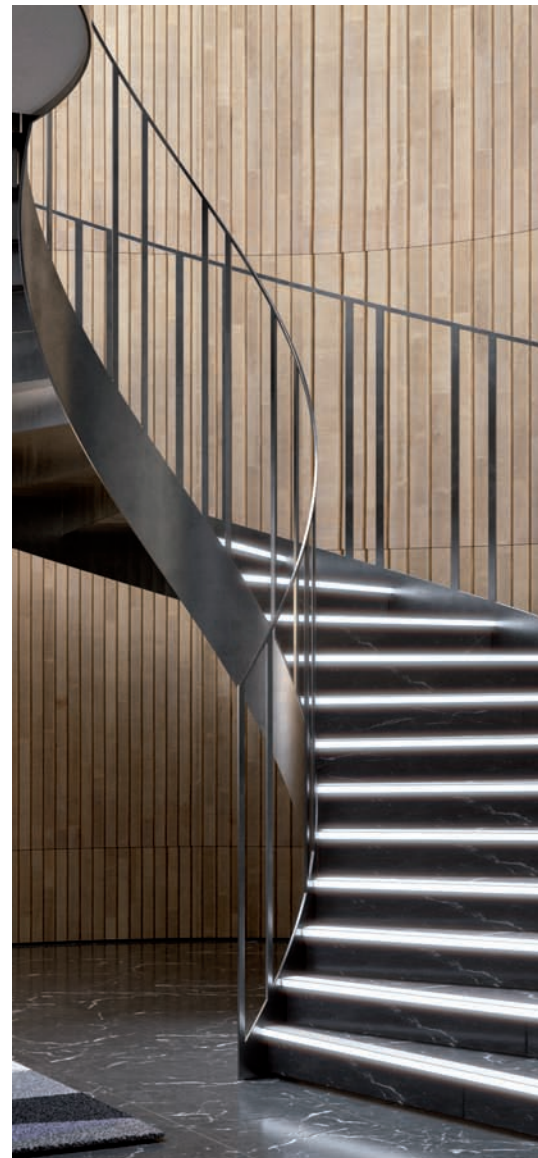

Longitud 2,50 m. Embalaje: 10 u/caja.

Length: 8,2 ft. Packing: 10 u/box.

Precio/Price: € /perfil

Referencia Reference	Colores Colours	a: 45 mm 1-3/4" h: 28,5 mm 1-1/8"
310A-PM	Plata mate	47,50
	F-310A (Tapa final / End cap)	
F-310A-PM	Plata mate	Blister: 1 u. 9,00

⚠ **ATENCIÓN:** no incluye tira LED / **ATTENTION:** does not include LED strip

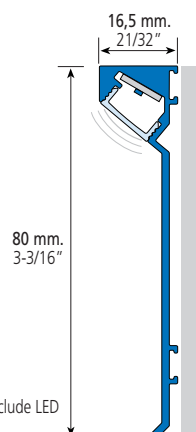

⚠ no incluye LED / does not include LED

ES EUROZOCALO-320A, Zócalo de aluminio de sección recta para su uso con tecnología LED. Perfil de 2,5 m. de longitud de rápida colocación con silicona. La pantalla de policarbonato removible, tras la cuál se coloca la tira LED, está inclinada hacia el suelo proporcionando una luz indirecta y suave, que a la vez que decora actúa como elemento de señalización.

Para su uso en zonas húmedas es aconsejable utilizar LED de protección IP65.

Disponibles piezas especiales: • **I-320A**: Esquina interior • **E-320A**: Esquina exterior • **F-320A**: Tapa final

ATENCIÓN: no incluye LED

EN EUROSKIRTING-320A, Straight aluminium plinth panel for use with LED technology. 2,5 m. long profile for quick installation with silicon. The detachable polycarbonate cover, behind which the LED strip is placed, leans towards the floor, providing an indirect and soft light, which has decorative as well as signalling purposes.

If using in damp areas, the use of IP65-protected LEDs is advisable.

Special parts available: • **I-320A**: Internal corner. • **E-320A**: External corner • **F-320A**: End cap

WARNING: does not include LED

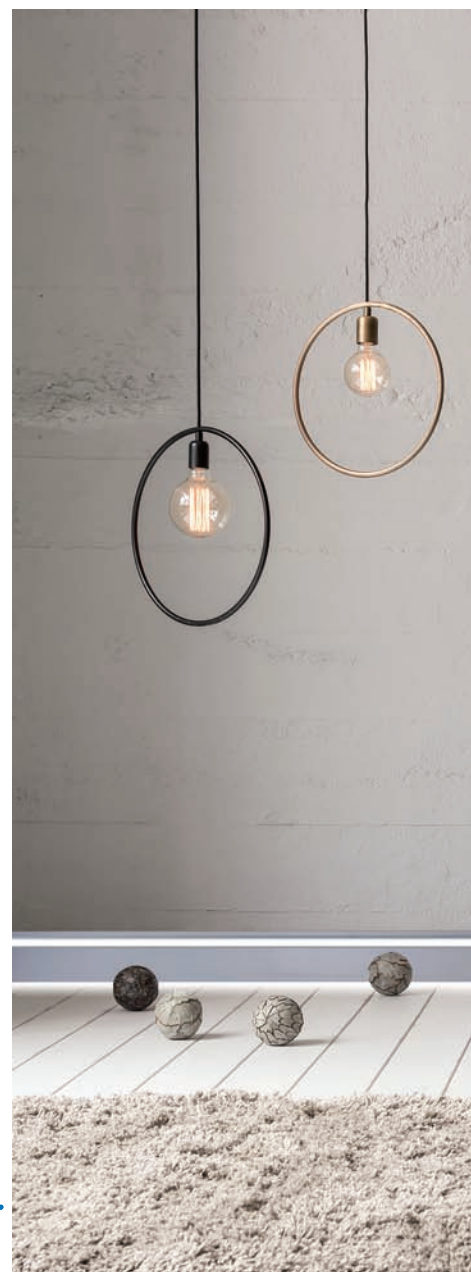



LED
LED

Longitud 2,50m. Embalaje: 10 u/caja.

Length 8,2 ft. Packing: 10 u/box.

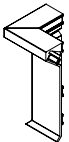
Precio/Price: € /perfil

Referencia Reference	Colores Colours	h: 80 mm 3-3/16"
320A-PM	Plata mate	59,00
	F-320A (Tapa final / End cap)	Blister: 1 u.
F-320A-PM	Plata mate	12,00
	E-320A (Esquina exterior / External corner)	Blister: 1 u.
E-320A-PM	Plata mate	15,00
	I-320A (Esquina interior / Internal corner)	Blister: 1 u.
I-320A-PM	Plata mate	15,00

⚠ **ATENCIÓN:** no incluye tira LED / **ATTENTION:** does not include LED strip

New



ES Gama de soluciones y accesorios LED de Euroshrink: Tiras de LED de luz cálida, fría o multicolor RGB; transformadores, controladores y conexiones rápidas.

EN The Euroshrink range of LED solutions and accessories: warm, cold or multi-colour RGB LED strip lights; transformers, controllers and quick connections.

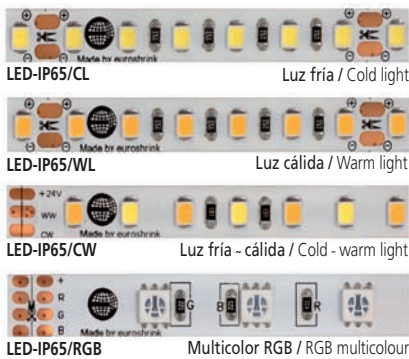

EuroLED-IP65

Referencia Reference	Descripción Description	Longitud Leight	u./Caja u./Box	Precio/Price: €/u.
LED - IP65/5CL	Euroled IP65. COLD LIGHT. 6500K. 120Led/M. 6W/M. DC24V. a: 8 mm.	5 m.	10	56,17
LED - IP65/10CL	Euroled IP65. COLD LIGHT. 6500K. 120Led/M. 6W/M. DC24V. a: 8 mm.	10 m.	10	112,35
LED - IP65/5WL	Euroled IP65. WARM LIGHT. 3000K. 120Led/M. 6W/M. DC24V. a: 8 mm	5 m.	10	56,17
LED - IP65/5CW	Euroled IP65. COLD ~ WARM LIGHT. 6500 ~ 2700K. 120Led/M. 6W/M. DC24V. a: 8 mm.	5 m.	10	68,00
LED - IP65/5RGB	Euroled IP65. MULTICOLOR RGB. 60Led/M. 10W/M. DC24V. a: 10 mm.	5 m.	10	91,65

⚠ ATENCIÓN: Asegurarse de que la potencia de la tira LED es adecuada a la potencia del transformador.
ATTENTION: Make sure the power of the LED strip light is consistent with the power of the transformer.

Eurotransformador TR-IP67



Referencia Reference	Descripción Description	u./Caja u./Box	Precio/Price: €/u.
TR-IP67/40W	Eurotransformador IP67. 40W. 24DC.	10	39,53
TR-IP67/75W	Eurotransformador IP67. 75W. 24DC.	10	59,30
TR-IP67/150W	Eurotransformador IP67. 150W. 24DC.	10	87,54

⚠ ATENCIÓN: Los LED no deben exceder el 90% de la potencia del transformador.
ATTENTION: LEDs must not exceed 90% of the power of the transformer.

Eurocontrol LED



Referencia Reference	Descripción Description	u./Caja u./Box	Precio/Price: €/u.
CONTROLLED	Eurocontrol LED TOUCH. 12/24V. Max 432W.	10	39,79
CONTROLLED/CW	Eurocontrol LED TOUCH CW. COLD ~ WARM LIGHT. 12/24V. Max 288W.	10	39,79
CONTROLLED/RGB	Eurocontrol LED RGB. WIFI. 12/24V. Max 288W.	10	42,10

⚠ ATENCIÓN / ATTENTION
CONTROLLED: Válido para LED-IP65/CL y LED-IP65/WL / Valid for LED-IP65/CL y LED-IP65/WL
CONTROLLED/CW: Válido para LED-IP65/CW / Valid for LED-IP65/CW
CONTROLLED/RGB: Válido para LED-IP65/RGB / Valid for LED-IP65/RGB

Euroconector



Referencia Reference	Descripción Description	u./Caja u./Box	Precio/Price: €/u.
C-2PIN/L+C	Euroconector 2PIN. Para LED IP65/CL y IP65/WL - 8mm. LED + Cable	10	1,98
C-2PIN/L+L	Euroconector 2PIN. Para LED IP65/CL y IP65/WL - 8mm. LED + LED	10	1,98
C-4PIN/L+C	Euroconector 4PIN. Para LED IP65/RGB - 10mm. LED + Cable	10	2,15
C-4PIN/L+L	Euroconector 4PIN. Para LED IP65/RGB - 10mm. LED + LED	10	2,15

⚠ ATENCIÓN / ATTENTION Los conectores no se pueden insertar dentro de los Europerfiles LED / Can not be inserted into EuroLED profiles
C-2PIN Válido para LED-IP65/CL y LED-IP65/WL / Valid for LED-IP65/CL y LED-IP65/WL
C-4PIN Válido para LED-IP65/RGB / Valid for LED-IP65/RGB



Los Eurovierteaguas están desarrollados para evitar el goteo sobre la pared a la vez que proporciona una excelente protección de la cerámica en balcones o repisas exteriores. Estos perfiles se complementan con piezas especiales para el remate de las esquinas interiores y exteriores.

Our Eurobalconies were developed to avoid water from dripping on the walls and at the same time to provide an excellent protection of balconies with ceramic cladding and outside cornices. These profiles have special pieces that can be used to finish up inner and outer corners.

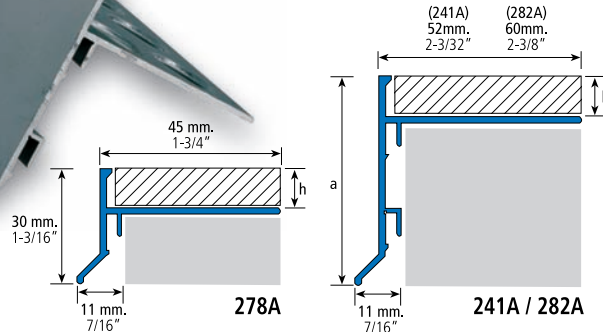

ES EUROVIERTEAGUAS, perfil de aluminio de canto recto destinado a la protección de la cerámica en balcones o repisas exteriores. Colocado durante la obra proporciona el remate perfecto para evitar el goteo sobre la superficie vertical, evitando manchas antiestéticas en las paredes.

El EUROVIERTEAGUAS se suministra con piezas de unión para una perfecta colocación.

Este perfil dispone de piezas especiales para ensamblar las esquinas interiores y exteriores:

- I: Esquina interior
- E: Esquina exterior

EN EUROBALCONY, This aluminium profile possesses a straight edge and is intended for the protection of ceramic tiles on balconies or outside cornices. It is placed during the construction work and provides the perfect finishing in order to avoid dripping on vertical surfaces, and thus avoids unsightly stains on the walls.

This profile is supplied with joint pieces for a perfect positioning. This reference has special connecting pieces for internal or external corners, these allow the connection between two profiles:

- I: Internal corner
- E: External corner

Longitud 2,50 m. Embalaje: 10 u/caja.

Lenght: 8,2 ft. Packing: 10 u/box.

Precio/Price: € /perfil

Referencia Reference	Colores Colours	Ancho (a) Width (a)	h: 12 mm 1/2"
278A-PM	Plata mate	30 mm - 1-3/16"	23,16
241A-BL	Blanco	55 mm - 2-3/16"	38,79
241A-PM	Plata mate	55 mm - 2-3/16"	38,36
282A-PM	Plata mate	75 mm - 2-15/16"	55,00

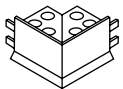

E- (esquina exterior / external corner)

Blister: 1 u.

E-278A-PM	Plata mate	30 mm - 1-3/16"	11,03
E-241A-BL	Blanco	55 mm - 2-3/16"	13,91
E-241A-PM	Plata mate	55 mm - 2-3/16"	13,91
E-282A-PM	Plata mate	75 mm - 2-15/16"	14,95

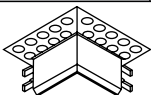

I- (esquina interior / internal corner)

Blister: 1 u.

I-278A-PM	Plata mate	30 mm - 1-3/16"	11,03
I-241A-BL	Blanco	55 mm - 2-3/16"	13,91
I-241A-PM	Plata mate	55 mm - 2-3/16"	13,91
I-282A-PM	Plata mate	75 mm - 2-15/16"	14,95

*COLORES
ESPECIALES
*SPECIALS
COLORS

*Arena antracita
*Arena oxido
*Arena negro

*Colores disponibles bajo pedido (No stock) Consultar precios
Colors available on request (No stock)

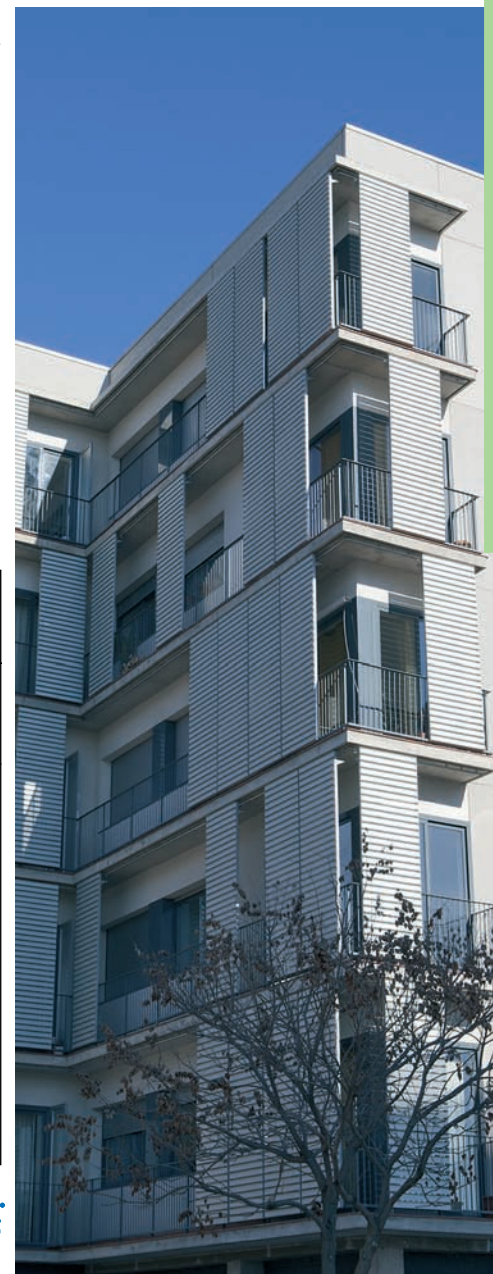
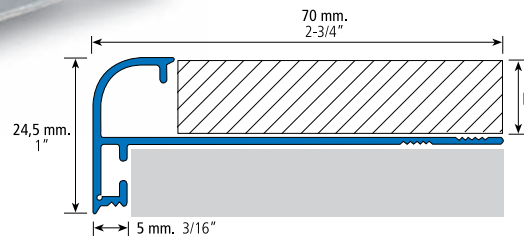
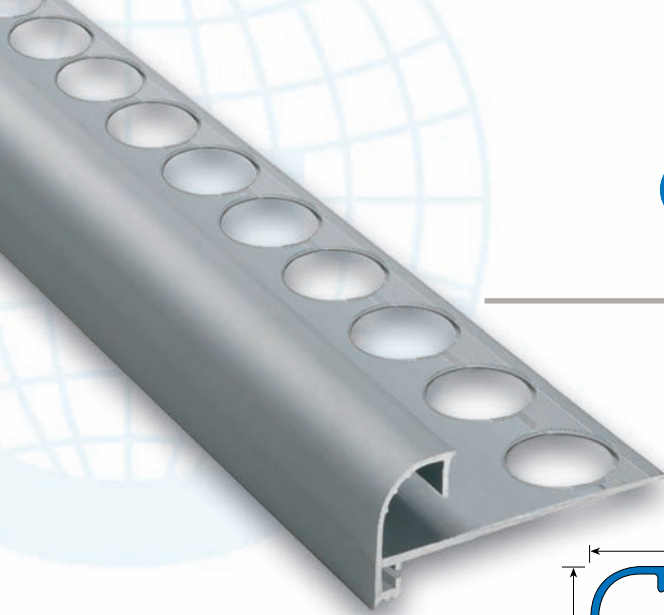

ES EUROVIERTEAGUAS-242A, perfil de aluminio de canto redondeado destinado a la protección de la cerámica en balcones o repisas exteriores. Colocado durante la obra proporciona el remate perfecto para evitar el goteo sobre la superficie vertical, evitando manchas antiestéticas en las paredes.

El EUROVIERTEAGUAS-242A se suministra con piezas de unión para una perfecta colocación. Este perfil dispone de piezas especiales para ensamblar las esquinas interiores y exteriores:

- **I-242A:** Esquina interior
- **E-242A:** Esquina exterior

EN EUROBALCONY-242A, This rounded edge aluminium profile is intended for the protection of ceramic tiles on balconies or outside cornices. It is placed during the construction work and it provides the perfect finishing in order to avoid dripping on vertical surfaces, and thus avoids unsightly stains on the walls.

This profile is supplied with joint pieces for a perfect positioning. This reference has special connecting pieces for internal or external corners, these allow the connection between two profiles:

- **I-242A:** Internal corner
- **E-242A:** External corner

Longitud 2,50 m. Embalaje: 10 u/caja.

Lenght: 8,2 ft. Packing: 10 u/box.

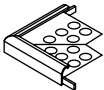
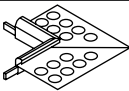
Referencia Reference	Colores Colours	h: 12,5 mm 1/2"
242A-BL	Blanco	28,98
242A-PM	Plata mate	28,68
 E-242A (esquina exterior / external corner)		Blister: 1 u.
E-242A-BL	Blanco	12,84
E-242A-PM	Plata mate	12,84
 I-242A (esquina interior / internal corner)		Blister: 1 u.
I-242A-BL	Blanco	12,84
I-242A-PM	Plata mate	12,84

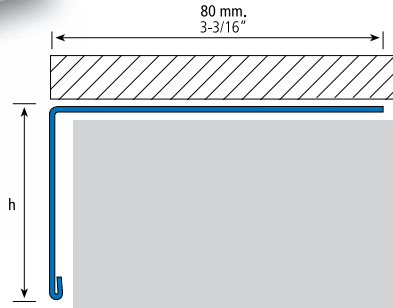
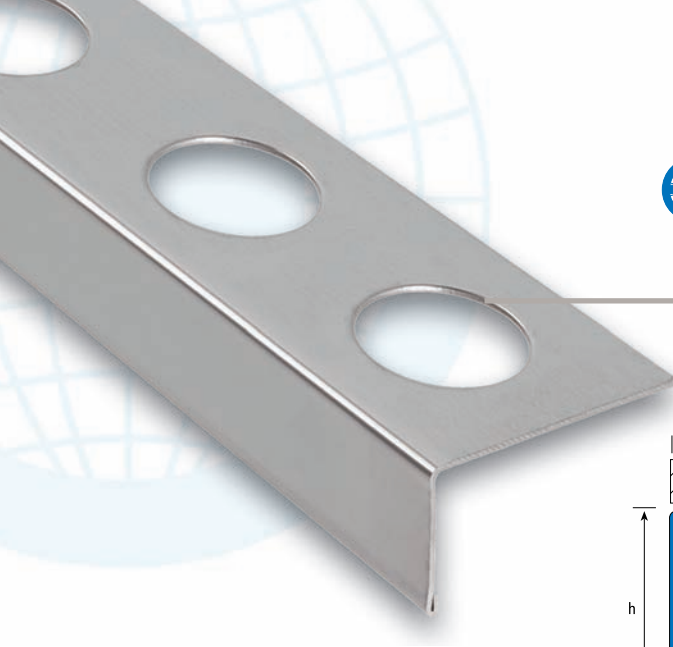

(A) Aluminio/Aluminium (S) Acero inoxidable / Stainless Steel

ES EUROVIERTEAGUAS, Perfil de aluminio o acero inoxidable en ángulo recto, diseñado para poder ser usado con diferentes espesores. Destinado a la protección y acabado de los bordes exteriores en balcones y terrazas, facilita que el agua de lluvia fluya sin entrar en contacto con las paredes verticales, evitando posibles filtraciones. El perfil dispone de piezas especiales para ensamblar:

- E: Esquina exterior.
- J: Unión entre los perfiles.



EN EUROBALCONY, Right-angled stainless steel or aluminium profile designed for use with different thicknesses. Intended for the protection and finish of the outer edges on balconies and terraces, it makes it easier for rainwater to flow without coming into contact with the vertical walls, avoiding any possible leaks. The profile is endowed with special parts for assembly:

- E: Outside corners
- J: Joint between profiles



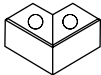

Aluminio - Longitud 2,50 m. Embalaje: 10 u/caja.

Aluminium - Length: 8,2 ft. Packing: 10 u/box.

Referencia Reference	Colores Colours		h: 55 mm 2-3/16"
280A-GR	Gris		45,41
 E-280A (esquina exterior / external corner)		 J-280A (unión / joint piece)	Blister: 1 u.
E-280A-GR	Gris		23,54
J-280A-GR	Gris		4,28

Acero inoxidable - Longitud 2,50 m. Embalaje: 10 u/caja.

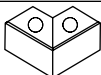
Stainless steel - Length: 8,2 ft. Packing: 10 u/box.

280S-IB	Inox brillo		60,26
 E-280S (esquina exterior / external corner)		 J-280S (unión / joint piece)	Blister: 1 u.
E-280S-IB	Inox brillo		26,09
J-280S-IB	Inox brillo		3,73



Zócalo elegante de fácil instalación para el remate.
Elegant skirting of easy installation for the finishing.



Sistema rápido, sencillo y seguro para la construcción de tabiques de bloques de vidrio.
Quick, simple and safe system for the construction of glass block partitions.

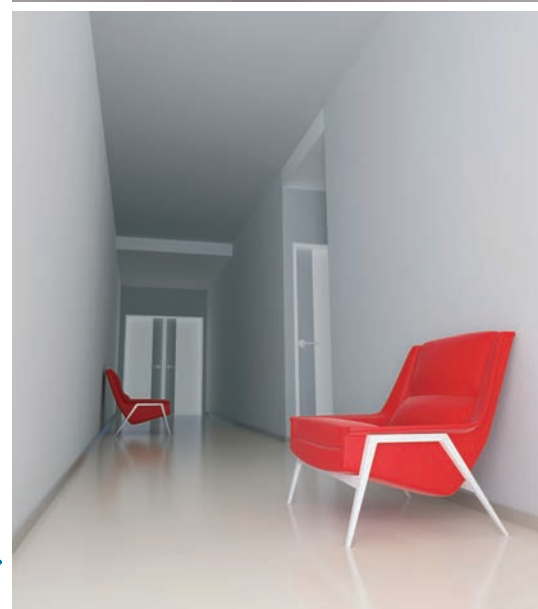
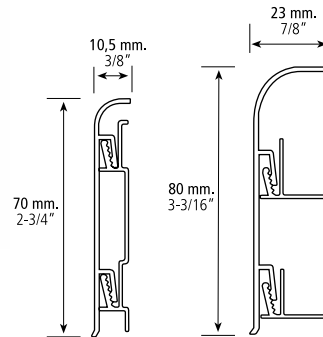
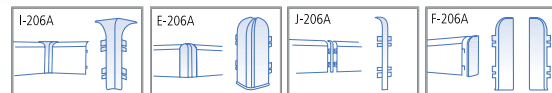

ES EUROZÓCALO-206A, zócalo fabricado en aluminio adaptándose a las nuevas tendencias en diseño y decoración. Se suministra con piezas para su fijación, que proporcionan una rápida colocación del perfil de 2 metros de longitud. Diseñado especialmente para ocultar los cables (teléfono, ordenador, equipos de música, etc.) que tan antiestéticos quedan en casa, oficinas y otras ubicaciones. Este perfil se complementa con piezas de PVC para esquinas interiores(I) y exteriores(E), de unión(J) y tapones finales(F) para poder obtener un acabado perfecto. El perfil se ha desarrollado en dos medidas, 70 mm y 80 mm, para adaptarse a todo tipo de usos: almacenes, oficinas, grandes superficies comerciales o públicas, casas particulares, etc. **MODO DE APLICACIÓN : 1) colocar piezas de fijación suministradas, a la pared mediante tornillos. 2) anclar el zócalo de 2 metros en las 3 piezas fijadas a pared previamente**

EN EUROSKIRTING-206A, skirting board produced with aluminium which adapts to the new design and decoration trends giving and elegance finishings. It is supplied with parts that help attach it so it can be fitted quickly into a stripping of 2 m. It was especially designed to hide cables (e.g. of telephones, computers, music systems, ...) that offer an unattractive sight of the house, office and other places. This profile is supplemented with PVC pieces for internal(I) and external(E) corners, joint(J) profiles and final tops(F) to obtain a perfect finishing. This profile has been developed with two measures, 70 mm and 80 mm., and thus adapt to all kinds of uses: stores, offices, big shopping centres or public areas, private houses, and so on. **HOW TO USE : 1) put the fixing supports at the wall with screws. 2) click the skirting of 2 m. over the fixing supports.**

Longitud 2 m. Embalaje: 10 u/caja Length: 6,56 ft. Packing: 10 u/box.

Referencia Reference	Colores Colours	h: 70 mm 2-3/4"		h: 80 mm 3-3/16"	
		a: 10,5 mm 3/8"		a: 23mm 7/8"	
206A-BL		30,27			
206A-PM		30,27		34,68	
206A-NO		37,31			
206A-RO		37,31			
E-206A (esquina exterior / external corner)				Blister: 1 u.	
E-206A-BL		2,95			
E-206A-PM		2,95		2,95	
E-206A-NO		2,95			
E-206A-RO		2,95			
I-206A (esquina interior / internal corner)				Blister: 1 u.	
I-206A-BL		2,95			
I-206A-PM		2,95		2,95	
I-206A-NO		2,95			
I-206A-RO		2,95			
J-206A (unión / joint piece)				Blister: 1 u.	
J-206A-BL		2,95			
J-206A-PM		2,95		2,95	
J-206A-NO		2,95			
J-206A-RO		2,95			
F-206A (tapones finales / end cap)				Blister: 2 u. (L & R)	
F-206A-BL		2,95			
F-206A-PM		2,95		2,95	
F-206A-NO		2,95			
F-206A-RO		2,95			

* El perfil de 2 m de longitud se suministra retráctilado individualmente con 3 piezas de fijación, tacos y tornillos. The stripping with a length of 2 m is supplied with 3 fixing supports, plugs and screws, and completely shrink-wrapped in a full package.

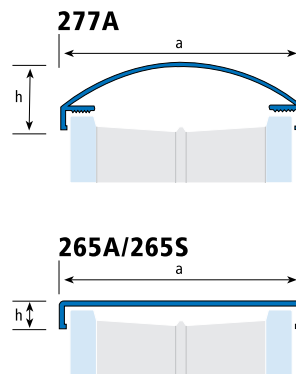
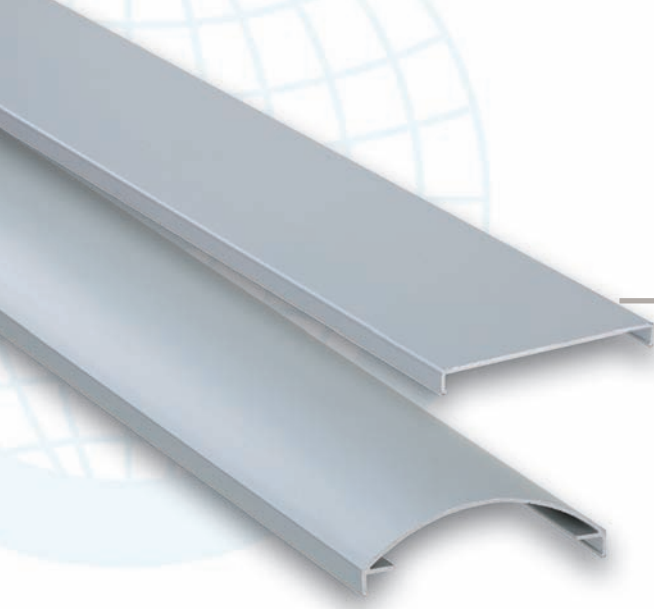

ES EUROCANTO, Perfil de para el remate final de paredes de bloque de vidrio, proporcionando protección al canto y elegancia a la pared.

EN EUROCORNER, Profile for the final finish on glass block walls, providing the edge with protection and making the wall look elegant.

Aluminio - Embalaje: 10 u/caja.

Aluminium - Packing: 10 u/box.

Precio/Price: € /perfil

Referencia Reference	Colores Colours	a: Ancho Width	h: Altura Height	L: 1 m 3,28 ft	L: 2,5 m 8,2 ft
265A-PB	Plata brillo	85 mm	8 mm	13,05	32,10
265A-PM	Plata mate	85 mm	8 mm	11,29	28,75
265A-BL	Blanco	85 mm	8 mm	11,29	28,75
277A-PB	Plata brillo	85 mm	23 mm	17,12	37,45
277A-PM	Plata mate	85 mm	23 mm	14,98	34,77
277A-BL	Blanco	85 mm	23 mm	14,98	34,77

Acero inoxidable - Embalaje: 10 u/caja.

Stainless steel - Packing: 10 u/box.

265S-IB	Inox brillo	84 mm	10 mm		34,91
---------	-------------	-------	-------	--	-------

*Descatalogado, disponible hasta fin de stock / Out of production, available till end of stock.





Desagüe lineal, el remate perfecto para un plato de ducha elegante.
Lineal drain made of stainless steel, the perfect finish for an elegant shower tray.



INOXIDABLE / STAINLESS STEEL

1701/2/3S

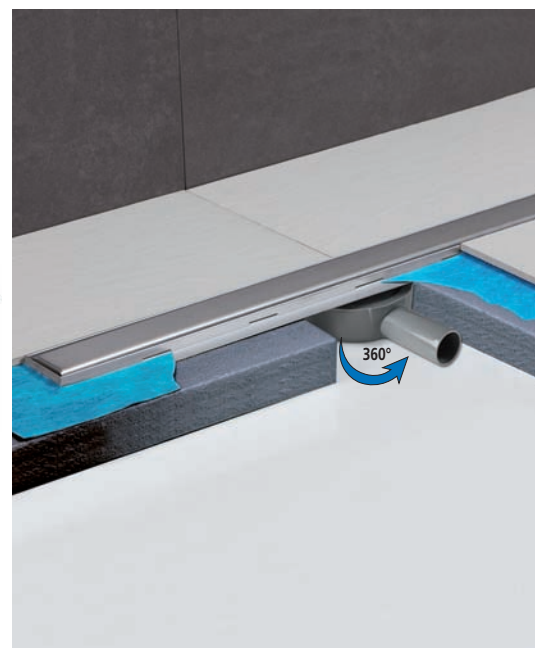
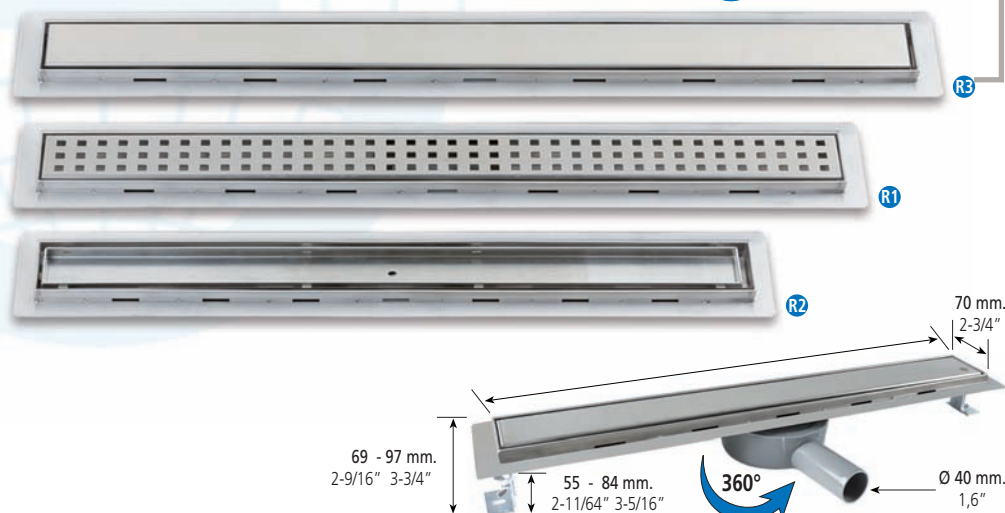

ES EURODESAGÜE-1701/2/3S, Desagüe lineal de salida horizontal en acero inoxidable AISI 304 para platos de ducha de obra, tanto para reformas como para obras nuevas. Ajustable por unas patas laterales a varias alturas, de 6,7 cm a 9,6 cm. El desagüe puede colocarse tanto en el centro del plato de ducha como junto a la pared. Dotado con un sifón extraíble para una limpieza fácil y cómoda. El desagüe posee un marco exterior que permite utilizar cualquier pavimento hasta una altura máxima de 14 mm. Disponible en tres longitudes (60, 70 y 80 cm) con tres acabados distintos: **R1**: Rejilla de cuadrados **R2**: Rejilla para cerámica, con altura máx. de 12 mm **R3**: Rejilla inoxidable cepillado. Caudal evacuación 26 litros/minutos.

EN EURODRAIN-1701/2/3S, Linear drain with horizontal outlet made of AISI 304 stainless steel for floor level shower trays both for remodelling work and new works. Adjustable by means of lateral legs to various heights from 6.7 cm to 9.6 cm. The drain may be placed both in the centre of the shower tray or alongside the wall. Endowed with a removable siphon for easy, convenient cleaning. The drain is endowed with an exterior frame which allows any flooring to be used up to a maximum height of 14 mm. Available in three lengths (60, 70 and 80 cm) with three different finishes: **R1**: Square grating **R2**: Grating for ceramics with a max. height of 12 mm **R3**: Brush-finished stainless steel grating. Evacuation flow 26 liters/minute.



- | | | | |
|--|--|--|---------------------------------------|
| A Rejilla | A Grate | A Grille | A Gitterrost |
| B Cuello lámina impermeabilizante ancho 0,30m | B Waterproof sheet neck width 0,30m | B Col feuille imperméabilisante largeur 0,30m | B Dichtungsfolie weit 0,30m |
| C Sifón extraíble | C Removable water trap. | C Siphon amovible. | C Herausnehmbarer Siphon. |
| D Canal desagüe | D Drainage channel. | D Canal d'évacuation. | D Abwasserrinne. |
| E Patas ajustables 67-96mm | E Adjustable legs, 67-96 mm. | E Pieds ajustables, 67-96 mm. | E Regulierbare Füße, 67-96 mm. |
| F Conexión DN 40 a DN 50 | F DN40 to DN50 connection | F Connexion DN40 à DN50. | F Anschluss DN40 bis DN50. |

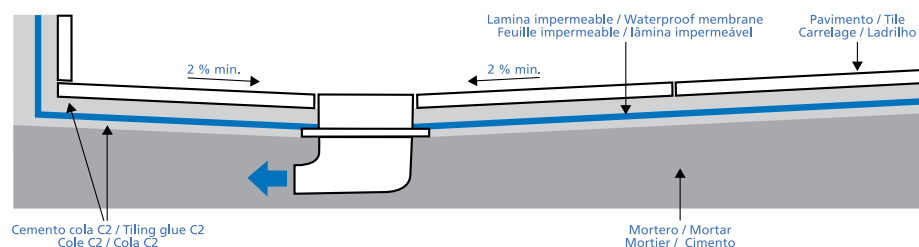

Embalaje: 1u/caja / Packing: 1u/box.

Precio/Price: € /Unidad

Referencia Reference	Colores Colours	L: 60 cm 1,97 ft.	L: 70 cm 2,30 ft.	L: 80 cm 2,62 ft.
1701S-IC/R1	Inox cepillado / R1 (rejilla cuadrados)	135,00	139,00	149,00
1702S-IC/R2	Inox cepillado / R2 (rejilla para cerámica)	135,00	139,00	149,00
1703S-IC/R3	Inox cepillado / R3 (rejilla lisa)	135,00	139,00	149,00

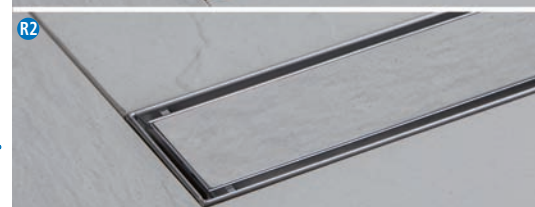
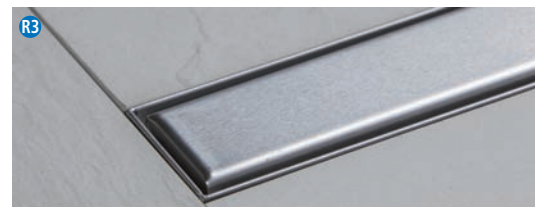

New
colours

ES EURODESAGÜE-1701/3S, Nueva gama de colores para nuestros desagües 1701S y 1703S. Rejilla de acero inoxidable AISI304 en Cobre Brillo, Oro Brillo y Negro Mate a combinar con la base en inoxidable mate de siempre.

EN EURODESAGÜE-1701/3S, A new range of colours for our 1701S and 1703S drains. An AISI304 stainless steel grille in Shiny Copper, Shiny Gold and Matte Black to match the standard stainless steel matte base.

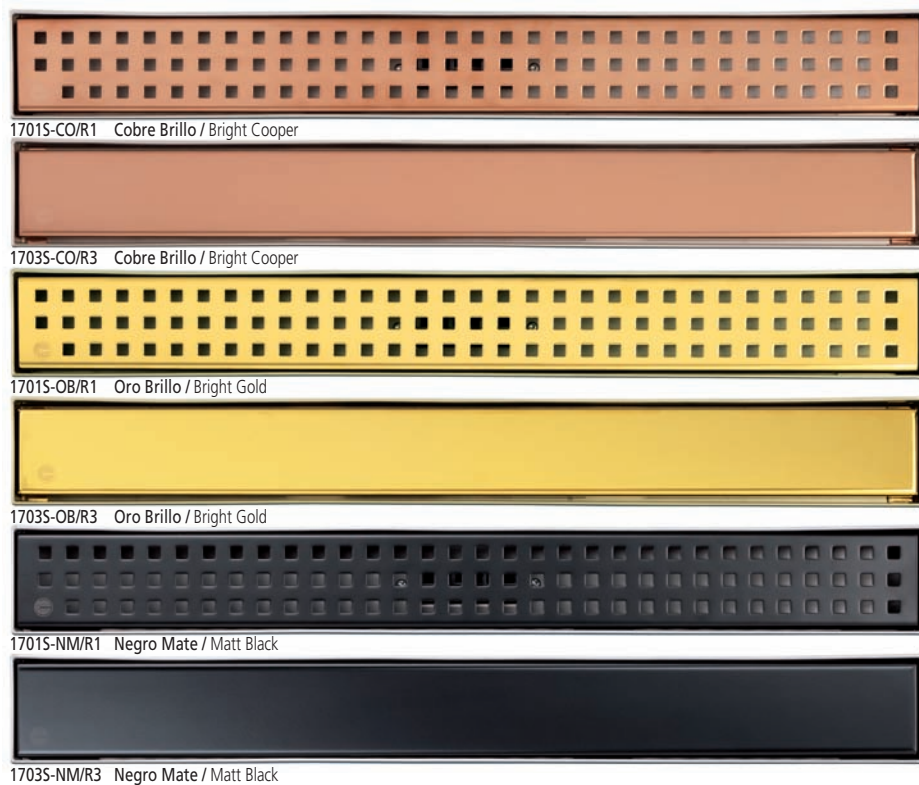

Embalaje: 1 u/caja / Packing: 1 u/box.

Precio/Price: €/Unidad

Referencia Reference	Colores Colours	L: 60 cm 1,97 ft	L: 80 cm 2,62 ft
1701S-CO/R1	Cobre brillo / R1 (rejilla cuadrados)	175,00	195,00
1703S-CO/R3	Cobre brillo / R3 (rejilla lisa)	175,00	195,00
1701S-OB/R1	Oro brillo / R1 (rejilla cuadrados)	175,00	195,00
1703S-OB/R3	Oro brillo / R3 (rejilla lisa)	175,00	195,00
1701S-NM/R1	Negro mate / R1 (rejilla cuadrados)	175,00	195,00
1703S-NM/R3	Negro mate / R3 (rejilla lisa)	175,00	195,00



INOXIDABLE / STAINLESS STEEL

SLIM DRAIN

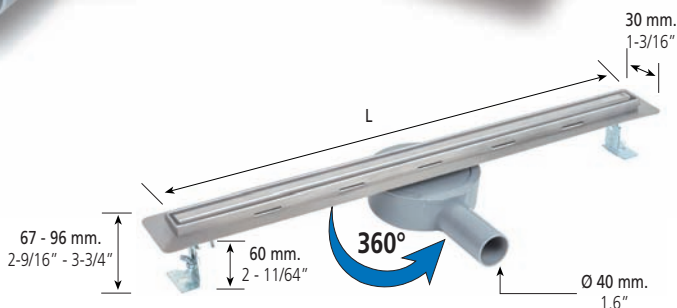

ES EURODESAGÜE-SLIM DRAIN, Desagüe lineal SLIM de acero inoxidable AISI304, con salida horizontal orientable, para platos de ducha de obra. Ajustable por unas patas laterales, de 6,7 a 9,6 cm. Dotado con un sifón extraíble para una limpieza fácil y cómoda. El desagüe posee un marco exterior que permite utilizar cualquier pavimento hasta una altura máxima de 14 mm. Caudal evacuación 26 litros/minutos.

EN EUROWDRAIN-SLIM DRAIN, SLIM linear drainpipe made of AISI304 stainless steel, with adjustable horizontal outlet, for floor-level shower trays. Adjustable by side legs between 6,7 and 9.6cm. Equipped with an extractable trap for an easy and comfortable clean. The drainpipe includes an outer frame that can be used on any tiles up to 14mm in height. Evacuation flow 26 liters/minute.



- | | | | |
|--|--|--|---------------------------------------|
| A Rejilla | A Grate | A Grille | A Gitterrost |
| B Cuello lámina impermeabilizante ancho 0,25m | B Waterproof sheet neck width 0,25m | B Col feuille imperméabilisante largeur 0,25m | B Dichtungsfolie weit 0,25m |
| C Sifón extraíble | C Removable water trap. | C Siphon amovible. | C Herausnehmbarer Siphon. |
| D Canal desagüe | D Drainage channel. | D Canal d'évacuation. | D Abwassertrenne. |
| E Patas ajustables 67-96mm | E Adjustable legs, 67-96 mm. | E Pieds ajustables, 67-96 mm. | E Regulierbare Füße, 67-96 mm. |
| F Conexión DN 40 a DN 50 | F DN40 to DN50 connection | F Connexion DN40 à DN50. | F Anschluss DN40 bis DN50. |

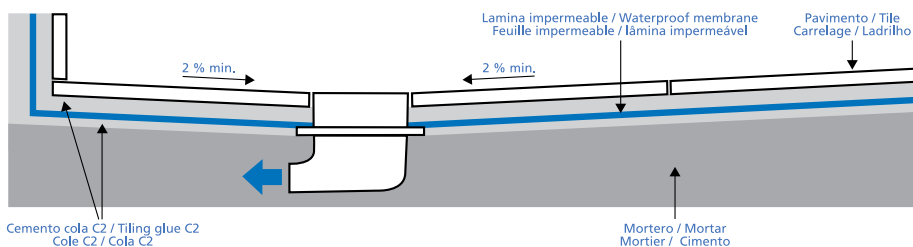

Embalaje: 1u/caja / Packing: 1u/box.

Precio/Price: € /Unidad

Referencia Reference	Colores Colours	L: 60 cm 1,97 ft.	L: 80 cm 2,62 ft.
SLIM DRAIN / 60	Inox cepillado	99,00	
SLIM DRAIN / 80	Inox cepillado		115,00

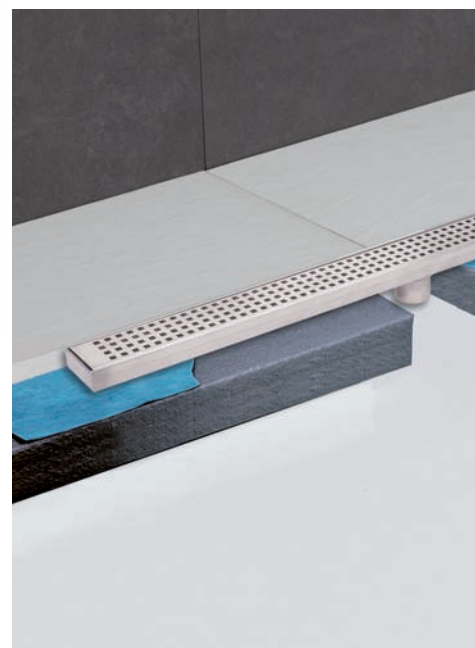
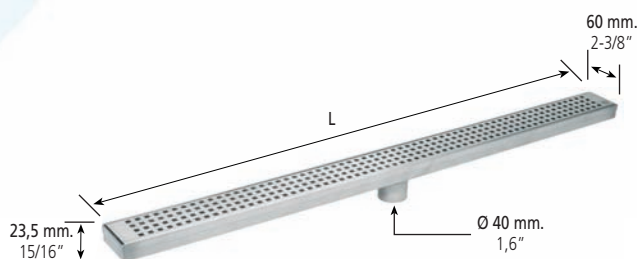

ES EURODESAGÜE-1601S, Desagüe lineal con salida vertical de acero inoxidable AISI304 para platos de ducha de obra.
Caudal evacuación 25 litros/minutos.

EN EURORAIN-1601S, lineal drainpipe with vertical outlet made of AISI304 stainless steel for floor-level shower trays
Evacuation flow 25 liters/minute

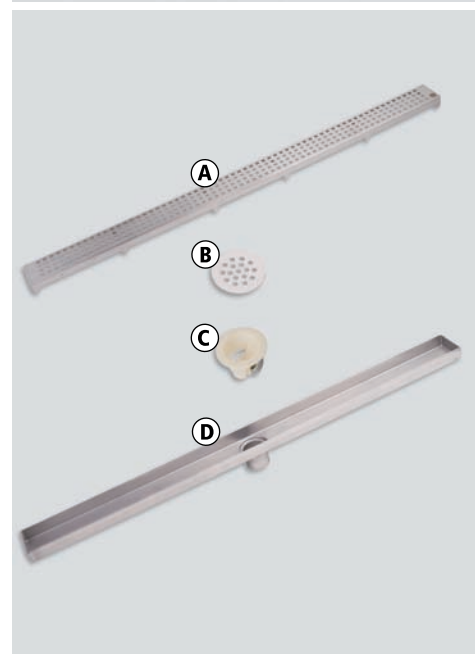

- | | | | |
|-----------------------------|-----------------------------|------------------------------|------------------------------------|
| A Rejilla | A Grate | A Grille | A Gitterrost |
| B Rejilla sifón | B Siphon grid | B Grille de siphon | B Siphon-Gitter |
| C Sifón extraíble magnético | C Removable magnetic siphon | C Siphon magnétique amovible | C Abnehmbarer magnetischer Siphon. |
| D Canal desagüe | D Drainage channel | D Canal d'évacuation. | D Abwasserrinne. |

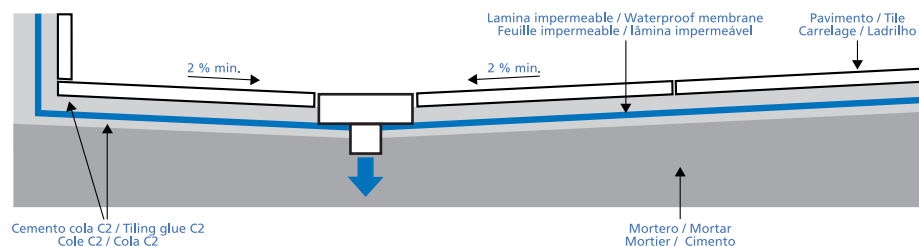

Embalaje: 1u/caja / Packing: 1u/box.

Precio/Price: € /Unidad

Referencia Reference	Colores Colours	L: 60 cm 1,97 ft.	L: 80 cm 2,62 ft.	L: 100 cm 3,28 ft.
1601	Inox cepillado / R1 (rejilla cuadrados)	82,00	98,00	115,00



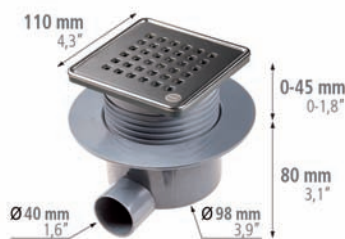

ES EURODESAGUE PREMIUM, Kit de impermeabilización para duchas de obra, tanto para reformas como para obras nuevas, con rejilla de acero inoxidable AISI 304. Desagüe de salida horizontal y vertical de 40 mm y evacuación de 44,6 l/mn que cumple con la normativa EN274 y EN1329-1. Dotado con un sifón extraíble para una limpieza fácil y cómoda. El Kit incorpora la lámina impermeable WATERPROOF.5, para proporcionar una estanqueidad total del plato de ducha y para que en caso de filtraciones a través de las juntas del pavimento el agua siempre acabe en el desagüe.

EN EURORAIN PREMIUM, Waterproofing kit for built-in showers, both for remodelling and new works, with a stainless steel grating AISI 304. 40 mm horizontal and vertical outlet drain and runoff of 44.6 l/mn which complies with the standard EN274 and EN1329-1. Fitted with an extractable siphon for easy, convenient cleaning. The Kit incorporates the waterproof sheet WATERPROOF.5 to provide total watertightness of the shower tray and so that in the event of leakage through the flooring joints the water always ends up in the drain.

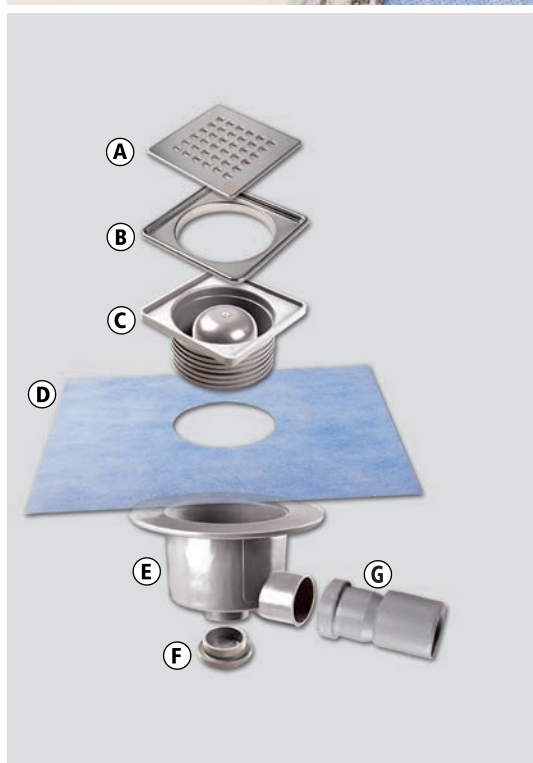

- A) Rejilla (acero inoxidable brillo AISI304).
- B) Marco (acero inoxidable brillo AISI304).
- C) Sifón regulable en altura con junta de goma estanca.
- D) Cuello de lámina impermeable sellado de 0,4 x 0,4 m. y lámina impermeable de 1,5 x 2 m.
- E) Base desagüe con salida horizontal / vertical de Ø 40.
- F) Tapón Ø 40.
- G) Conexión DN40 a DN50.

- A) Grating (shiny stainless steel AISI304).
- B) Frame (shiny stainless steel AISI304).
- C) Height-adjustable siphon with watertight rubber joint.
- D) Sealed waterproof sheet neck 0.4 x 0.4 m. and waterproof sheet 1.5 x 2 m.
- E) Drain base with horizontal / vertical outlet Ø 40.
- F) Plug Ø 40.
- G) Connection DN40 to DN50..

- A) Grille (acier inoxydable brillant AISI304)
- B) Cadre (acier inoxydable brillant AISI304)
- C) Siphon réglable en hauteur avec joint en caoutchouc étanche.
- D) Col en feuille imperméable de 0,4 x 0,4 m. et feuille imperméable de 1,5 x 2 m.
- E) Base d'écoulement avec sortie horizontale / verticale de DN 40.
- F) Bouchon Ø 40.
- G) Connexion DN40 à DN50.

- A) Gitter (glänzender rostfreier Stahl des Typs AISI304)
- B) Rahmen (glänzender rostfreier Stahl des Typs AISI304)
- C) In der Höhe einstellbarer Siphon mit Gummidichtung
- D) Versiegelter Hals aus wasserdichter Folie von 0,4 x 0,4 m und wasserdichte Folie von 1,5 x 2 m.
- E) Abfluss-Sockel mit horizontalem / vertikalem Ausgang DN 40
- F) Verschlussstopfen Ø 40.
- G) Anschlüsse DN40 bis DN50

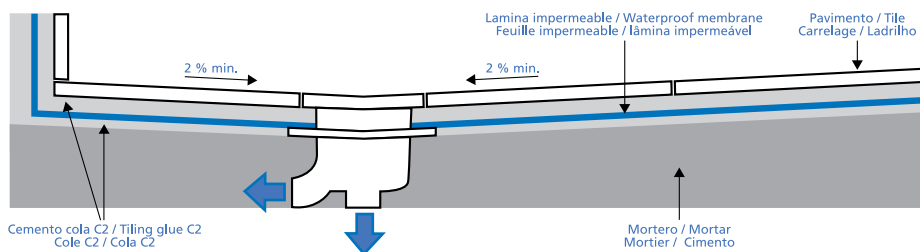

Referencia Reference	Colores Colours	Ancho (a) Width (a)	€ / u.	U. / Caja U. / Box
Kit PREMIUM IB/R1	Inox Brillo / R1 Bright Inox / R1	110 x 110 mm. 4,3" x 4,3"	71,56	1
Kit PREMIUM IC/R1	Inox Cepillado / R1 Brushed Inox / R1	110 x 110 mm. 4,3" x 4,3"	71,56	1



New
colours

INOXIDABLE / STAINLESS STEEL

Kit PREMIUM



ES EURODESAGÜE PREMIUM, Nueva gama de colores para nuestro desagüe Kit PREMIUM, de acero inoxidable AISI304 en Cobre Brillo, Oro Brillo y Negro Mate.

EN EURODRAIN PREMIUM, A new range of colours for our Kit PREMIUM, AISI304 stainless steel in Bright Copper, Bright Gold and Matt Black.

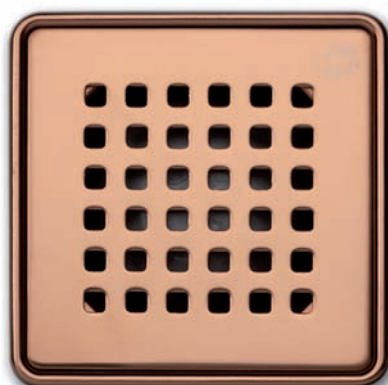

PREMIUM Cobre Brillo / Bright Cooper



PREMIUM Oro Brillo / Bright Gold



PREMIUM Negro Mate / Matt Black

Referencia Reference	Colores Colours	Ancho (a) Width (a)	€ / u.	U. / Caja U. / Box
Kit PREMIUM CO/R1	Cobre Brillo / R1 Bright Cooper / R1	110 x 110 mm. 4,3" x 4,3"	114,44	1
Kit PREMIUM OB/R1	Oro Brillo / R1 Bright Gold / R1	110 x 110 mm. 4,3" x 4,3"	114,44	1
Kit PREMIUM NM/R1	Negro Mate / R1 Matt Black / R1	110 x 110 mm. 4,3" x 4,3"	114,44	1



INOXIDABLE / STAINLESS STEEL

Kit CLASSIC

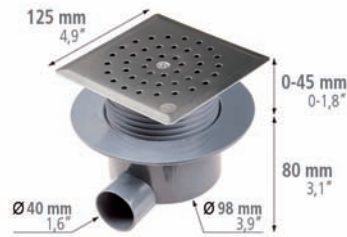
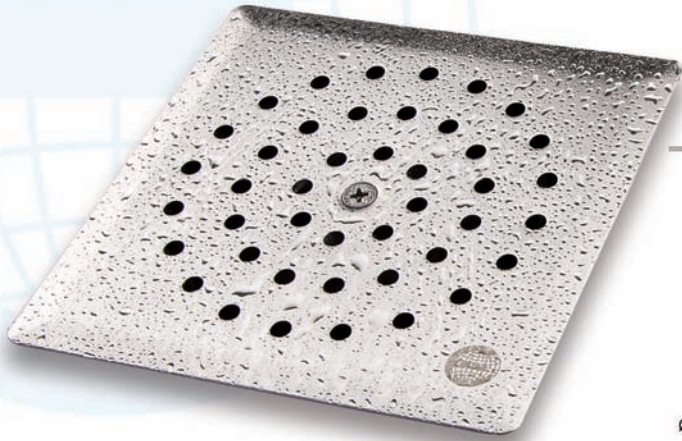

ES EURODESAGÜE CLASSIC, Kit de impermeabilización para duchas de obra, tanto para reformas como para obras nuevas, con rejilla de acero inoxidable AISI 304. Desagüe de salida horizontal y vertical de 40 mm y evacuación de 44,6 l/mn que cumple con la normativa EN274 y EN1329-1. Dotado con un sifón extraíble para una limpieza fácil y cómoda. El Kit incorpora la lámina impermeable WATERPROOF.5, para proporcionar una estanqueidad total del plato de ducha y para que en caso de filtraciones a través de las juntas del pavimento el agua siempre acabe en el desagüe.

EN EURORAIN CLASSIC, Waterproofing kit for built-in showers, both for remodelling and new works, with a stainless steel grating AISI 304. 40 mm horizontal and vertical outlet drain and runoff of 44.6 l/mn which complies with the standard EN274 and EN1329-1. Fitted with an extractable siphon for easy, convenient cleaning. The Kit incorporates the waterproof sheet WATERPROOF.5 to provide total watertightness of the shower tray and so that in the event of leakage through the flooring joints the water always ends up in the drain.

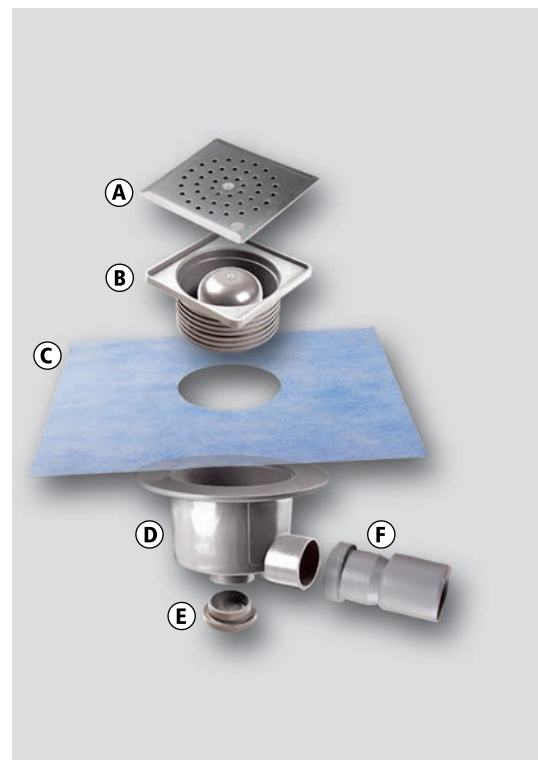

- A) Rejilla (acero inoxidable cepillado AISI304).
- B) Sifón regulable en altura con junta de goma estanca.
- C) Cuello de lámina impermeable sellado de 0,4 x 0,4 m. y lámina impermeable de 1,5 x 2 m.
- D) Base desagüe con salida horizontal / vertical de Ø 40.
- E) Tapón Ø 40.
- F) Conexión DN40 a DN50.

- A) Grating (brushed stainless steel AISI304).
- B) Height-adjustable siphon with watertight rubber joint.
- C) Sealed waterproof sheet neck 0.4 x 0.4 m. and waterproof sheet 1.5 x 2 m.
- D) Drain base with horizontal / vertical outlet Ø 40.
- E) Plug Ø 40.
- F) Connection DN40 to DN50.

- A) Grille (acier inoxydable brillant AISI304)
- B) Siphon réglable en hauteur avec joint en caoutchouc étanche.
- C) Col en feuille imperméable de 0,4 x 0,4 m. et feuille imperméable de 1,5 x 2 m.
- D) Base d'écoulement avec sortie horizontale / verticale de DN 40.
- E) Bouchon Ø 40.
- F) Connexion DN40 à DN50.

- A) Gitter (glänzender rostfreier Stahl des Typs AISI304)
- B) In der Höhe einstellbarer Siphon mit Gummidichtung
- C) Versiegelter Hals aus wasserdichter Folie von 0,4 x 0,4 m und wasserdichte Folie von 1,5 x 2 m.
- D) Abfluss-Sockel mit horizontalem /vertikalem Ausgang DN 40
- E) Verschlussstopfen Ø 40.
- F) Anschlüsse DN40 bis DN50

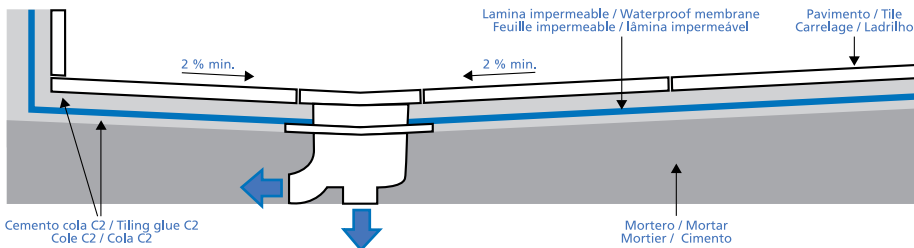

Referencia Reference	Colores Colours	Ancho (a) Width (a)	€/ u.	U. / Caja U. / Box
Kit CLASSIC IC/R4	Inox Cepillado / R4 Brushed Inox / R4	125 x 125 mm. 4,9" x 4,9"	58,50	1



INOXIDABLE / STAINLESS STEEL Kit CERAMIC

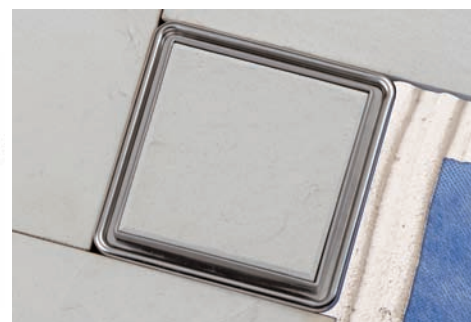
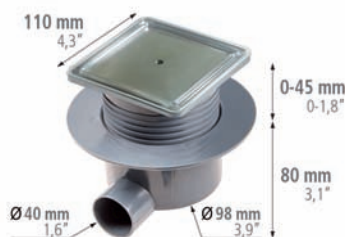
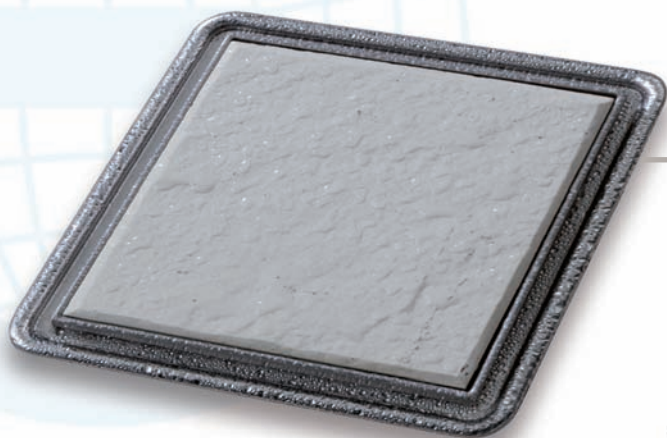

ES EURODESAGÜE CERAMIC, Kit de impermeabilización para duchas de obra, tanto para reformas como para obras nuevas, con rejilla de acero inoxidable AISI 304. Desagüe de salida horizontal y vertical de 40 mm y evacuación de 44,6 l/mn que cumple con la normativa EN274 y EN1329-1. Dotado con un sifón extraíble para una limpieza fácil y cómoda. El Kit incorpora la lámina impermeable WATERPROOF.5, para proporcionar una estanqueidad total del plato de ducha y para que en caso de filtraciones a través de las juntas del pavimento el agua siempre acabe en el desagüe.

EN EURORAIN CERAMIC, Waterproofing kit for built-in showers, both for remodelling and new works, with a stainless steel grating AISI 304. 40 mm horizontal and vertical outlet drain and runoff of 44.6 l/mn which complies with the standard EN274 and EN1329-1. Fitted with an extractable siphon for easy, convenient cleaning. The Kit incorporates the waterproof sheet WATERPROOF.5 to provide total watertightness of the shower tray and so that in the event of leakage through the flooring joints the water always ends up in the drain.

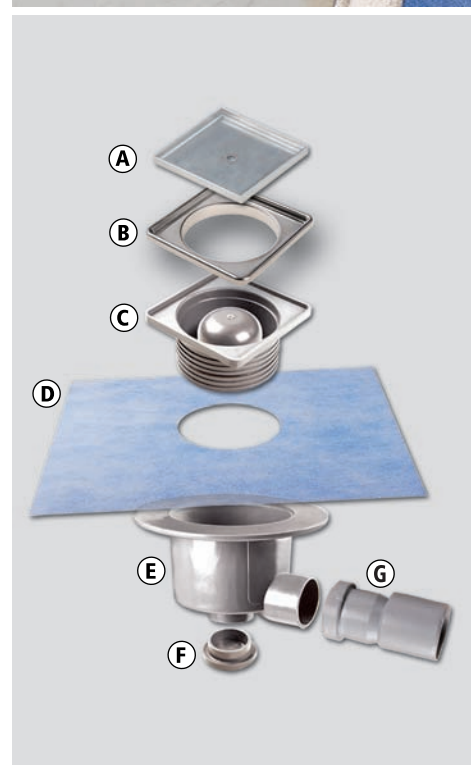

- A) Rejilla para cerámica Max. 12mm (acero inox. brillo AISI304).
- B) Marco (acero inoxidable brillo AISI304).
- C) Sifón regulable en altura con junta de goma estanca.
- D) Cuello de lámina impermeable sellado de 0,4 x 0,4 m. y lámina impermeable de 1,5 x 2 m.
- E) Base desagüe con salida horizontal / vertical de Ø 40.
- F) Tapón Ø 40.
- G) Conexión DN40 a DN50.

- A) Grating for pavement max. 12mm (shiny AISI304).
- B) Frame (shiny stainless steel AISI304).
- C) Height-adjustable siphon with watertight rubber joint.
- D) Sealed waterproof sheet neck 0.4 x 0.4 m. and waterproof sheet 1.5 x 2 m.
- E) Drain base with horizontal / vertical outlet Ø 40.
- F) Plug Ø 40.
- G) Connection DN40 to DN50.

- A) Grille pour revêtement max. 12mm (brillant AISI304)
- B) Cadre (acier inoxydable brillant AISI304)
- C) Siphon réglable en hauteur avec joint en caoutchouc étanche.
- D) Col en feuille imperméable de 0,4 x 0,4 m. et feuille imperméable de 1,5 x 2 m.
- E) Base d'écoulement avec sortie horizontale / verticale de DN 40.
- F) Bouchon Ø 40.
- G) Connexion DN40 à DN50

- A) Gitter für Boden mit fliesen max. 12mm (AIS1304)
- B) Rahmen (glänzender rostfreier Stahl des Typs AISI304)
- C) In der Höhe einstellbarer Siphon mit Gummidichtung
- D) Versiegelter Hals aus wasserdichter Folie von 0,4 x 0,4 m und wasserdichte Folie von 1,5 x 2 m.
- E) Abfluss-Sockel mit horizontalem / vertikalem Ausgang DN 40
- F) Verschlussstopfen Ø 40.
- G) Anschlüsse DN40 bis DN50

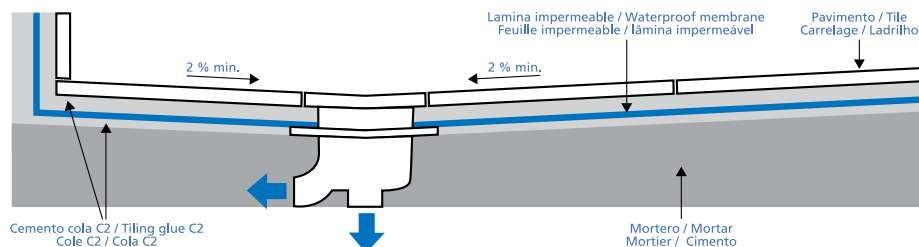

Referencia Reference	Colores Colours	Ancho (a) Width (a)	€ / u.	U. / Caja U. / Box
Kit CERAMIC IB/R2	Inox Brillo / R2 Bright Inox / R2	110 x 110 mm. 4,3" x 4,3"	75,63	1

Eurodesagüe,
la solución elegante para su ducha
Eurodrain,
smart solution for your shower

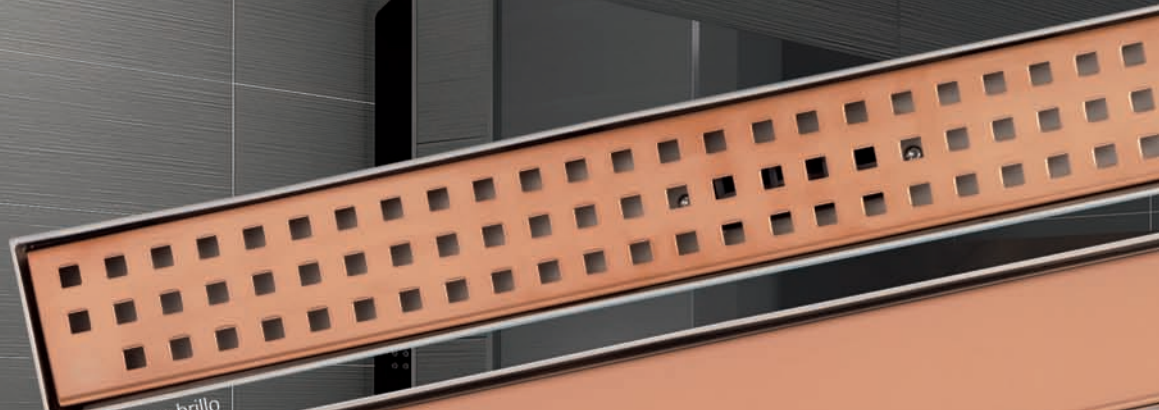

1701S Cobre brillo



1703S Cobre brillo

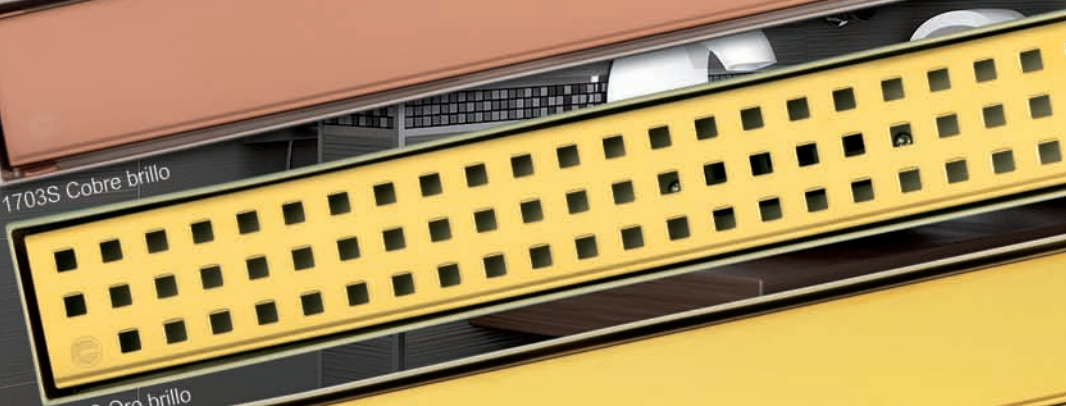

1701S Oro brillo



1703S Oro brillo



1701S Negro mate



1703S Negro mate

New colours

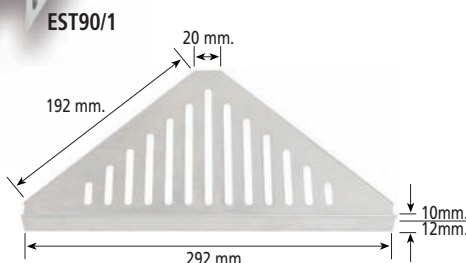
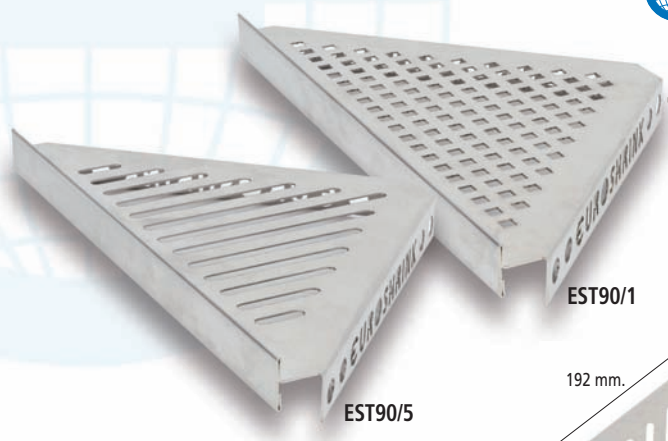

ES EUROESTANTE-EST90, Estante esquinero de acero inoxidable AISI304 para revestimiento cerámico. Estante de cantos redondeados con decoración drenante en la superficie horizontal, que se coloca durante la obra de dos maneras posible:

- El estante con acabado acero inoxidable.
- Colocando sobre el estante la cerámica, de 3 a 12 mm.

EN EUROSHELVES-EST90, AISI304 Stainless-steel corner shelves for a ceramic finishing. Shelves made up of rounded edges with a drainage design over the horizontal surface, which can be put in during the work in two possible ways:

- The shelves with a stainless-steel finish.
- Placing ceramic (3-12mm) over the shelves.

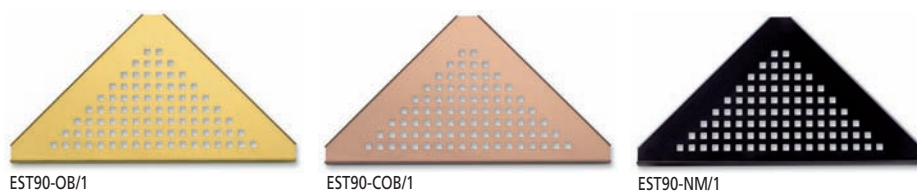

*Nuevos colores combinables con la nueva gama de color de Eurodesagües y de la referencia 212S inoxidable.
*New colours that can be matched with the new Eurodrain colour range and the reference 212S stainless.

Referencia Reference	Colores Colours	Ancho (a) Width (a)	€ / u.	U. / Caja U. / Box
EST90/1	Inox Cepillado / Brushed Inox	292 x 192 mm.	35,00	1
NEW EST90-OB/1	Oro Brillo / Bright Gold	292 x 192 mm.	45,00	1
NEW EST90-COB/1	Cobre Brillo / Bright Cooper	292 x 192 mm.	45,00	1
NEW EST90-NM/1	Negro Mate / Matt Black	292 x 192 mm.	45,00	1
EST90/5	Inox Cepillado / Brushed Inox	292 x 192 mm.	35,00	1



WATERPROOF .5

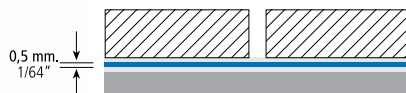
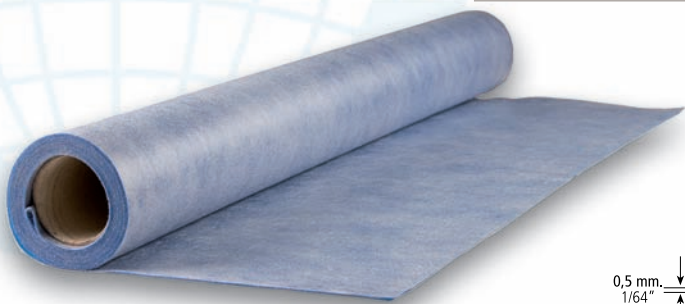

ES EUROLAMINA IMPERMEABLE. Lámina impermeable flexible de polietileno recubierta por una tela no tejida de fibras sintéticas, que garantiza el agarre total de la lámina en su colocación con cemento cola C2. Recomendada su colocación, junto con revestimiento o pavimento, para la impermeabilización de balcones y zonas húmedas interiores.

* Encolado entre lámina y mortero con cemento cola tipo C2. La base de mortero tiene que estar completamente limpia y seca antes del pegado.

* Encolado entre láminas, solapado entre ambas mínimo 10cm, con adhesivo impermeable bicomponente elástico o masilla adhesiva selladora.

⚠ Los rollos se deben almacenar en su embalaje original, en posición horizontal y en un lugar fresco y seco. Se deben proteger de la luz directa del sol, la lluvia, la nieve y las heladas, etc.

EN EUROWATERPROOF SHEET, Flexible polyethylene waterproof sheet coated by on-woven fabric with synthetic fibres which ensures the total adherence of the sheet in its place with cement glue C2. Recommended to waterproof balconies or damp interior, together with coating or flooring.

* Stuck between the sheet and the mortar using C2 cement glue. The mortar base must be totally clean and dry before sticking.

* Stuck between sheets ,minimum overlap between two 10cm, with two-component elastic waterproof adhesive or adhesive sealant putty.

⚠ The rolls should be stored in its original packaging, horizontal and a cool, dry place. They should be protected from direct sunlight, rain, snow and frost, etc.

Características técnicas / Technical characteristics:

Estanqueidad al agua/Watertightness/Étanche/A prova d'água.....	UNE-EN 1928 B
Propiedades de transmisión de vapor de agua/water vapour transmission properties/ Les propietés de transmission de vapeur d'eau/Propriedades de transmissão de vapor de água.....	UNE-EN 1931
Plegabilidad a baja Temperatura/Foldability at low temperatures/ Souplesse à basse température/Flexibilidade a baixa temperatura.....	UNE-EN 495-5
Resistencia al desgarro/Resistance of tearing/Résistance à la déchirure/Resistência ao rasgo.....	UNE-EN 12301-2
Resistencia a la tracción/Tensile strenght/Résistance à la traction/Resistência à tracção.....	UNE-EN 12311-2

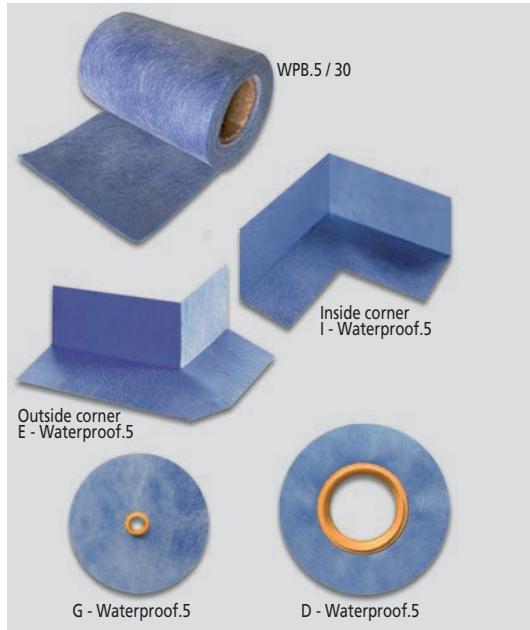
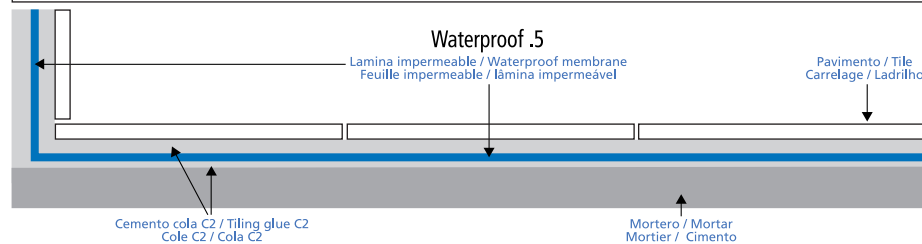

Referencia Reference	Colores Colours	Ancho (a) Width (a)	Longitud Length	€/ u.	U. / Caja U. / Box
Waterproof .5 / 5	Azul Blue	1 m. 3,28 ft.	5 m. 16,4 ft.	64,20	8
Waterproof .5 / 30	Azul Blue	1 m. 3,28 ft.	30 m. 98,4 ft.	288,90	2
New Waterproof .5 / 30 / 2	Azul Blue	1,95 m. 6,56 ft.	30 m. 98,4 ft.	525,50	1
New WPB.5 / 30	Azul Blue	12 cm.	30 m. 98,4 ft.	48,31	1
New E - Waterproof .5	Azul Blue	14 x 6 cm.		11,82	2
New I - Waterproof .5	Azul Blue	14 x 6 cm.		11,82	2
New G - Waterproof .5	Azul Blue	ø 23 mm. (Interior)	ø 200 mm. (Exterior)	13,51	1
New D - Waterproof .5	Azul Blue	ø 115 mm. (Interior)	ø 216 mm. (Exterior)	20,61	1

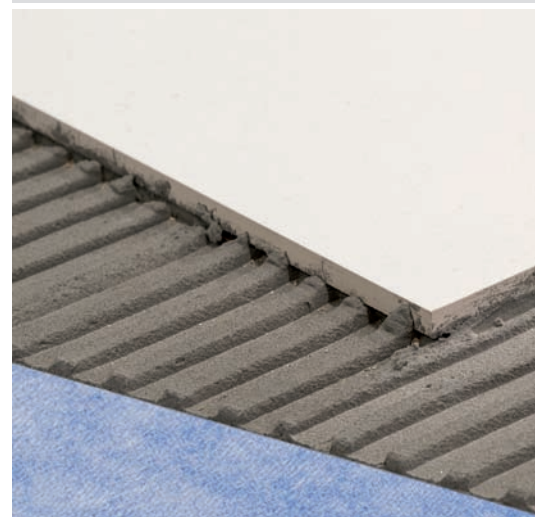

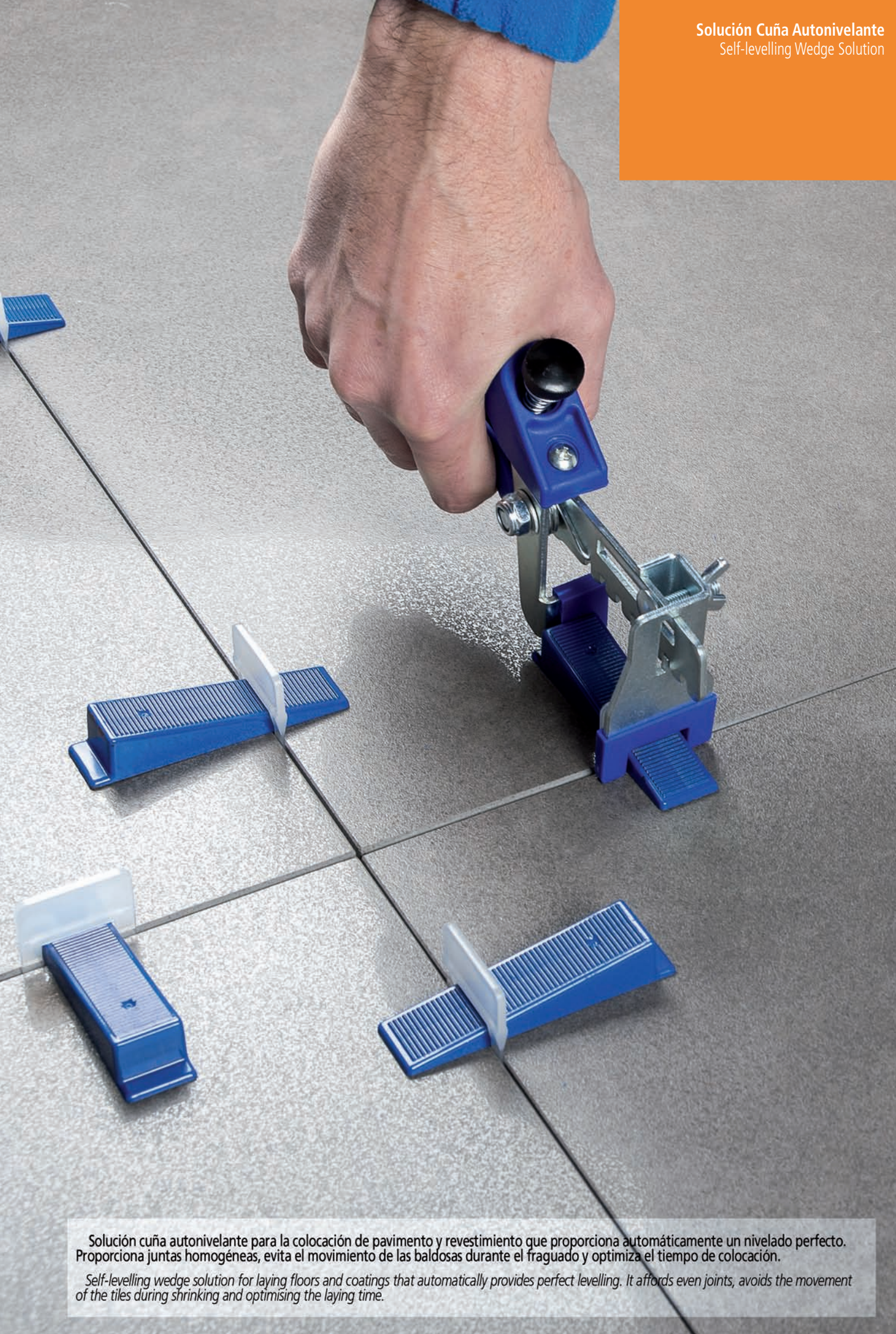

Solución cuña autonivelante para la colocación de pavimento y revestimiento que proporciona automáticamente un nivelado perfecto. Proporciona juntas homogéneas, evita el movimiento de las baldosas durante el fraguado y optimiza el tiempo de colocación.

Self-levelling wedge solution for laying floors and coatings that automatically provides perfect levelling. It affords even joints, avoids the movement of the tiles during shrinking and optimising the laying time.

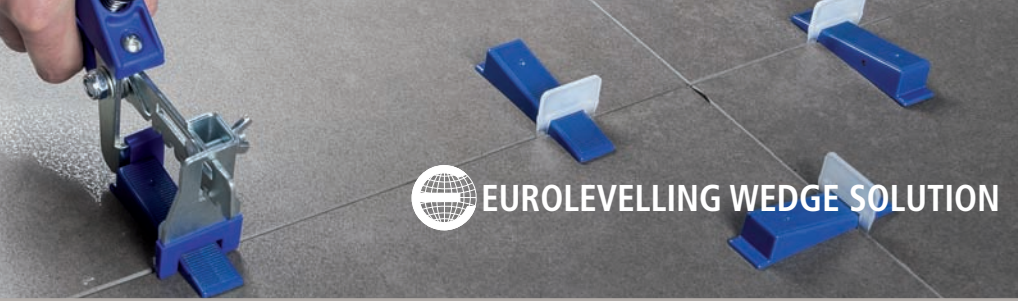

Solución Cuña Autonivelante
Self-levelling Wedge Solution

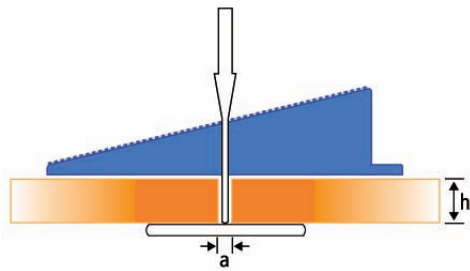

ES EUROCUÑA AUTONIVELANTE, Solución cuña autonivelante para la colocación de pavimento y revestimiento que proporciona automáticamente un nivelado perfecto. Proporciona juntas homogéneas, evita el movimiento de las baldosas durante el fraguado y optimiza el tiempo de colocación.

PROTECT/WEDGE: protector de cerámica para nuestro sistema autonivelante WEDGE.

E90/WEDGE: Complemento esquinas 90° para sistema autonivelante WEDGE.

PLATFORM/WEDGE: Suplemento para cerámica SLIM de 2-5mm. Sistema autonivelante WEDGE.

RODILLO/WEDGE: rodillo ajustable según su altura, para facilitar y agilizar la retirada de nuestro sistema autonivelante WEDGE.

EN EUROLEVELLING WEDGE, Self-levelling wedge solution for laying floors and coatings that automatically provides perfect levelling. It affords even joints, avoids the movement of the tiles during shrinking and optimising the laying time.

PROTECT/WEDGE: ceramic protector for our self-levelling WEDGE system.

E90/WEDGE: 90° corner complement for WEDGE self-leveling system.

PLATFORM/WEDGE: Supplement for 2-5mm SLIM ceramics. WEDGE self-leveling system.

ROLLER/WEDGE: roller that can be adjusted based on its height in order to facilitate and speed up the withdrawal of our self-levelling WEDGE system.



Reutilizable / Reusable



Eurocuña / Wedge



Eurobrida

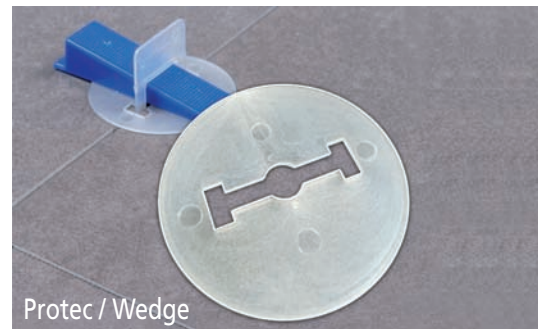

Protec / Wedge

Modo de uso / How to use

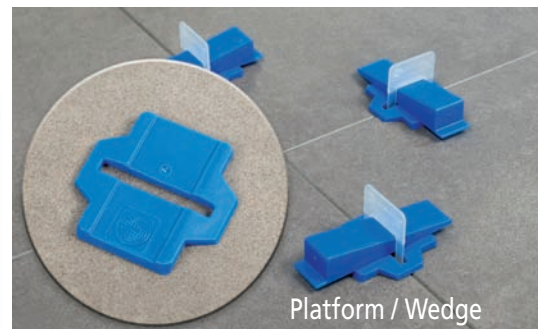
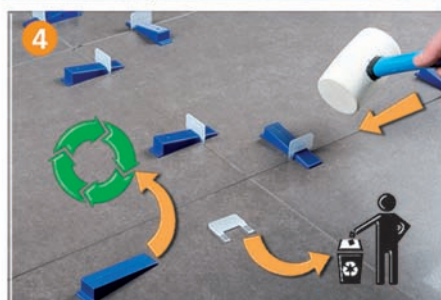
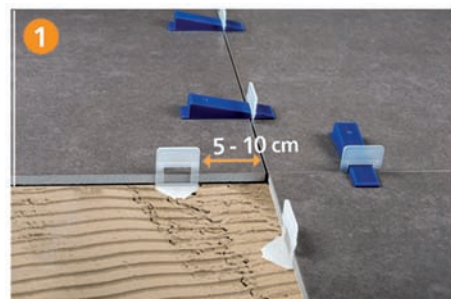

Platform / Wedge



E90 / Wedge

EUROLEVELLING WEDGE SOLUTION

Referencia Reference	Unidades / Bolsa Units Bag	Ancho (a) Width (a)	Altura (h) Height (h)	€ / u.	Bolsas / Caja Bags / Box
Cuña	300			36,03	10
Brida 0.5 / 300	300	0,5 mm	2 - 15 mm	26,57	10
Brida 1	300	1 mm	2 - 15 mm	26,57	10
Brida 1.5 / 300	300	1,5 mm	2 - 12 mm	26,57	10
Brida 2	300	2 mm	2 - 12 mm	26,57	10
Brida 2 XL / 100	100	2 mm	12 - 20 mm	12,40	40
Brida 3 / 100	100	3 mm	2 - 12 mm	11,30	40
Protect / Wedge	100			18,59	12
E90 / Wedge	25		2,5 mm	13,09	40
Platform / Wedge	100		4 mm	19,21	40
Tenaza	1			25,16	24
Tenaza / Pared	1			28,85	24
Wedge Kit 1mm	100 Bidas 1mm + 100 Cuñas + 1Tenaza	1 mm	2 - 15 mm	49,85	8
Wedge Kit 0,5mm	100 Bidas 0,5mm + 100 Cuñas + 1Tenaza	0,5 mm	2 - 15 mm	49,85	8
Wedge Kit 2 mm	100 Bidas 2 mm + 100 Cuñas + 1Tenaza	2 mm	2 - 12 mm	50,85	8
Rodillo / Wedge	1			79,90	1

*Platform / Wedge: Para azulejos SLIM de 2 a 5 mm / For SLIM tiles 2 - 5 mm

Piezas x m² / Pieces x m²

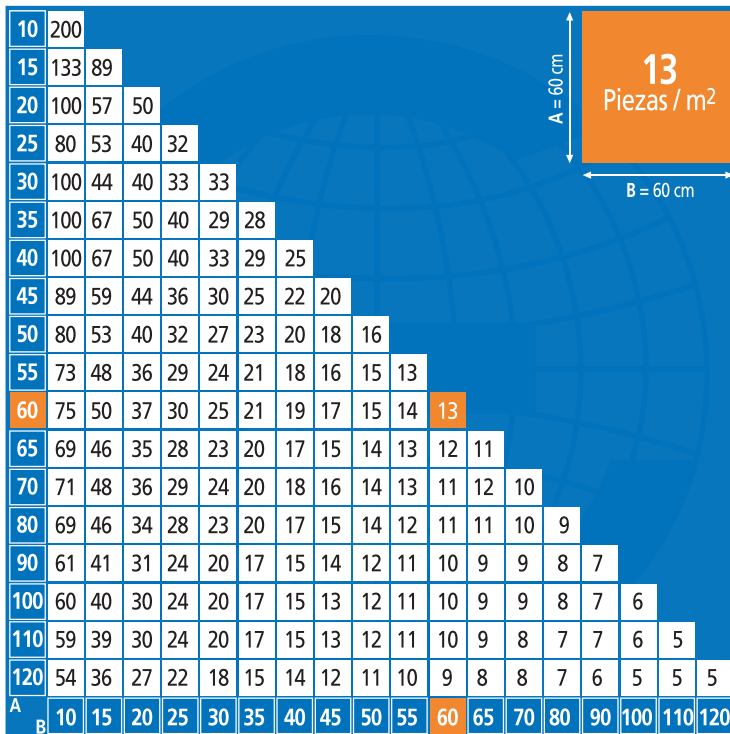

Modo de uso / How to use

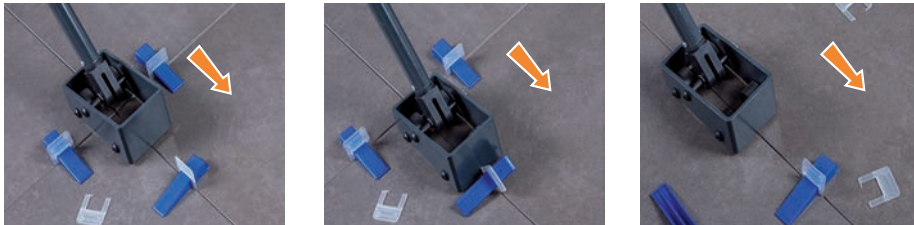

Autonivelante
Self-levelling

Rodillo / Wedge



EUROLEVELLING SOLUTION

Level Kit

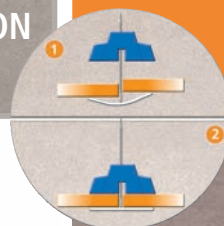
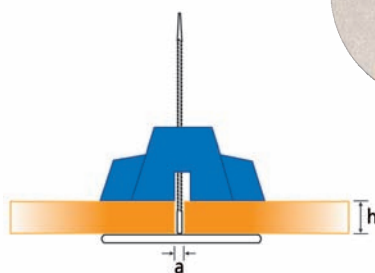

Eurobase / Base



Eurocapucha / Cap



Eurocapucha XL / Cap XL



Europistola / Gun

ES EUROSOLUCION AUTONIVELANTE, Solución autonivelante para la colocación de pavimento y revestimiento que proporciona automáticamente un nivelado perfecto. Proporciona juntas homogéneas, evita el movimiento de las baldosas durante el fraguado y optimiza el tiempo de colocación. Gracias al capuchón de larga durabilidad que proporciona la placa metálica que hemos incorporado, se reducen considerablemente los costes de colocación pues este puede ser reutilizado más de 50 veces. Eurocapucha XL para grandes formatos.

EN EUROLEVELLING SYSTEM, Self-levelling solution for laying floors and coatings that automatically provides perfect levelling. It affords even joints, avoids the movement of the tiles during shrinking and optimising the laying time. Thanks to the long-life cap afforded by the metallic plate we have incorporated, there is a considerable reduction in laying costs as the latter may be reused more than 50 times. Eurocap XL for large formats.

Referencia Reference	Unidades / Bolsa Units Bag	Ancho (a) Width (a)	Altura (h) Height (h)	€/ u.	Bolsas / Caja Bags / Box
Level Kit	100 Base + 100 Capucha + 1 Pistola	1,5 mm	3 - 40 mm	53,50	6
Level Base	100	1,5 mm	3 - 40 mm	11,29	10
Level Base 0,75	100	0,75 mm	3 - 17 mm	11,29	10
Level Cap	100			15,52	10
Level Cap XL	100			31,99	12
Level Gun	1			26,75	5

CM	10	20	30	40	50	60	70	80	90	100	110	120
10	44 Pcs/M ²											
20	25 Pcs/M ²											
30	11 Pcs/M ²											
40	7 Pcs/M ²											
50	6 Pcs/M ²											
60	6 Pcs/M ²											
70	6 Pcs/M ²											
80	6 Pcs/M ²											
90	6 Pcs/M ²											
100	6 Pcs/M ²											
110	6 Pcs/M ²											
120	6 Pcs/M ²											

CM	10	20	30	40	50	60	70	80	90	100	110	120
10	50 Pcs/M ²											
20	22 Pcs/M ²											
30	9 Pcs/M ²											
40	6 Pcs/M ²											
50	6 Pcs/M ²											
60	6 Pcs/M ²											
70	6 Pcs/M ²											
80	6 Pcs/M ²											
90	6 Pcs/M ²											
100	6 Pcs/M ²											
110	6 Pcs/M ²											
120	6 Pcs/M ²											

A = 60 cm
B = 60 cm
11 Piezas / m² } Ejemplo / Example

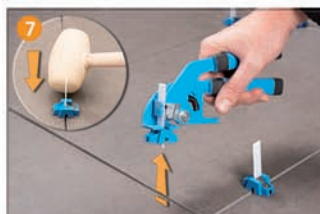
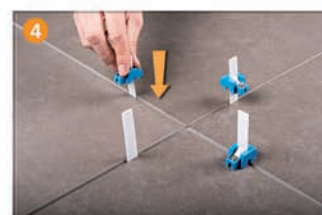
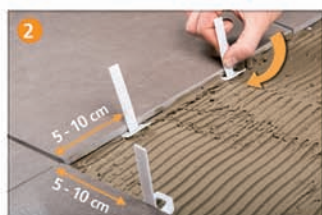



CRUCETA



T



CUÑA



CPLUS



CPLUS (Reutilizable / Reusable)

ES EUROCRUCETAS, piezas inyectadas para la colocación del azulejo, el gres, etc. Al utilizar nuestras crucetas conseguirá una línea perfecta y siempre idéntica entre la cerámica que utilice.

La gran variedad de medidas en que se presentan permiten su utilización con cualquier material. Disponibles en diferentes formas: cruceta (C), cruceta reutilizable (C+), cuña (CU), pieza en T (T).

EUROCRUCETAS 202, cruceta para una rápida y fácil colocación de los bloques de vidrio.

EN EUROCROSSPIECES, injected pieces for installing tiles, sandstone, etc.

With the EUROCROSSPIECES you always achieve perfect and identical lines between ceramic tiles used. The great variety of sizes presented allow their use with any material. The EUROCROSSPIECES are available in different forms: crosspiece (C), crosspiece reusable (C+), wedge (CU), and T form (T).

EUROCROSSPIECES 202, crosspieces for simple and fast fitting of glass blocks.

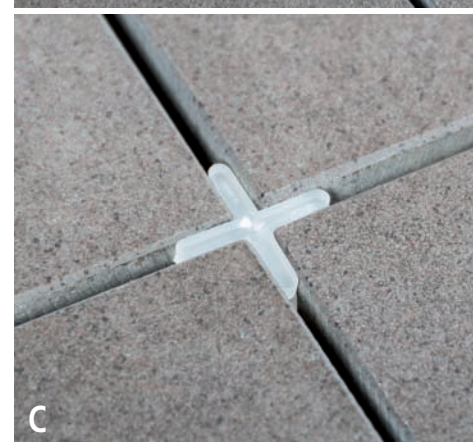

C

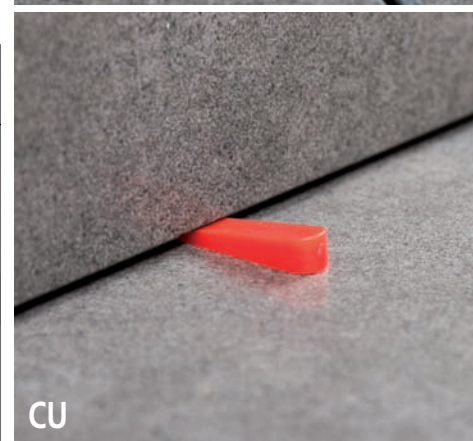

CU

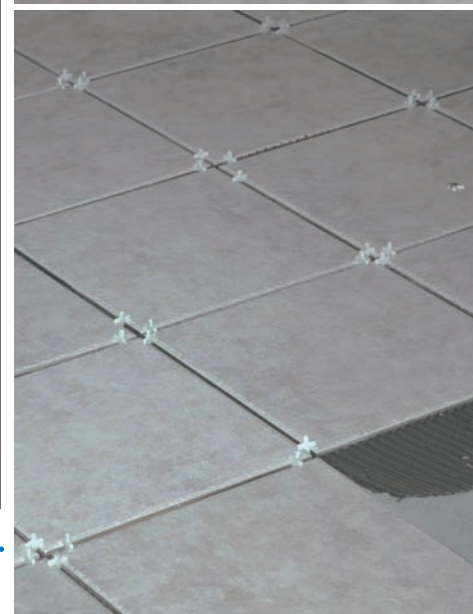

Precio/Price: € /Bolsa

Referencia Reference	Ancho	Width	U/bolsa U/bag	Bolsas/caja Bags/box	€/bolsa €/bag
C1	1 mm	1/24"	250	150	2,50
C2	2 mm	3/32"	250	250	2,50
C3	3 mm	1/8"	250	200	2,69
C4	4 mm	5/32"	250	90	4,05
C5	5 mm	3/16"	200	75	3,51
C6	6 mm	1/4"	200	65	3,62
C8	8 mm	5/16"	200	50	4,05
C10	10 mm	3/8"	100	50	4,31
T4	4 mm	5/32"	250	300	4,05
T5	5 mm	3/16"	200	300	3,54
T6	6 mm	1/4"	200	300	3,62
T8	8 mm	5/16"	200	220	4,05
T10	10 mm	3/8"	100	170	4,31
CU	1-5 mm	1/24"-3/16"	250	200	4,12
C2PLUS	2 mm	3/32"	100	100	3,91
C3PLUS	3 mm	1/8"	100	100	4,24
C5PLUS	5 mm	3/16"	100	100	4,73





Soluciones de herramientas para profesionales de la construcción y la reforma.
Tool solutions for construction professionals and renovation.



Europaleta PRO+

ES Paleta redonda. Acero de alta calidad, flexibilidad y resistencia. Mango confort bicomponente ergonómico.

EN Round trowel. High-quality steel, flexibility and durability. Comfortable dual-component ergonomic handle.



PRO+ 1000

Referencia Reference	Medida Size	u. / Caja u. / Box	Precio/Price €/u.
1000	200 mm	10	10,25



PRO+ 1020

Referencia Reference	Medida Size	u. / Caja u. / Box	Precio/Price €/u.
1020	170 mm	10	11,60



Europaleta PRO+ 1010

ES Paleta cuadrada, 180 mm. Acero de alta calidad, flexibilidad y resistencia. Mango confort bicomponente ergonómico.

EN Square trowel, 180 mm. High-quality steel, flexibility and durability. Comfortable dual-component ergonomic handle.

Referencia Reference	Medida Size	u. / Caja u. / Box	Precio/Price €/u.
1010	180 mm	10	11,60







Eurollana INOX PRO+



ES Llana dentada. Acero inoxidable de alta calidad, flexibilidad y resistencia. Mango confort bicomponente ergonómico.

EN Serrated flooring trowel. High-quality steel, flexibility and durability. Comfortable dual-component ergonomic handle.



Referencia Reference	Medida Size	u. / Caja u. / Box	Precio/Price €/u.	
1106	 6 x 6 mm	280 x 115 mm	10	14,85
1108	 8 x 8 mm	280 x 115 mm	10	14,85
1110	 10 x 10 mm	280 x 115 mm	10	14,85
1112	 12 x 12 mm	280 x 115 mm	10	14,85



Referencia Reference	Medida Size	u. / Caja u. / Box	Precio/Price €/u.	
1160	 10 x 10 mm	480 x 130 mm	5	26,95
1162	 12 x 12 mm	480 x 130 mm	5	26,95

Eurollana INOX PRO+

ES Llana lisa. Acero inoxidable de alta calidad, flexibilidad y resistencia. Mango confort bicomponente ergonómico.

EN Plain trowel. High-quality steel, flexibility and durability. Comfortable dual-component ergonomic handle.



Referencia Reference	Medida Size	u. / Caja u. / Box	Precio/Price €/u.	
1100	 LISA	280 x 130 mm	10	15,54



Referencia Reference	Medida Size	u. / Caja u. / Box	Precio/Price €/u.	
1150	 LISA	480 x 130 mm	5	26,95



EUROHERRAMIENTAS

Eurollana RASCADOR PRO+ 1180

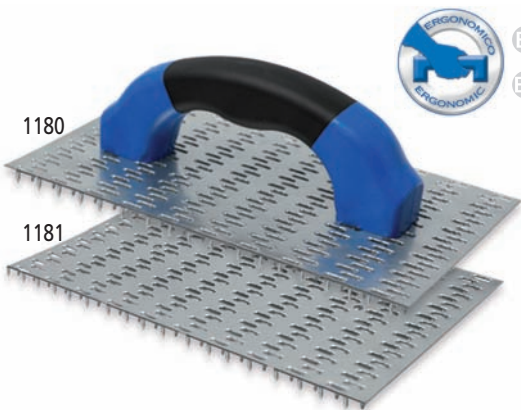

ES Llana rascador. Mango confort bicomponente ergonómico.

EN Scraping trowel. Ergonomic handle.

Referencia Reference	Medida Size	u. / Caja u. / Box	Precio/Price €/u.
1180	250 x 145 x 8 mm	10	11,00
1181 Recambio Replacement	250 x 145 x 8 mm	10	5,50



Eurollana GOMA+EVA PRO+ 1200

ES Llana de goma + EVA de alta densidad para juntas. Mango confort ergonómico.

EN High-density rubber + EVA grout float. Comfortable ergonomic handle.

Referencia Reference	Medida Size	u. / Caja u. / Box	Precio/Price €/u.
1200	240 x 100 mm	12	15,40



Eurollana GOMA BLANDA PRO+ 1220

ES Llana de Goma blanda de doble péfil. Apta para epoxy.

EN Soft double-edged rubber float. Suitable for epoxy.

Referencia Reference	Medida Size	u. / Caja u. / Box	Precio/Price €/u.
1220	248 x 116 mm	12	14,40



EUROHERRAMIENTAS

Euroespatula Goma PRO+ 1250

ES Espatula de goma para juntas.

EN Rubber grout spreader.



Referencia Reference	Medida Size	u. / Caja u. / Box	Precio/Price €/u.
1250	300 mm	10	6,13

Euroregleta EVA PRO+ 1260

ES Regleta doble EVA reforzada.

EN Dual EVA reinforced power strip.

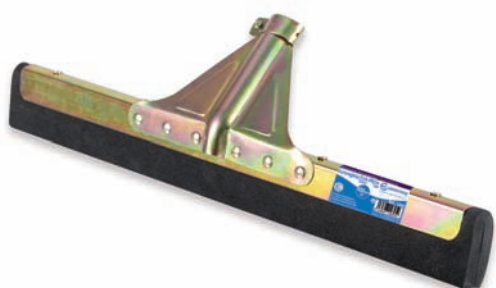

Referencia Reference	Medida Size	u. / Caja u. / Box	Precio/Price €/u.
1260	450 mm	10	14,44
1265	750 mm	10	22,68

Euromango extensible PRO 1270

ES Mango aluminio anodizado extensible 80-140cm.

EN Expandable anodised aluminium handle 80-140cm.



Referencia Reference	Medida Size	u. / Caja u. / Box	Precio/Price €/u.
1270	800 a 1400 mm	20	14,50



Eurollana CLEAN Set 3 PRO+ 1400

ES Lana con 3 estropajos fino, medio y fuerte. Ideal para azulejos, piedra natural y todo tipo de juntas. Mango confort bicomponente ergonómico.

EN Grout float with 3 cleaning pads, fine, medium and rough. Ideal for tiles, natural stone, and all types of joints. Comfortable dual-component ergonomic handle.

Referencia Reference	Medida Size	u. / Caja u. / Box	Precio/Price €/u.
1400	250 x 120 x 25 mm x 3 (Fino, Medio y Fuerte)	10	18,75
1401	250 x 120 x 25 mm (Fino)	10	3,57
1402	250 x 120 x 25 mm (Medio)	10	3,57
1403	250 x 120 x 25 mm (Fuerte)	10	3,57



Eurocubo 24 L. CLEAN PRO+ 1460

ES Cubo limpieza 24 Litros, doble rodillo escurridor, rejilla de goteo y cuatro ruedas.

EN 24-litre cleaning bucket, double roller wringer, splash guard and four wheels.

Referencia Reference	Medida Size	u. / Caja u. / Box	Precio/Price €/u.
1460	24 Litros	6	54,46



Eurorascador PRO+ 1450

ES Rascador para juntas + 2 hojas de carburo de gran resistencia a la abrasión. Mango ergonómico antideslizante.

EN Grout scraper + 2 highly abrasion-resistant carbide blades. Ergonomic anti-slip handle.

Referencia Reference	Observaciones Observations	u. / Caja u. / Box	Precio/Price €/u.
1450		10	8,25
1451	Pack 3 u.	12	4,90

Euroespatula INOX PRO+ 1440/1441

ES Espatula acero inoxidable de alta calidad flexibilidad y resistencia.

EN High quality and resistant stainless steel spatula.

Referencia Reference	Medida Size	u. / Caja u. / Box	Precio/Price €/u.
1440	100 mm	12	7,05
1441	150 mm	12	8,65

Euronivel PRO+ 1700/1705

ES Aluminio reforzado. 3 burbujas de alta visibilidad y precisión. Magnético. Bases mecanizadas. Antishock. 2 empuñadoras ergonómicas.

EN Reinforced aluminium. 3 high visibility and precision bubbles. Magnetic. Mechanised bases. Anti-shock. 2 ergonomic handles

Referencia Reference	Medida Size	u. / Caja u. / Box	Precio/Price €/u.
1700	600 mm	20	33,00
1705	1000 mm	20	45,23

Euomaceta PRO+ 1510/1520

ES Maceta de acero templado. Mango de fibra de vidrio bicomponente ergonómico.

EN Tempered stell mallet. Glass fiber comfortable dual-component ergonomic handle.

Referencia Reference	Medida Size	u. / Caja u. / Box	Precio/Price €/u.
1510	700 gr.	6	20,35
1520	1000 gr.	6	21,17

Euomaza PRO+ 1500

ES Maza de goma blanca. Mango confort bicomponente ergonómico.

EN White rubber mallet. Comfortable dual-component ergonomic handle.

Referencia Reference	Medida Size	u. / Caja u. / Box	Precio/Price €/u.
1500	450 gr.	6	13,10
1501	900 gr.	6	20,99



Euroventosa 1550/1552

- ES Ventosa para levantar o mover superficies planas como cerámica, marmol o cristal durante su instalación.
- EN Suction cup for lifting or moving flat surfaces, such as ceramics, marble or glass during installation.

Referencia Reference	Medida Size	u. / Caja u. / Box	Precio/Price €/u.
1550	Ø 120 mm - Max. 35 kg.	12	10,69
1552	Doble Ø 120 mm - Max. 60 kg.	5	19,32



Eurorodillera GEL PRO+ 1600

- ES Rodillera Gel máxima comodidad y confort. Diseño ergonómico de neopreno.
- EN Knee pad-Gel type, maximum comfort and convenience. Ergonomic neoprene design.

Referencia Reference	Observaciones Observations	u. / Caja u. / Box	Precio/Price €/u.
1600	Pack 2 u.	12	34,43



Eurovarilla MIX 3H 1800/1801

- ES Varilla mezcladora para mortero y cola profesional. Conexión M14.

Referencia Reference	Medida Size	u. / Caja u. / Box	Precio/Price €/u.
1800	Ø 115 x 600 mm - Conexión M14	6	22,27
1801	Ø 140 x 600 mm - Conexión M14	6	25,23



Eurobroca DIAMOND/DRY PRO+ 1950

- ES** Broca de diamante para corte en seco con taladro. Para materiales duros como porcelánico, cerámica, mármol, granito, etc. Fabricada con la tecnología VACUUM BRAZED, para que la soldadura entre el diamante y la corona sea más duradera. Para una mayor durabilidad se aconseja alternar el corte con giro en vacío para refrigerar la broca.
- EN** Diamond bit for dry cutting with a drill. For hard materials such as porcelain, ceramics, marble, granite, etc. Manufactured with VACUUM BRAZED technology so that the weld between the diamond and the crown is more long-lasting. For a greater durability, we advise alternating the cut with a free rotation to cool the bit.



Referencia Reference	Medida Size	U. / Caja U. / Box	Precios/Price €/u.
1950/6	ø 6 mm	10	17,87
1950/8	ø 8 mm	10	17,87
1950/10	ø 10 mm	10	19,25
1950/12	ø 12 mm	10	19,25

Eurocorona DIAMOND/DRY PRO+ 1900

- ES** Corona de diamante para corte en seco. Para materiales duros como porcelánico, cerámica, mármol, granito, etc. Fabricada con la tecnología VACUUM BRAZED, para que la soldadura entre el diamante y la corona sea más duradera. Para una mayor durabilidad se aconseja alternar el corte con giro en vacío para refrigerar la broca.
- EN** Diamond crown for dry cutting. For hard materials such as porcelain, ceramics, marble, granite, etc. Manufactured with VACUUM BRAZED technology so that the weld between the diamond and the crown is more long-lasting. For a greater durability, we advise alternating the cut with a free rotation to cool the bit.

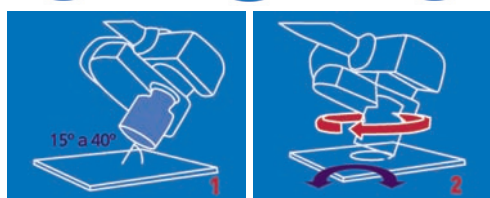

Referencia Reference	Medida Size	Profundidad Depth	Conexión Connection	U. / Caja U. / Box	Precios/Price €/u.
1900/6	ø 6 mm	30 mm	M14	10	18,50
1900/8	ø 8 mm	30 mm	M14	10	18,50
1900/10	ø 10 mm	30 mm	M14	10	19,00
1900/12	ø 12 mm	30 mm	M14	10	19,00
1900/20	ø 20 mm	35 mm	M14	10	32,50
1900/28	ø 28 mm	35 mm	M14	10	38,00
1900/35	ø 35 mm	35 mm	M14	10	45,00
1900/43	ø 43 mm	35 mm	M14	5	52,50
1900/50	ø 50 mm	35 mm	M14	5	62,50
1900/55	ø 55 mm	35 mm	M14	5	68,50
1900/60	ø 60 mm	35 mm	M14	5	74,50
1900/65	ø 65 mm	35 mm	M14	5	78,50
1900/68	ø 68 mm	35 mm	M14	5	82,50
1900/75	ø 75 mm	35 mm	M14	5	88,50

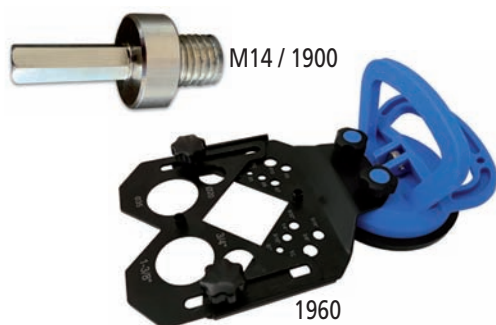

M14 / 1900	Conexión M14 para Taladro 1900	10,00
1960	Euroguía DIAMOND/DRY (ø + MAX 83 mm)	50,00



Eurodisco TURBO PRO+ 1980

- ES** Disco de acero con corte de diamante. Eje reforzado. Para materiales duros como porcelánico, cerámicos duros, pizarra, refractarios, granito, klinker, etc. Cumple la normativa europea EN13236.
- EN** Steel disc with diamond cut. Reinforced shaft. For hard materials such as porcelain, hard ceramics, slate, fireproof materials, granite, clinker, etc. Complies with European standard EN13236.



Referencia Reference	Medida Size	Eje Shaft	h: Segmento h: Segment	a: Segmento a: Segment	u. / Caja u. / Box	Precio/Price €/u.
1980/115	Ø 115 mm	Ø 22,2 mm	7 mm	1,6 mm	10	27,07
1980/125	Ø 125 mm	Ø 22,2 mm	7 mm	1,6 mm	10	28,36
1980/230	Ø 230 mm	Ø 22,2 mm	7 mm	1,6 mm	10	73,08

Eurodisco CYCLON PRO+ 1990

- ES** Disco de acero con corte de diamante. Eje reforzado. Para materiales duros como porcelánico, cerámicos duros, pizarra, refractarios, granito, klinker, tejas, piedra natural, gres rústico, marmoles etc. Cumple la normativa europea EN13236.
- EN** Steel disc with diamond cut. Reinforced shaft. For hard materials such as porcelain, hard ceramics, slate, fire proof materials, granite, clinker, tiles, natural stone, rustic stoneware, marble, etc. Complies with European Standard EN13236.



Referencia Reference	Medida Size	Eje Shaft	h: Segmento h: Segment	a: Segmento a: Segment	u. / Caja u. / Box	Precio/Price €/u.
1990/115	Ø 115 mm	Ø 22,2 mm	10 mm	1,4 mm	10	33,51
1990/125	Ø 125 mm	Ø 22,2 mm	10 mm	1,4 mm	10	38,34



Mosaico autoadhesivo de fácil colocación para la renovación de ambientes de interior (paredes, baños y cocinas), sin necesidad de obras ni de profesionales.

Self-adhesive, easy to lay mosaic to renovate interior ambiances (walls, bathrooms and kitchens) without the need for work by professionals.



EUROMOSAICO AUTOADHESIVO



¡DESPEGAR, COLOCAR Y PRESIONAR: LISTO!! • ¡UNSTICK, PLACE AND PRESS: READY!! • ¡DECOLLER, POSER ET APPUYER: C'EST FAIT!!

ES EUROMOSAICO AUTOADHESIVO, Mosaico autoadhesivo de fácil colocación para la renovación de ambientes de interior (paredes, baños y cocinas), sin necesidad de obras ni de profesionales.

Modo de uso:

- 1• Asegurarse que la pared está perfectamente limpia y seca antes de la colocación del mosaico. En superficies rugosas o porosas, se recomienda colocar una capa de imprimación y dejarla secar completamente. En caso de que la pared esté dañada, reparar previamente a la colocación del mosaico
- 2• Medir y planificar el diseño antes de empezar. Se recomienda trazar unas líneas sobre la superficie para usar como guía de colocación. Antes de pegar asegurar que la posición es correcta, pues una vez colocada la malla de mosaico es muy difícil de despegar.
- 3• Retirar la lámina posterior, colocar el mosaico sobre la superficie y presionar firmemente.
- 4• Para mallas con separaciones entre piezas, borrar el producto. Inmediatamente después limpiar con un paño suave el exceso de borada, para evitar que la malla pueda dañarse. (Respete las instrucciones del fabricante de la borada para su colocación)

MATERIAL NECESARIO: Esponja, nivel, cutter / tijera y metro.

⚠ ATENCIÓN. Producto exclusivo para interiores. No aplicar el producto sobre superficies que tengan base de látex, vinilo o acetatos de Polivinilos (PVA)

EN EUROSELF-ADHESIVE MOSAIC, Self-adhesive, easy to lay mosaic to renovate interior ambiances (walls, bathrooms and kitchens) without the need for work by professionals.

How to use:

- 1• Make sure that the wall is absolutely clean and dry before placing the mosaic. For rough and porous surfaces, it is recommended to apply a priming layer that is allowed to fully dry. If the wall is damaged, effect repairs before placing the mosaic.
- 2• Measure and plan the design before beginning. It is recommended that lines be drawn on the surface that can be used as a placement guide. Before attaching, make sure that they are correctly positioned, since it is very difficult to unstick the mosaic once it has been applied.
- 3• Remove the back layer, place the mosaic on the surface, and press firmly.
- 4• For grids with spaces between pieces, apply glue cement to the product. Immediately after this, wipe the excess glue cement away with a soft cloth to avoid damaging the mosaic. (Follow the glue cement manufacturer's instructions for application).

MATERIAL REQUIRED: Sponge, spirit level, cutter / scissors and metre stick.

⚠ TAKE CARE. Product exclusively for interiors. Do not apply the product on surfaces with a latex, vinyl, or polyvinyl acetate (PVA) base

Ref. Ref.	Ancho (a) Width (a)	Altura (h) Height (h)	€/ u.	U / Caja U / Box	Ref. Ref.	Ancho (a) Width (a)	Altura (h) Height (h)	€/ u.	U / Caja U / Box
MOSAICO A01 / AD Metal 1	305 x 305 mm. 12" x 12"	4 mm. 0,16"	10,31	22	MOSAICO A08 / AD Stone Grey	300 x 300 mm. 11,8" x 11,8"	4 mm. 0,16"	11,84	22
MOSAICO A02 / AD Metal 2	305 x 305 mm. 12" x 12"		10,31		MOSAICO A09 / AD Stone Beige	300 x 300 mm. 11,8" x 11,8"		11,84	
MOSAICO A03 / AD Metal 3	305 x 305 mm. 12" x 12"		10,31		MOSAICO A10 / AD Stone Oxido	300 x 300 mm. 11,8" x 11,8"		11,84	
MOSAICO A04 / AD Metal + Cristal	305 x 305 mm. 12" x 12"		10,31		MOSAICO A11 / AD Stone Black	300 x 300 mm. 11,8" x 11,8"		11,84	
MOSAICO C05 / AD Glass + Stone Beige	300 x 300 mm. 11,8" x 11,8"		10,31		MOSAICO C12 / AD Roble	300 x 300 mm. 11,8" x 11,8"		12,45	
MOSAICO C06 / AD Glass + Stone Blanco	300 x 300 mm. 11,8" x 11,8"		10,31		MOSAICO C13 / AD Madera Gris	300 x 300 mm. 11,8" x 11,8"		12,45	
MOSAICO C07 / AD Glass + Stone Negro	300 x 300 mm. 11,8" x 11,8"		10,31		MOSAICO C14 / AD Nogal	300 x 300 mm. 11,8" x 11,8"		12,45	

(AD) Autoadhesivo / Self adhesive



Serie Glass + Stone

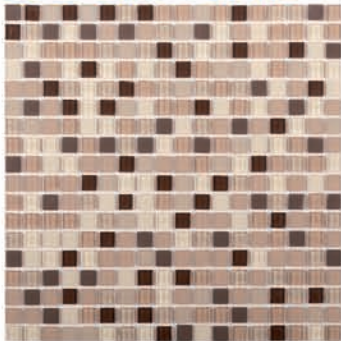

C05 / AD Glass + Stone Beige

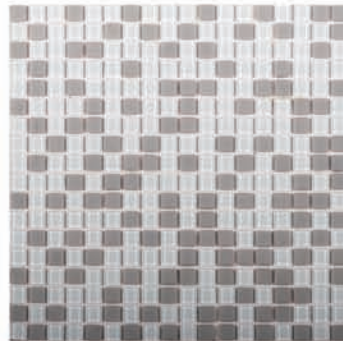

C06 / AD Glass + Stone Blanco



C07 / AD Glass + Stone Negro



Serie Metal (Aluminio / Aluminium)

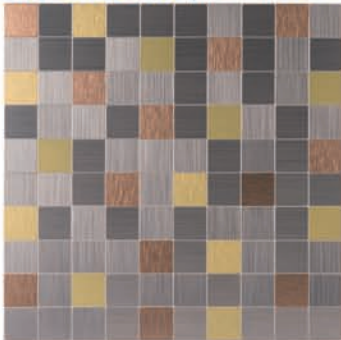

A01 / AD Metal 1



A02 / AD Metal 2



A03 / AD Metal 3

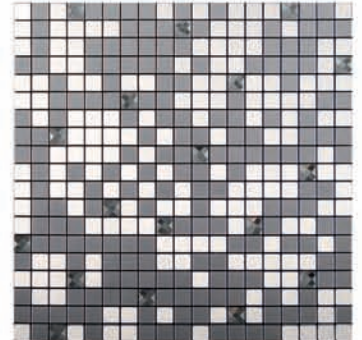

A04 / AD Metal + Cristal

Serie Stone (Pvc de alta resistencia, imitación piedra / Pvc high resistance, stone imitation / Pvc haute résistance, imitation pierre)

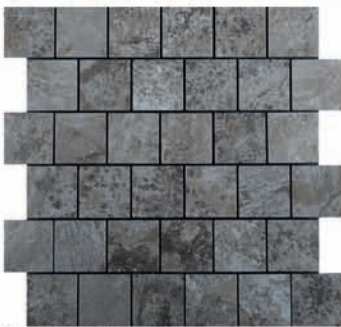

A08 / AD Stone Grey



A09 / AD Stone Beige



A10 / AD Stone Oxido



A11 / AD Stone Black

Serie Madera (Pvc de alta resistencia, imitación madera / Pvc high resistance, wood imitation / haute résistance, similibois Pvc)



A12 / AD Roble

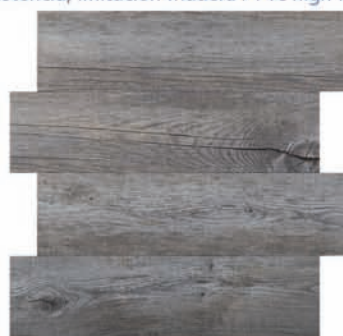

A13 / AD Madera Gris



A14 / AD Nogal

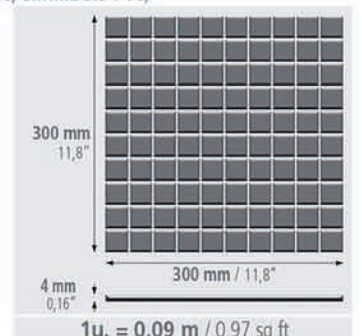

Gama de color PVC

PVC range of colours



Blanco (BL)

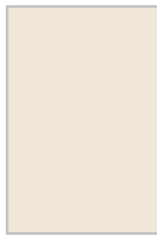

Crema (CR)



Champagne (CH)



Beige-G (BG)

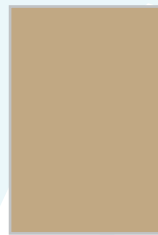

Beige (BE)



Marron (MA)

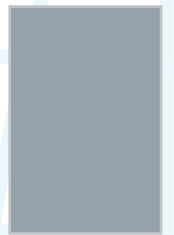

Gris claro (GC)



Gris (GR)



Negro (NE)

Gama Decorados PVC

PVC Decoration range



M. Blanco (MBL)



M. Crema (MCR)



M. CF (MCF)

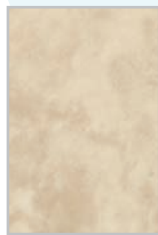

M. CD (MCD)

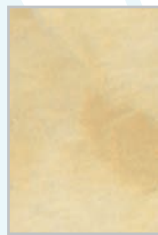

M. CB (MCB)



M. Marron (MMA)

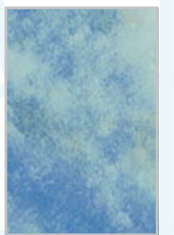

M. AB (MAB)



Roble (RO)

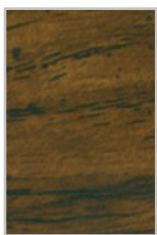

Nogal (NO)

Gama de Rústicos TEXTURA PVC + FN

TEXTURA Rustic range PVC + NF



Textura Blanco (TX/BL)



Textura Beige (TX/BG)



Textura Marron claro (TX/MC)



Textura Marron (TX/MA)



Textura Ceniza (TX/CE)



Textura Pizarra (TX/PIZ)



Textura Negro (TX/NE)

La impresión de las gamas de colores difieren ligeramente de los colores originales. Solicitar catálogo de muestras físicas
The printing of the colour range is highly different of the original. Please ask for our folder with the complete colour range.

Gama de Rústicos PVC + FN

Rustic range PVC + NF



Blanco (BL)



Crema (CR)



Hueso (HU)

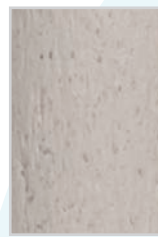

Champagne (CH)

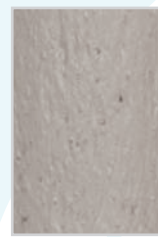

Beige G (BG)



Caramelo (CAR)



Teja (TE)



Marron claro (MC)



Tierra (TI)

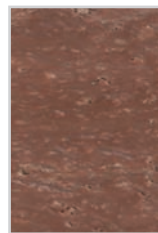

Madera (MAD)

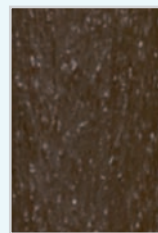

Marron (MA)

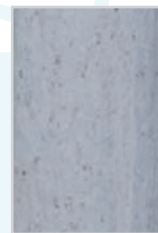

Gris (GR)



Ceniza (CEN)

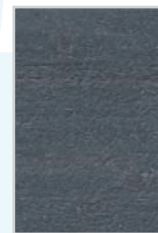

Grafito (GFT)



Pizarra (PIZ)

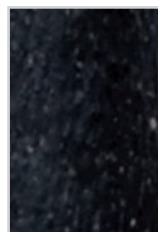

Negro (NE)

Gama Acero Inoxidable

Stainless Steel range



Inox brillo (IB)



Inox cepillado (IC)



Negro brillo (NEB)



Negro cepillado (NEC)



Cobre brillo (COB)



Cobre cepillado (COC)



Oro brillo (OB)



Oro cepillado (OC)



Old bronze (OLBR)



Old cooper (OLCO)

La impresión de las gamas de colores difieren ligeramente de los colores originales.
Solicitar catálogo de muestras físicas
The printing of the colour range is highly different of the original.
Please ask for our folder with the complete colour range.

Gama de Aluminio

Aluminium range



Blanco (BL)

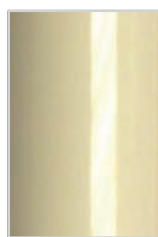

Crema (CR)



Plata brillo (PB)



Plata mate (PM)



Plata cepillado (PC)

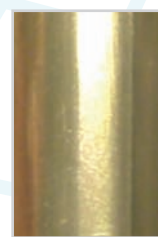

Oro brillo (OB)

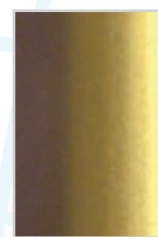

Oro mate (OM)



Negro mate (NM)



Negro brillo (NEB)



Bronce mate (BRM)

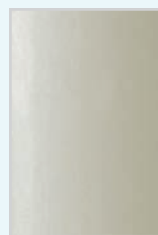

Champagne brillo (CHB)

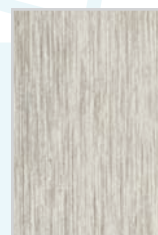

Champagne cepillado (CHC)

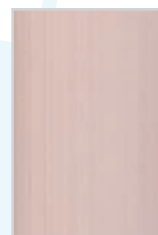

Oro rosa brillo (ORS)



Oro rosa cepillado (ORC)



Arena camel (ARCA)

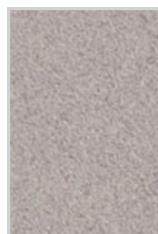

Arena G. claro (ARGC)



Arena gris (ARGR)

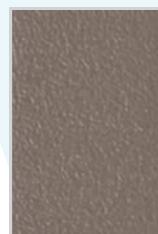

Arena marrón (ARMA)



Arena óxido (AROX)

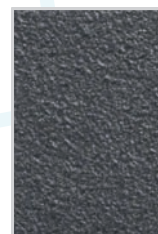

Arena antracita (ARAN)

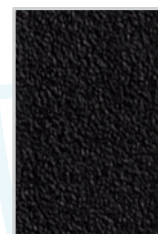

Arena negro (ARNE)



Blanco 2 (BL2)

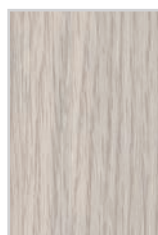

Roble claro (RC)



Haya (HA)

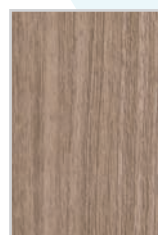

Roble natural (RN)



Roble (RO)

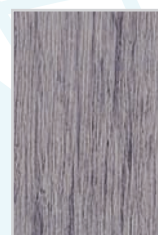

Madera G. claro (MGC)



Madera gris (MG)



Cerezo (CE)

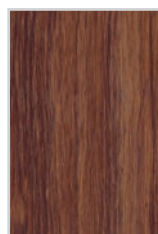

Sapelly (SA)



Nogal satinado (NS)



Nogal (NO)

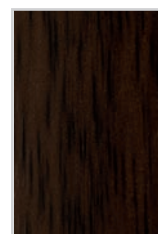

Wenge (WE)

Gama Latón

Brass range



Latón cromado (CRO)

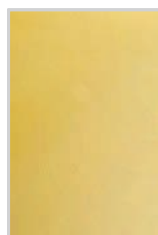

Latón natural (NAT)



Antique bronze (ABR)



Antique cooper (ACO)

La impresión de las gamas de colores difieren ligeramente de los colores originales. Solicitar catálogo de muestras físicas
The printing of the colour range is highly different of the original. Please ask for our folder with the complete colour range.

Material publicitario y muestras

Catalogue and samples folders.

35€ (x 5)



Muestrarios perfiles / Sample profiles:
CAT 1/5 PVC
CAT 2/5 Angulos y Cantoneras / Listelos
CAT 3/5 Peldaños
CAT 4/5 Transiciones / Juntas Dilatación
CAT 5/5 LED / Vierteagüas / Escocias / Zócalos
 CAT 1/5 PVC
 CAT 2/5 Corners and Edges / Listellos
 CAT 3/5 Stair-Nosing
 CAT 4/5 Transitions / Expansion Joint
 CAT 5/5 LED / Balcony / Cove-Shaped / Skirting



M-ECO: muestras gama ECO171A, ECO212A/SM-
 M-ECO: samples ECO171A, ECO212A/S



M-RUSTICOS 212R: Euromultipusos
 M-RUSTIC 212R: Euromultipurpose



M-RUSTICOS 245R/254R/268R: Europeldaños
 M-RUSTIC 245R/254R/268R: Eurosteps



M-RUSTIC TEXTURA 212R/TX: Euromultipusos
 M-RUSTIC TEXTURA 212R/TX: Euromultipurpose



M-RUSTIC TEXTURA 245R/268R/TX: Europeldaños
 M-RUSTIC TEXTURA 245R/268R/TX: Eurosteps

Material publicitario y muestras

Catalogues and samples

490€



MAQUETA LED
MAQUETA LED

45€



M-ARCHITECT: muestras perfiles arquitectos
M-ARCHITECT: architect samples

25€



Display 100E - Listelos / LED
Display 100E - Listellos / LED

45€



Display 100E-183A/S/L
Display 100E-212A/S/L

6€



M-WEDGE LEVEL: Muestras
M-WEDGE LEVEL: Samples

Maqueta A, B y C
Demo tape A, B and C
Medida 0,4 x 0,4 x 0,3m



450€



450€



450€

Expositores. Exhibitors.

267€



Expositor: 205E-NE
Exhibitor: 205E-NE
Anchura: 1m / Altura: 1,90m
Profundidad: 0,63m Espacios: 18

383€



Expositor: 205-LM reforzado DIY
Exhibitor: 205-LM reinforced for DIY
Anchura: 1m / Altura: 1,90m
Profundidad: 0,63m / Espacios: 18

36,70 €

Gancho crucetas
Crosspieces hanger



Expositor:
Exhibitor: 109E
Altura: 0,80 m
Espacios: 3

52,50 €



Trans 205E complemento ref. 205
Trans 205E complement ref. 205
Anchura: 0,5m Espacios: 9
Color: Blanco, Negro

390€

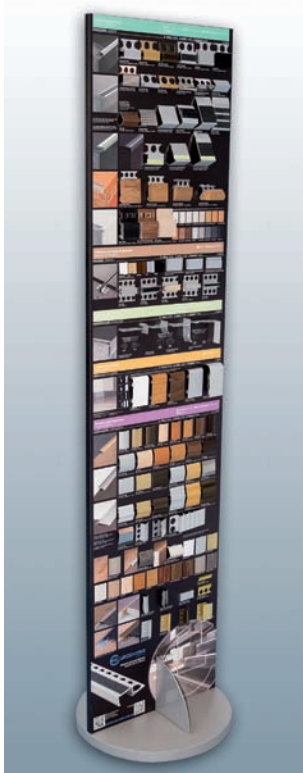

Expositor: 107E-NE
Exhibitor: 107E-NE
Anchura: 0,40m / Altura: 1,70m
Profundidad: 0,40m

283€



Expositor: EXP.LEVELLING/NE
Exhibitor: EXP.EUROLEVELLING/NE
Anchura: 0,98m / Altura: 1,90m
Profundidad: 0,50m

400€



Expositor: EXP.TOOLS
Exhibitor: EXP.TOOLS
Anchura: 1m / Altura: 2,2m
Profundidad: 0,50m

- ES** La empresa se reserva el derecho de modificación por actualización o mejoras de sus productos.
- EN** The company reserves the right to modify by updating or improving its products.
- FR** La société se réserve le droit de modifier en mettant à jour ou en améliorant ses produits.
- DE** Das Unternehmen behält sich das Recht vor, Änderungen durch Aktualisierung oder Verbesserung seiner Produkte vorzunehmen.

PVC

Polímero termoplástico no inflamable con unas magníficas propiedades mecánicas. Es un material dúctil y tenaz que presenta gran estabilidad dimensional y resistencia ambiental. Por todas estas características, el PVC tiene una gran cantidad de aplicaciones en el mundo de la construcción.

Nuestros perfiles de PVC son producidos bajo un exhaustivo proceso de calidad, manteniendo siempre con gran exactitud cada uno de nuestros colores, así como su característica flexibilidad y resistencia.

El PVC puede ser limpiado con los productos comunes del mercado, no obstante se recomienda no utilizar productos abrasivos en los perfiles decorados, pues podría alterarse su aspecto.

Finalmente queremos remarcar que el PVC es un material altamente reciclable.

PVC Rustic: PVC especial con fibras naturales recicladas, PVC + FN

PVC

Non-inflammable thermoplastic polymer with great mechanical properties. A ductile and persistent material with a great dimensional stability and environmental resistance. Because of all these characteristics it is applied in many ways in the building industry.

Our PVC profiles are produced undergoing an exhaustive quality management process, always preserving all of our colours with great precision, as well as their characteristic flexibility and resistance.

Although PVC can be cleaned with the common cleaning products that exist on the market, it is not advisable to use abrasive products on decorated profiles, because they can change their look.

Finally, we would like to point out that a high percentage of PVC can be recycled.

PVC Rustic: PVC including natural recycled fibers, PVC + FN

PVC

Polymère thermoplastique non inflammable ayant des magnifiques propriétés mécaniques. C'est un matériel souple et tenace qui présente une grande stabilité dimensionnelle et une résistance environnementale. Voilà pourquoi, le PVC possède une grande quantité d'applications dans le monde de la construction.

Nos profilés en PVC sont réalisés sous un exhaustif contrôle de qualité, en maintenant toujours avec exactitude chacune de nos couleurs, ainsi que sa caractéristique flexibilité et résistance. Le PVC peut être nettoyé avec des produits courants dans le marché, cependant nous recommandons de ne pas utiliser des produits abrasifs sur les profilés décorés car leur aspect pourrait être modifié.

Enfin, nous voudrions insister sur le fait que le PVC est un matériel hautement recyclable.

PVC Rustic: PVC spécial avec des fibres naturelles recyclables, PVC + FN

PVC - Kunststoff

Es handelt sich um unentzündbares thermoplastisches Polymer mit hervorragenden mechanischen Eigenschaften. Dieses Material ist biegsam und zäh und zeichnet sich durch seine hohe Dimensionsstabilität und Umweltbelastbarkeit aus. Aufgrund dieser Qualitäten findet PVC-Kunststoff im Baugewerbe viele Anwendungsmöglichkeiten.

Unsere PVC-Kunststoffprofile werden gründlichen Qualitätskontrollen unterzogen, ohne dabei weder die Farbqualität noch die charakteristische Biegsamkeit und Belastbarkeit im Mindesten zu beeinträchtigen.

PVC-Kunststoff kann mit den handelsüblichen Produkten gereinigt werden. Dennoch empfehlen wir, keine Schleifmittel bei verzierten Fliesen zu benutzen, weil sie dem Aussehen schaden können.

Nicht zuletzt ist hervorzuheben, dass PVC-Kunststoff sehr gut wiederverwendet werden kann.

PVC Rustic: PVC-Kunststoff aus wiederverwerteten Naturfasern angefertigt.

MADERA NATURAL (N)

Los perfiles de madera aportan calidez y elegancia, creando ambientes con un toque noble y acogedor. Para nuestros perfiles hemos utilizado dos tipos de madera tropical que se caracterizan por su dureza y su alta resistencia a los cambios climáticos y al paso del tiempo:

AYOUS: recomendado para su uso interior, puede presentar variaciones de color en función de la pieza de madera de donde provenga.

IROKO: madera que se puede usar tanto en exteriores como en interiores, debido a sus altas propiedades físicas como mecánicas, y a su alta resistencia a la flexión estática, a la compresión y a la tracción paralela.

Su color puede variar sutilmente con el tiempo, por su exposición a la luz solar.

Se suministra en estado natural, por lo que una vez colocado se tiene que tratar con algún producto, como aceite natural ó barniz.

NATURAL WOOD (N)

Wood is a noble material that gives warmth and elegance, creating cozy atmospheres. We have used two kinds of tropic wood for our profiles that are characterized by its hardness and high resistance to climate changes or the effects of time.

AYOUS: Recommended for indoors, can present colour variations depending on the place where piece of wood comes from.

IROKO: Type of wood that can be used both outdoors and indoors due to its excellent physical and mechanical properties, like resistance to static flexion, compression and parallel traction.

In the course of time, the colour may present subtle variations because of the exposure to sunlight.

As it is shipped without processing, it has to be treated with a product like natural oil or varnish once it is applied.

BOIS NATUREL (N)

Les profils en bois sont chaleureux et élégants. Ils créent des milieux nobles et accueillants.

Nous avons utilisé pour nos profilés deux types de bois tropical qui se caractérisent pour leur dureté et leur résistance aux changements climatiques et à l'usure du temps.

AYOUS: recommandé pour un usage intérieur, il peut avoir des variations de couleur en fonction de l'endroit d'où provient le morceau de bois.

IROKO: bois qui peut être utilisé à l'intérieur comme à l'extérieur car il possède des propriétés physiques et mécaniques, il est résistan à la flexion statique, à la compression et à la traction parallèle.

A cause de son exposition au soleil sa couleur peut changer légèrement avec le temps.

Il est fourni à l'état naturel, ce qui veut dire que suite à son installation il doit être traité avec un produit, comme l'huile naturelle ou le vernis.

NATURHOLZ (N)

Profil aus Holz machen Räume warm und elegant und schaffen eine edle und gemütliche Atmosphäre. Für unsere Profileisten haben wir zwei Arten von Tropenholz benutzt, das sich durch seine Härte und hohen Widerstand gegenüber Klimaveränderungen und Alterungsprozesse auszeichnet:

AYOUS: Empfehlenswert für Inneneinrichtungen. Die Farbtöne des Holzes können je nach Herkunft unterschiedlich sein.

IROKO: Wegen seiner ausgezeichneten physischen und mechanischen Eigenschaften, seinem hohen Widerstand gegen statische Biegung, Verdichtung und paralleler Druckfestigkeit kann dieses Holz sowohl im Innen- als auch im Außenbereich angewendet werden.

Die Farbe des Holzes kann sich mit der Zeit und dem Einfluss des Sonnenlichts leicht verändern.

Die Profileisten aus Holz werden unbehandelt geliefert. Deshalb sollten sie nach dem Einbau mit Öl oder Beizmitteln bearbeitet werden.

ALUMINIO. (A)

El aluminio posee una combinación de propiedades que lo hacen muy útil en la rama de la construcción, tales como su alta resistencia a la corrosión, su ligereza y su ductilidad. El Aluminio natural por sí mismo, en contacto con el aire forma rápidamente una fina capa superficial de óxido de aluminio impermeable y adherente, que detiene el proceso de oxidación, lo que hace que sea un material resistente a la corrosión y más duradero. No obstante para incrementar estos efectos y darles un acabado más decorativo, el Aluminio se somete a procesos de acabado especiales, como:

- ANODIZADO : Plata brillo (PB), Plata mate (PM), Oro brillo (OB), Oro mate (OM), Plata cepillado (PC), Bronce mate (BRM) y Negro mate (NM)
- LACADO: Blanco (BL), Crema (CR) y Gris claro (GC).
- CROMADO (CRO)

Los perfiles de aluminio se limpian fácilmente con cualquier producto habitual de limpieza, no obstante se recomienda no usar lana de acero, limpiadores ácidos o abrasivos (salfumán, lejía, etc), pues podrían deteriorar o rayar los perfiles.

Para conservar perfectamente el acabado decorativo que caracteriza a este material, es indispensable limpiar los perfiles inmediatamente después de su colocación, eliminando cualquier resto de cemento o de otro material usado para la fijación del perfil.

El Aluminio es un material 100% reciclable sin merma de sus cualidades.

ALUMINIUM. (A)

This metal possesses a combination of properties which make it very useful in the building industry, for example, its high resistance to corrosion, its lightness and ductility. When getting into contact with air, natural aluminium quickly forms a thin superficial layer of waterproof and adhesive aluminium oxide, which stops the oxidation process. This makes it highly resistant to corrosion and adds to the durability. However, in order to enhance these effects and give them a more decorative finish, aluminium undergoes special finishing processes:

- ANODIZED: Bright silver (PB), Matt silver (PM), Bright gold (OB), Matt gold (OM), Brushed silver (PC), Matt bronze (BRM) and Matt black (NM).
- LACQUERED: White (BL), Cream (CR) and Light grey (GC).
- CHROME (CRO).

Although the aluminium profiles can be easily cleaned with any common cleaning product, it is not advisable to use steel wool, acid or abrasive cleaners (hydrochloric acid, bleach, etc.), because they can deteriorate or scratch the profiles.

To ensure a perfect preservation of the decorative finish that characterizes this material, it is essential to clean the profiles immediately after applying them, as well as to remove any cement or other remainders of materials used for the attachment of the profile.

Aluminium can be recycled 100% without diminishing its qualities.

ALUMINIUM. (A)

L'aluminium possède une combinaison de propriétés qui le rendent très utile dans le secteur de la construction, comme sa haute résistance à la corrosion, sa légèreté et sa souplesse. L'aluminium naturel en lui-même, au contact avec l'air forme rapidement une fine couche superficielle d'oxyde d'aluminium imperméable et adhérent, qui arrête le processus d'oxydation, voilà pourquoi c'est un matériel qui est résistant à la corrosion et qui dure longtemps. Cependant afin d'augmenter ces effets et de donner une finition plus décorative, l'Aluminium est soumis à des processus de finitions spéciales:

- ANODISÉ: Bright silver (PB), Matt silver (PM), Bright gold (OB), Matt gold (OM), Brushed silver (PC), Matt bronze (BRM) and Matt black (NM).
- LAQUE: White (BL), Cream (CR) and Light grey (GC).
- CHROME (CRO)

Les profilés en aluminium se nettoient facilement avec un produit habituel de nettoyage, cependant nous vous recommandons de ne pas utiliser d'éponge en acier, des produits acides ou corrosifs (eau de javel, ...) car ceux-ci pourraient détériorer ou rayer les profilés.

Afin de conserver parfaitement la finition décorative qui caractérise ce matériel, il faut nettoyer les profilés immédiatement après leur placement, en éliminant les restes de ciment ou d'autre matériel utilisé pour fixer le profilé.

L'Aluminium est un matériel 100% recyclable dont les qualités ne sont pas diminuées.

ALUMINIUM. (A)

Die Eigenschaften wie der hohe Rostwiderstand, die Leichtigkeit und Biegsamkeit dieses Metalls machen es sehr nützlich für das Bauwesen. In Verbindung mit Luft formt Rohaluminium selbst eine feine, wasserundurchlässige und griffige Oxidschicht, die den Rostvorgang aufhält und das Aluminium rostfrei und länger haltbar machen. Damit diese Wirkungen gesteigert werden und die Aluminium-Teile noch dekorativer sind, wird das Aluminium trotzdem mit speziellen:

- Eloxal-Verfahren: Bright silver (PB), Matt silver (PM), Bright gold (OB), Matt gold (OM), Brushed silver (PC), Matt bronze (BRM) and Matt black (NM).
- Lackierungen bearbeitet: White (BL), Cream (CR) and Light grey (GC).
- Chromé (CRO)

Obwohl Profil aus Aluminium leicht mit herkömmlichen Reinigungsmitteln gesäubert werden können, empfehlen wir, Stahlwolle oder säurehaltige Reiniger oder Scheuermittel (z.B. Salzsäure, Laugen, ...) zu vermeiden, denn sie könnten die Oberfläche beschädigen oder zerkratzen.

Um die dekorative Verarbeitung dieses Materials perfekt zu erhalten ist es unverzichtbar, die Profil sofort nach dem Einbau zu reinigen und dabei alle Reste von Zement oder anderen Baustoffen zur Befestigung der Leisten zu entfernen. Nicht zuletzt ist hinzuzufügen, dass Aluminium hundertprozentig wiederverwendet werden kann und dies der Qualität des Materials keinen Abbruch tut.

ACERO INOXIDABLE (S) - AISI 304

Los perfiles de acero inoxidable están fabricados en acero AISI-304. Su resistencia a la corrosión, sus propiedades higiénicas y estéticas hacen del acero inoxidable un material muy atractivo para satisfacer diversos tipos de demandas, como lo son las nuevas tendencias de diseño en la construcción y decoración de interiores.

Para la limpieza de los perfiles de acero inoxidable se usan productos comunes de limpieza, evitando siempre estropajos, limpiadores ácidos ó abrasivos (lejía, sulfumán, etc.), pues podrían rayar ó deteriorar el acabado estético de los perfiles. Así mismo para mantener la homogeneidad de la superficie de los perfiles, se recomienda secar los restos de agua para evitar que queden las marcas en los mismos, especialmente en los acabados con efecto espejo.

Los perfiles de Acero Inoxidable se suministran con un film protector transparente, el cual se ha de retirar tras la colocación para evitar ralladuras en las superficies vistas del perfil. En el caso de que durante la colocación quedase sobre el perfil algún resto de cemento u otro material, retirarlo inmediatamente y limpiarlo con materiales suaves que no puedan rayar la superficie del perfil, especialmente en el acabado con efecto espejo.

El Acero Inoxidable es 100% reciclable.

STAINLESS STEEL (S) - AISI 304

The stainless steel profiles are produced in AISI-304 steel. Its resistance to corrosion, its hygienic and aesthetical properties make it very suitable to meet different kinds of demands, such as the new design trends in the building industry design and indoor decoration.

To clean the stainless steel profiles, common cleaning products can be used, except for scouring pads, acid or abrasive cleaners (bleach, hydrochloric acid, etc.), because they could scratch or damage the aesthetic finish of the profiles. Also, to preserve the homogeneity of the profiles' surface, it is advisable to dry the water remainders to avoid stains on them, especially on the finishing with a mirror effect.

The stainless steel profiles are shipped with a transparent protection film, which has to be removed after applying so as to avoid scratches on the profiles' surfaces. If during the placement any remainders of cement or another material should stay on the profile, remove them immediately and clean them with soft substances that do not harm the profile's surface, especially on the finish with a mirror effect.

Stainless steel can be recycled 100%.

ACIER INOXYDABLE (S) - AISI 304

Les profilés en acier inoxydable sont fabriqués en acier AISI-304. L'acier est un matériel attrayant car il résiste à la corrosion et possède des propriétés d'hygiène et d'esthétique qui lui permettent de répondre à divers types de demande comme les nouvelles tendances modernes dans la construction et la décoration des intérieurs.

Pour les nettoyer il faut utiliser des produits ménagers habituels, en évitant les éponges, les produits ménagers acides ou abrasifs (eau de javel...) car ils pouvaient rayé ou abîmer leur finition. Par ailleurs afin de maintenir l'homogénéité de la surface de ces profilés, il est recommandé de sécher les restes d'eau afin d'éviter des marques, surtout sur les finitions ayant un effet en miroir.

Les profilés en Acier Inoxydable sont fournis avec une couche fine transparente de protection, qu'il faut enlever après leur installation afin d'éviter des râpures sur les surfaces vues du profilé. Si lors de l'installation du profilé il reste des petits morceaux de ciment ou d'un autre matériel, il faut le retirer immédiatement et le laver avec des produits doux pour ne pas rayer la surface du profilé, surtout celui ayant une finition en miroir.

L'Acier Inoxydable se recycle à 100%

EDELSTAHL (S) - AISI 304

Edelstahlprofil werden aus AISI 304 Stahl hergestellt. Durch Eigenschaften wie zum Beispiel Rostwiderstand, Hygiene und Ästhetik ist Edelstahl ein sehr angebrachtes Material, das verschiedenen Ansprüchen im Design der Gebäude und Inneneinrichtungen gerecht wird.

Zum Säubern unserer Profil bedarf es herkömmlicher Reinigungsmittel, außer Scheuerschwämmen, säurehaltigen oder scheuernden Reinigern wie Laugen oder Salzsäuren, da sie die Profil zerkratzen oder das Aussehen anders beschädigen könnten. Um die Gleichmäßigkeit der Oberfläche bei Profil zu gewährleisten, insbesondere solche mit Spiegeleffekt, empfehlen wir die Wasserreste zu entfernen, damit keine Flecken sichtbar bleiben.

Die Edelstahlprofil werden mit einem unsichtbaren Schutzfilm geliefert. Man sollte ihn nach dem Anbringen entfernen, damit keine Kratzer auf der Oberfläche entstehen. Falls beim Einsetzen Reste von Zement oder anderen Materialien auf der Oberfläche bleiben sollten, entfernen Sie diese sofort und säubern Sie sie mit milden Reinigern, die nicht scheuern und die vor allem dem Spiegeleffekt nicht schaden.

Edelstahl kann zu hundert Prozent wiederverwendet werden.

LATON (L): El latón es una aleación de cobre y zinc que posee una combinación de propiedades muy interesantes para el sector de la construcción, tales como su alta resistencia a la corrosión y a las condiciones salinas, su ductilidad y sobre todo su elegante color dorado.

Se presentan dos tipos de perfiles:

- Latón natural, que garantiza que su uso en pavimentos no afectará a su aspecto, pues puede ser pulido a la vez que el suelo.

- Latón cromado, el baño de cromo proporciona un acabado más decorativo y mucho más brillante al perfil. No utilizable en pavimentos.

Los perfiles de latón se limpian fácilmente con cualquier producto habitual de limpieza, no obstante se recomienda no usar lana de acero, limpiadores ácidos o abrasivos (sulfumán, lejía, etc), pues podrían deteriorar o rayar los perfiles.

Para conservar, es indispensable limpiar los perfiles inmediatamente después de su colocación, eliminando cualquier resto de cemento o de otro material usado para la fijación del perfil.

El Latón es un material 100% reciclable sin merma de sus cualidades

BRASS (L): Brass is a copper and zinc alloy which has a combination of very interesting properties for the construction sector such as its high resistance to corrosion and the saline conditions, its ductility and, in particular, all its elegant golden colour.

There are two types of profiles:

- Natural brass which ensures that its use in flooring will not affect its appearance, as it can be polished at the same time as the floor.

- Chrome-plated brass, the chrome bath affords a more decorative finish and the profile is much shinier. Not usable on floorings.

Although the brass profiles can be easily cleaned with any common cleaning product, it is not advisable to use steel wool, acid or abrasive cleaners (hydrochloric acid, bleach, etc.), because they can deteriorate or scratch the profiles.

To ensure a perfect preservation, it is essential to clean the profiles immediately after applying them, as well as to remove any cement or other remainders of materials used for the attachment of the profile.

Brass can be recycled 100% without diminishing its qualities.

LAITON (L): Le laiton es un alliage de cuivre et de zinc qui possède une combinaison de propriétés très intéressantes pour le secteur de la construction, ainsi sa résistance élevée à la corrosion et aux conditions salines, sa ductilité et surtout son élégante couleur dorée.

On présente deux types de profilé:

- Laiton naturel qui garantit que son utilisation sur pavement n'affectera pas son aspect, car il peut être poli en même temps le sol.

- Laiton chromé, le bain de chrome procure une finition plus décorative et beaucoup plus brillante au profilé. Non utilisable sur pavement.

Les profilés en laiton se nettoient facilement avec un produit habituel de nettoyage, cependant nous vous recommandons de ne pas utiliser d'éponge en acier, des produits acides ou corrosifs (eau de javel, ...) car ceux-ci pourraient détériorer ou rayer les profilés.

Afin de conserver parfaitement, il faut nettoyer les profilés immédiatement après leur placement, en éliminant les restes de ciment ou d'autre matériel utilisé pour fixer le profilé.

Le laiton est un matériel 100% recyclable dont les qualités ne sont pas diminuées.

Información técnica / Recomendaciones de colocación según materiales

Technique information / Placement recommendation by materials

	Interior/Indoor	Exterior/Outdoor	Pavimento/Floor	Revestimiento/Wall
Gama de color PVC / PVC range of colour	*			*
Gama decorados PVC / PVC decoration range	*			*
Gama Rusticos PVC+FN / Rustic range PVC+FN (R)	*		*	*
Gama Rusticos TEXTURA PVC+FN / TEXTURE Rustic range PVC+FN (R-TX)	*	*	*	*

Gama de ALUMINIO / Aluminium range (A)				
Aluminio Lacado / Powder coated aluminium				
Blanco (BL)	*	*		*
Crema (CR)	*	*		*
Aluminio Lacado Texturas / Texture Powder coated aluminium				
Arena camel (ARCA)	*	*		*
Arena gris claro (ARGC)	*	*		*
Arena gris (ARGR)	*	*		*
Arena marron (ARMA)	*	*		*
Arena oxido (AROX)	*	*		*
Arena antracita (ARAN)	*	*		*
Arena negro (ARNE)	*	*		*
Aluminio Anodizado / Anodized aluminium				
Plata brillo (PB)	*			*
Plata mate (PM)	*	*	*	*
Plata cepillado (PC)	*	*	*	*
Champagne brillo (CHB)	*			*
Champagne cepillado (CHC)	*	*	*	*
Oro rosa brillo (ORS)	*			*
Oro rosa cepillado (ORC)	*			*
Oro brillo (OB)	*			*
Oro mate (OM)	*		*	*
Bronce mate (BRM)	*		*	*
Negro mate (NM)	*			*
Negro brillo (NEB)	*			*
Aluminio Laminado / Laminated aluminium				
Blanco 2 (BL2)	*		*	*
Roble claro (RC)	*		*	*
Haya (HA)	*		*	*
Roble natural (RN)	*		*	*
Roble (RO)	*		*	*
Madera gris claro (MGC)	*		*	*
Madera gris (MG)	*		*	*
Cerezo (CE)	*		*	*
Sapelly (SA)	*		*	*
Nogal satinado (NS)	*		*	*
Nogal (NO)	*		*	*
Wenge (NEC)	*		*	*

ACERO INOXIDABLE AISI 304 / Stainless steel AISI 304 (S)				
Inox brillo (IB)	*	*	*	*
Inox cepillado (IC)	*	*	*	*
Negro brillo (NEB)	*	*		*
Negro cepillado (NEC)	*	*		*
Cobre brillo (COB)	*	*		*
Cobre cepillado (COC)	*	*		*
Oro brillo (OB)	*	*		*
Oro cepillado (OC)	*	*		*
Old bronze (OLBR)	*			*
Old cooper (OLCO)	*			*

LATON / Brass (L)				
Laton cromado (CRO)	*			*
Laton natural (NAT)	*	*	*	*
Antique broze (ABR)	*			*
Antique cooper (ACO)	*			*

MADERA NATURAL / Natural wood (N)				
Ayous	*			*
Iroko (N)	*	*	*	*



Perfiles Profiles



Desagües Drains



Autonivelante Self-levelling



Herramientas Tools



Mosaicos AD AD Mosaic



Pol. Ind. Can Sedó • Nave 1A
(08292) Esparreguera • Barcelona • Spain
Tel.: 00 34 93 777 50 72 / 59 50
www.euroshrink.es

